

Evaluation of the Field Performance of Residential Fuel Cells

Final Report

E. Torrero
*Cooperative Research Network
National Rural Electric Cooperative Association
Arlington, Virginia*

R. McClelland
*Energy Signature Associates Inc.
Pittsburgh, Pennsylvania*



NREL

National Renewable Energy Laboratory
1617 Cole Boulevard, Golden, Colorado 80401-3393
303-275-3000 • www.nrel.gov

Operated for the U.S. Department of Energy
Office of Energy Efficiency and Renewable Energy
by Midwest Research Institute • Battelle

Contract No. DE-AC36-99-GO10337

Evaluation of the Field Performance of Residential Fuel Cells

Final Report

E. Torrero
*Cooperative Research Network
National Rural Electric Cooperative Association
Arlington, Virginia*

R. McClelland
*Energy Signature Associates Inc.
Pittsburgh, Pennsylvania*

NREL Technical Monitor: Holly Thomas

Prepared under Subcontract No. AAD-1-30605-12



NREL

National Renewable Energy Laboratory
1617 Cole Boulevard, Golden, Colorado 80401-3393
303-275-3000 • www.nrel.gov

Operated for the U.S. Department of Energy
Office of Energy Efficiency and Renewable Energy
by Midwest Research Institute • Battelle

Contract No. DE-AC36-99-GO10337

NOTICE

This report was prepared as an account of work sponsored by an agency of the United States government. Neither the United States government nor any agency thereof, nor any of their employees, makes any warranty, express or implied, or assumes any legal liability or responsibility for the accuracy, completeness, or usefulness of any information, apparatus, product, or process disclosed, or represents that its use would not infringe privately owned rights. Reference herein to any specific commercial product, process, or service by trade name, trademark, manufacturer, or otherwise does not necessarily constitute or imply its endorsement, recommendation, or favoring by the United States government or any agency thereof. The views and opinions of authors expressed herein do not necessarily state or reflect those of the United States government or any agency thereof.

Available electronically at <http://www.osti.gov/bridge>

Available for a processing fee to U.S. Department of Energy and its contractors, in paper, from:

U.S. Department of Energy
Office of Scientific and Technical Information
P.O. Box 62
Oak Ridge, TN 37831-0062
phone: 865.576.8401
fax: 865.576.5728
email: <mailto:reports@adonis.osti.gov>

Available for sale to the public, in paper, from:

U.S. Department of Commerce
National Technical Information Service
5285 Port Royal Road
Springfield, VA 22161
phone: 800.553.6847
fax: 703.605.6900
email: orders@ntis.fedworld.gov
online ordering: <http://www.ntis.gov/ordering.htm>



List of Acronyms

AC	alternating current
CRN	Cooperative Research Network
CSA	Canadian Standards Association
DC	direct current
DG	distributed generation
DOE	Department of Energy
DPDT	double-pole, double-throw
EPRI	Electric Power Research Institute
G&T	generation and transmission
HHV	higher heating value
LHV	lower heating value
LPG	liquefied petroleum gas
NRECA	National Rural Electric Cooperative Association
NREL	National Renewable Energy Laboratory
PEM	proton exchange membrane
PSIA	pounds per square inch absolute pressure
RFC	residential fuel cell
SCF	standard cubic foot
TP	temperature and pressure
UPS	uninterruptible power supply

Executive Summary

Overview

Distributed generation (DG) has attracted significant interest from rural electric cooperatives and their customers. Cooperatives have a particular nexus because of inherently low customer density, growth patterns at the end of long lines, and an influx of customers and high-tech industries seeking to diversify out of urban environments. Fuel cells are considered a particularly interesting DG candidate for these cooperatives because of their power quality, efficiency, and environmental benefits.

The National Rural Electric Cooperative Association (NRECA) Cooperative Research Network (CRN) residential fuel cell (RFC) program demonstrates RFC power plants and assesses related technical and application issues. This final subcontract report is an assessment of the program's results. Significant effort has been expended to ensure the CRN RFC demonstration program is more than an engineering endeavor to assess the inner workings of fuel cell power plants and their grid interactions. The program has been tailored to look not only at grid interconnects in detail but also at related, equally crucial areas.

The structure of this 3-year CRN program leverages Department of Energy (DOE) and National Renewable Energy Laboratory (NREL) funding. The CRN RFC demonstration program effort is extensive and costs more than \$1 million for a 3-year effort when ancillary support efforts by CRN program affiliates are included. Because of substantial collaboration, the DOE-NREL portion is approximately \$100,000 for the first year and represents a small fraction of the overall CRN RFC program's implementation cost.

Key Information

The program's companion "Residential Fuel Cell Demonstration Handbook" (NREL/SR-560-32455) serves as a comprehensive guide to RFC technology and related issues. More than 150 pages cover topics such as fuel cell technology and demonstration planning. The handbook describes electrical installation and interconnects, including grid-parallel, grid-independent, and dual modes. Furthermore, key interconnect issues—such as 1547 islanding, flicker, and power quality—are examined.

In addition, a DG interconnection handbook has been developed by NRECA, the parent of CRN. Its goal is to move DG forward into general use. IEEE 1547 guidelines and their application are detailed. The handbook is more than a list of regulations. Developed for both co-op personnel and their customers, its 105 pages explain the intent of the regulations, why they are technically necessary, and implementation specifics.

A CRN demonstration tool kit has been developed for internal management and technical use within the program. This is used to maximize reporting accuracy and enhance analysis by the CRN program and individual participants. It also enables the most efficient use of resources by participants and program personnel so maximum effort can be spent on thoughtful analysis rather than data manipulation. Concurrently, an active users group provides a mechanism through which common issues, needs, and efforts can be addressed for the productivity and efficiency of all participants.

Electrical Interconnect and Dispatch

Criteria

RFC units can satisfy two purposes. The first is DG on the grid; the second is isolated operation at remote sites. Because of the first cost of alternative equipment and the potential to offset line extension costs of \$10,000 or more per mile of single-phase line, manufacturers increasingly see propane-fueled, edge-of-the-grid fuel cells as a premier early-entry market.

Both modes of operation are important to co-ops and their operating regions. For example, given reasonable reliability and cost, grid-independent operation can provide co-ops and their customers with an alternative to costly line extensions to serve distant, small loads. Conversely, grid-parallel units—particularly those with remote dispatch for daytime power output in excess of customer loads—can provide an added dispersed generation grid source while enhancing customer appeal if they can automatically disconnect from the grid and run in a grid-independent mode during a grid outage. Moreover, to the extent that at least some battery and charger capacity are already built in, it is conceptually possible in the future to have a smaller cell stack that uses both its output and the grid at night to charge batteries for full daytime operation. Thus, a remarkable potential also exists for RFCs to be concurrent, load-leveling, on-grid electric storage systems.

Initial Demonstration Results

A key subject of this report is the electrical interconnect grid of the Fort Jackson RFC. This site is part of the CRN RFC demonstration program. Its radial grid is similar to that of a typical co-op in that it is fed on one end by a single substation. The fuel cell installation is on a two-wire, single-phase circuit, with the interconnect point 2,100 ft from the substation. The radial extends 1,500 ft beyond the RFC.

This Plug Power unit is CSA-certified and, thus, meets 1547-type guidelines. It operates as a dual-mode critical load unit and has a dispatch setting from 2.5 kW to 5 kW when in grid-parallel mode. Because residential load profiles tend to be highly variable, there are nighttime periods when the fuel cell has successfully exported power into other dwellings on the secondary side of the transformer and even back into the grid.

Based on the fuel cell's certifications and favorable demonstration experience at other sites, no anti-export or redundant protective relaying were required at this site. During a grid outage, the unit properly disconnected from the grid and continued to supply critical loads in the dwelling in grid-independent operation. This is known as "dual-mode operation" and is an appealing, if not essential, customer feature for grid-parallel RFCs.

This site's favorable grid interconnect experience is consistent with that of more than 125 similar RFC units across the country. These Plug Power units, operating in 18 states, have already demonstrated more than 1.1 million hours of equally successful experience following proper grid-parallel interconnect procedures.

If an RFC produces a constant power level of 2.5–5 kW like the Fort Jackson unit, then some power is exported from the customer's dwelling at least part of the time. As noted earlier, there have been no interconnect issues or operation problems at the site. Nonetheless, the question of the optimum mode and output level of DG operation for the customer and for the grid remains.

Dispatch Economics

For DG to achieve its potential, RFCs need to interface with the grid in some manner.

Based on prospective market-entry RFC specifications, grid-parallel units are likely to have clock-controlled dispatch capability. However, the fuel cell and the grid will almost certainly have different cost profiles. In turn, the economics will feed back to prospective consumers and affect the amount of DG prospectively available for grid use. Given co-op interest in RFCs and grid-parallel DG, an analysis of potential dispatch outcomes is both needed and timely. This report's analysis builds composite load and dispatch curves and generates graphs of a customer's hourly load curve segments and fuel cell dispatch levels. Calculations then determine cost and capacity effects on the customer's use pattern and on the grid.

Manufacturers Catalog Distributed Generation Effect

RFC applications pose difficult challenges. The 4–10-kW fuel cell power plant is much smaller in capacity and higher in cost than what is required for commercial building or transportation applications, which are in the 50–200-kW range. However, instead of tens or hundreds of units a year, RFCs could ultimately have appliance-like production volumes. This is critically important to the success of RFC DG. Part of the users group effort has assessed dollars-per-pound costs for RFCs and comparable common products and how product price has changed for other products as sales volumes increased.

Equally important is an understanding of how customer uses interrelate with planned fuel cell capacities. Using DOE Energy Information Administration census questionnaires, 1,500 dwellings were analyzed for detailed consumption data from actual utility bills. The information was processed to show the number and size of users relative to average annual electric loads in kilowatts.

Of particular importance is the fact that the overall market distribution shows relatively small annual loads. The composite frequency distribution peaks at less than 1 kW. Moreover, 80% of the fuel cell applications have an average electric use less than 2.1 kW. In addition, many of these residences have electric water heating, considered a prime candidate for fuel cell thermal recovery. For example, some 30% of urban and suburban residences have electric water heaters, and electric water heater saturations reach 67% in rural areas. Thus, the actual fuel cell customer electric use profile will be smaller because the electric water heater portions of the load would invariably be converted to fuel cell thermal recovery. In fact, after making this application adjustment, 80% of the fuel cell-potential residences have an average electric use less than 1.6 kW.

The real user cost of an RFC is its actual installed cost and not merely its technology goal of so many dollars per kilowatt in manufacturing cost. To a customer, the technology manufacturing prices, widely followed as dollars per kilowatt, are indistinguishable from the installation costs to make it work. Installation costs and related barriers are being extensively worked as part of the CRN RFC demonstration program.

The manufacturer's "catalog" is a determinant of the success of RFC DG. This report illustrates the importance of manufacturer, industry, and research agency understanding of how economies of scale and production couple with market profiles in a complex development undertaking such as RFCs. Market modeling shows that manufacturer catalog selection alone can change the DG economic potential eight-fold.

Thermal Recovery

Importance

The significance of thermal recovery for RFCs transcends energy-efficiency improvements. Economically accomplished, thermal recovery provides energy cost savings offsets that are vital to paying for the fuel cell power plant and its fuel.

A thermal recovery of 10,000 Btu/hour is equivalent to the electric energy generated by a PEM cell stack running at 2.9 kW. If this level of fuel cell thermal energy were used to displace gas water heating at 65% efficiency, the effective savings would be 15,400 Btu/hour ($10,000 / 0.65$). This represents a savings of more than 40% of the power plant's fuel bill for that hour's operation. Thus, thermal recovery is more than just a way to enhance energy efficiency for public relations or environmental reasons.

Thermal recovery systems and their customer applications require an understanding of the application and a careful system design. Success also demands an attentive balance between the thermal recovery achievable and equipment and installation costs. Developing this balance and user understanding are the reasons for creating the detailed RFC installation cost-estimating program contained in the CRN RFC demonstration tool kit.

Hot Water Heating

Hot water heating is a year-round load that operates in the “right” temperature range for RFC thermal recovery and, moreover, comes with built-in site storage. If the 10,000 Btu of fuel cell thermal recovery can be used, 15 gal of hot water an hour could be heated (compared with a typical residential use of 80 gal a day). Moreover, this use principally occurs during the day, when the fuel cell is likely to be producing at a higher output to support dwelling electric loads or provide larger dispatch to the grid.

Thermal recovery to offset electric water heating can be particularly economic in grid-connected DG scenarios. First, it improves the fuel cell economics and might offset some of the propane cost. Second, the absence of the 4.5-kW load per element in the electric water heater removes a like generating demand from the grid while increasing the fuel cell’s ability to meet the dwelling’s other loads, particularly if an electric heat pump is part of that customer’s energy portfolio.

System examples include the Rheem Solaraide hot water heater preheat configuration developed within this effort and installed at one Department of Defense site. Also installed is the Bradford White internal coil thermal recovery water heater, and being reviewed are two solar units: a Wand that inserts into the outlet of an existing water heater and a Heliodyne external U-shaped heat exchanger with two circulating pumps. In addition, direct thermal recovery systems that use the customer’s own potable water heater in the fuel cell thermal recovery circuit have been reviewed, and the installation costs have been estimated.

Space Heating

Space heating shows promise if application issues can be overcome. The first is that 10,000 Btu is small compared with the likely furnace output, and a furnace operation of 800–1,700 hours represents only 9%–19% of the year. The second concern is that the 140°F thermal recovery temperature is low compared with the 180°F typically used for hydronic (water filled) commercial building heat exchangers or residential baseboard units.

Space heating thermal recovery has one and a half to three times the potential thermal use of water heating. Although space heating is not normally considered for fuel cell thermal recovery, when carefully combined with pre-existing water heating thermal recovery, the incremental cost of residential space heating may be attractive. The system starts as a “standard” indirect thermal recovery system for an existing gas or electric water heater. This system then extends to include a hydronic coil in the heating system ductwork and two three-way bypass valves using a special control algorithm.

Calculating the thermal recovery savings from space heating is a complex undertaking because hot water thermal recovery and space heating thermal recovery operate in series. Thus, the energy available for space heating thermal recovery is the balance from the thermal recovery input after hot water heating is deducted. Also, the hours that space heating thermal recovery can be used each year is a function of local climatic conditions and a residence’s thermal demand at specific outdoor temperatures. Moreover, fuel savings are a function of the type of heating fuel and the system using that fuel.

As a result, software was developed to calculate space heating annual cost savings. This computation has built-in data for heating systems and fuels. Daily average water heating thermal recovery is calculated and then subtracted from the fuel cell's available thermal recovery to yield the energy available for space heating. Although specific data can be entered, users can also toggle input to select climatic temperature bin data for Atlanta, Georgia, or Columbus, Ohio. These locations are often used for benchmark analysis in the heating, ventilation, and air conditioning industry.

For thermal recovery, two elements are crucial. Thermal recovery attractiveness is essentially the fuel value of energy savings offsets compared with the cost of installing the thermal recovery systems. The first part of the effort is to intensively evaluate hot water thermal recovery systems and the potential for space heating fuel offsets. The second part is to reduce the general costs of installed thermal recovery systems. Coordinated efforts are under way within the CRN RFC demonstration program to enhance the potential for fuel cell thermal recovery at residential dwellings and reduce the installed costs of the systems. Significant progress is being made on both fronts.

Natural Gas and Propane Fuel

Fuel supply interconnection and metering for the RFC demonstration sites has been straightforward, with no significant issues evident from the field demonstrations. The standard installation guideline includes a meter pulse output for data logging, a pressure gauge, and a fuel sampling port.

Knowing the higher and lower heating values (HHV Btu/SCF and LHV Btu/SCF) with reasonable accuracy is essential for measuring the efficiency of RFCs in field demonstrations. Energy output can be readily measured by a conventional electric meter. However, the energy input is more complex and is subject to significant error, particularly for propane/liquefied petroleum gas. For this reason, guidelines have been developed as part of the CRN RFC demonstration tool kit.

Another consideration is that sulfur compounds can irreversibly poison the platinum catalyst inside PEM fuel cell stacks and harm the catalysts in the front-end fuel processor beds. Solid oxide units are somewhat less sensitive to sulfur compounds in the fuels but will also be affected. An added concern, particularly with propane, is that variable sulfur-bearing odorant levels can prematurely saturate the fuel cell's front-end sulfur removal cylinders and cause irreversible damage.

Market and Grid Effects

Edge of the Grid

Of particular early interest in assessing grid DG potential is the profile of larger customers to which an RFC is economically attractive. Valuable DG grid interconnect data have been mined from DOE's Energy Information Administration residential energy census. These are coupled with CRN LoadShape software to develop estimates for grid coincident hourly residential uses, demands, and market frequency distributions.

As part of the CRN RFC demonstration program, co-ops were surveyed to determine the potential for RFC DG as an alternative or supplement to serving particularly isolated sections of their service areas. Serving such customers is not inexpensive. Co-ops typically have 22 poles per mile, even for a single-phase distribution or customer service line. Single-phase distribution lines typically cost at least \$10,000/mile. The cost depends on soil conditions for setting poles and right-of-way accessibility and clearing costs. Moreover, in some areas of the country, securing rights of way is difficult because of federal regulations and even other customers.

More than 5% of homes on many co-op lines have service or distribution lines more than 1 mile long. Indeed, this percentage may be much higher for co-ops serving particularly remote regions. At \$10,000/mile for a single-phase distribution service extension, a 2-mile service line extension would cost the customer \$18,600. Conversely, this could be used to offset much, if not all, of the purchase and installation costs of even an early-market RFC. This is one factor of co-op and customer interest in RFCs.

Other factors are electric needs beyond the end of the grid, such as irrigation and communication facilities, and the construction of residences beyond the economic reach of the grid. Actual remote residence data are difficult to come by because records are not required and no census questions explore this issue. Even so, co-ops typically have around 10,000 customers, and most in the Southeast report at least a few off-grid residences in their service territories. In the Mountain states, the estimate is 2 or 3 remote residences per 1,000 customers. Although not covered in this report, the survey also explored what systems these customers use to provide their power.

Moreover, a corollary issue merits exploration. This is whether the existence of an attractive RFC option might encourage off-grid remote residence construction by individual owners or builders. For example, given the rise of cell phone and satellite technology, an attractive fuel cell option that replicates an on-grid electric lifestyle could open up a number of attractive home sites in the South and West that have been so far bypassed by customers and builders because of high extension costs or right-of-way permitting difficulties.

Comparison With Alternate Technologies

With the exception of the engine generator, the principal technologies for remote off-grid residential power applications have been solar photovoltaics or wind generation. To understand how RFCs might fit into the picture, the CRN RFC demonstration program conducted an assessment of the costs, strengths, and weaknesses of remote residence options for review by the users group. This report summarizes these results in terms of initial capital costs for equipment and installation and for annual ownership and operation.

Remote residences are an important early market for RFCs, but little data exist to quantify this target for existing or new construction. Also included in this category are other similar-size off-grid uses. New manufacturer offerings of propane-fueled demonstration power plants demonstrate accelerated manufacturer interest in off-grid applications.

Early-Entrance Market Importance

Early-entrance markets are a crucial bridge between initial entries of “commercial” RFCs and more mature, lower-priced units. Without a successful early-market entrance of RFCs at reasonable sales volumes there will be no future widespread DG from mature RFCs. Early-market entrance is demonstrably the shoal that has sunk more promising product ships than any other.

Separately early-entry markets may exist for outage-sensitive grid users such as home offices users and high-income residential users. Both are high-end users in regions subject to ice storm and hurricane grid failures, some of which can last for days or longer. There appear to be similarly sensitive users in the governmental and light commercial areas. Examples include radio dispatch and communications facilities and backup power for convenience store lighting and gasoline pumps. In all likelihood, other applications remain to be assessed.

Other potential early-entrance markets would serve high-income technophiles or upscale customers desiring a “green,” low emissions power source. However, relying on these groups to support significant sales is problematical without more information such as extensive surveys and focus groups. Focus groups have operated within the CRN DG program, but this is principally an effort requiring fuel cell manufacturers’ attention.

“Green” or upscale builders also represent a potential early-entrance market meriting consideration. These may represent subdivisions addressing customer concerns on electrical outage security or even microgrids in attractive but difficult-to-electrically-reach areas.

Critical Present Need for Market Model

Valuable market application information has been mined from extensive analysis using the CRN RFC market analysis program software. This software tool began as a means for co-ops to gain intuitive, graphic understandings of their potential fuel cell economic market and of how customer size, type of water heating, fuel prices, and electric rates affect that market. Input data are from DOE’s Energy Information Administration 1993 surveys of residential energy use and markets. The spreadsheet program incorporates the 1,732 samples for which detailed consumptions are available from actual utility bills.

This model has proved unusually flexible and can incorporate a catalog of prospective fuel cell power plants so that the model’s customers can “choose” the unit that best meets their load. It has been used for the major sensitivity study results in this report.

These results affirm a pressing need for a “good” industrywide market model to guide technology development and RFC application for DG planning. This report’s results only scratch the surface of the value that could have been achieved, and should have already existed, within the RFC development industry.

A “good” market model is fundamental to guiding the nation’s technology development goals and assessing if DG markets can or will exist. The last section of this report discusses the characteristics that should be embedded in such a residential DG market model for development under DOE.

To ensure universal applicability and acceptance, the market model protocol guidelines should be a joint effort of DOE and the DG industry. A special task force should guide the protocol effort so the end result is universally available. In addition to RFC technology and economic modules, strong consideration should be given to similar modules for solar photovoltaics, solar water heating, and wind.

The basic model should use databases for new and existing single-family homes and include individual energy profiles with heating system and appliance types. Annual electric use should also be part of the profile. Although a number of private data sources are available, a merged database of EIA surveys should be good enough, and a statistical base of perhaps 3,000–5,000 homes should be sufficient. Regional information about basic electric rates, fuel prices, and demographics and the ability to overlay specific rate schedules on selected regional data should be included.

Model technology cost comparisons should be made on a dwelling-by-dwelling basis and need to accommodate manufacturer price changes over time, installation costs by category, maintenance costs in cents per kilowatt-hour and as dollars per year, propane tank costs, optional dual-fuel additions for heat pumps, a manufacturer catalog of sizes, purchase costs, and part-load efficiency curves. Escalations should allow for adjustments of energy and other costs over time. Key variables such as total installation cost should be able to overlay a statistical probability distribution range of values for Monte Carlo simulations. The model should then use the equipment module to calculate residence-by-residence economic comparisons of the equipment and the dwelling's existing annual energy costs.

Insightful market penetration overlay calculations should incorporate adjustable penetration curves for new and existing construction. Such curves compute the percentage of persons who will use DG as a function of differential annual costs or savings at each dwelling. Included should be the flexibility for user-defined penetration models coupled with Monte Carlo statistical underlays. The latter should also include adjustments that are a function of key demographics such as owning versus renting and annual income. Market acceptance buildup curves should then project annual results and cumulative saturations by describing how the percentage using the technology changes as the product matures and consumer comfort levels increase. When possible, other product histories and data should be part of the model's user instruction package.

This DG acceptance model would be invaluable to the manufacturing component of the industry, agencies involved in technology development guidance, and end-user utilities needing prudent DG planning. It could likely be developed in 3–6 months at a relatively nominal cost compared with benefits of having such modeling capability for DG technology and application planning.

Full implementation of the model with solar and wind modules would greatly benefit all three DG technologies in development targeting, application analysis, and DG market penetration planning knowledge. To move this effort forward, a special limited-duration task force should be instituted from DG leaders, manufacturers, and model users to set needed modeling protocols and monitor the model's development and deployment within the DG arena. Development of this type of a powerful, user-friendly model would respond to needs already spelled out in DOE's Grid 2030 Vision and Roadmap.

Table of Contents

List of Figures	xvii
List of Tables	xviii
1 Demonstration Overview	1
1.1 Significant Co-Op Distributed Generation Incentive.....	1
1.2 Cooperative Research Network Demonstration Program Goals.....	2
1.3 Participation	3
1.4 RFC Technology.....	4
1.5 Funding and DOE Leveraging	12
2 Accomplishments	14
2.1 Demonstration Handbook	14
2.2 Co-Op Distributed Generation Interconnection Handbook	15
2.3 Cooperative Research Network Residential Fuel Cell Demonstration Tool Kit.....	15
2.4 Installation Cost-Estimating Tool Results	18
2.5 Cooperative Research Network Residential Fuel Cell Users Group	21
3 Electrical Interconnect.....	24
3.1 Application Configurations.....	24
3.2 Interconnect Configurations.....	25
3.3 Electric Grid Distribution Structure.....	28
3.4 Residential Fuel Cell Electrical Interconnect.....	35
3.5 Fuel Cell Grid Interconnect Experience.....	38
3.6 Dispatch Concepts.....	41
4 Thermal Recovery	51
4.1 Importance	51
4.2 Thermal Recovery Constraints.....	52
4.3 Water Heating	55
4.4 Water Heater Thermal Recovery Systems	59
4.5 Combination Space Heating and Water Heating Thermal Recovery.....	74
4.6 Thermal Recovery Heat Transfer Assessment.....	80
4.7 Thermal Recovery System Mapping.....	82
4.8 Reducing Thermal Recovery Costs.....	84
5 Natural Gas and Propane Fuel Supply	89
5.1 Standard Metering Installation.....	89
5.2 Lower Versus Higher Heating Value.....	91
5.3 Odorant Issues and Measurement	95

6	Market and Grid Effects	101
6.1	Residential Customer Application	101
6.2	End-of-the-Grid Applications	106
6.3	Overall Market Assessment	111
6.4	Need for Residential Distributed Generation Market Model.....	116

List of Figures

Figure 1.	Participants in the RFC demonstration program.....	3
Figure 2.	Residential fuel cell technology.....	4
Figure 3.	PEM fuel cell technology.....	5
Figure 4.	Solid oxide fuel cell technology.....	7
Figure 5.	Consumer product costs in dollars per pound.....	9
Figure 6.	Economies of scale and production.....	9
Figure 7.	CRN RFC market analysis.....	9
Figure 8.	Manufacturer RFC catalog selection effect.....	10
Figure 9.	Cooperative Research Network residential fuel cell demonstration funding.....	13
Figure 10.	CRN residential fuel cell program key accomplishments.....	14
Figure 11.	Monthly meter-reading tool (Fort Jackson data).....	17
Figure 12.	Installation cost-estimating spreadsheet program.....	20
Figure 13.	Fuel cell load application profile.....	24
Figure 14.	Residential fuel cell interconnect types and issues.....	26
Figure 15.	Typical co-op distribution system and fuel cell interconnect issues.....	30
Figure 16.	Residential grid configuration at Fort Jackson, South Carolina.....	34
Figure 17.	Residential fuel cell electrical interconnect and metering.....	36
Figure 18.	Alternate disconnect for RFC grid interconnect service.....	37
Figure 19.	200-kW fuel cell interconnect experience.....	40
Figure 20.	Co-op portion of survey results related to grid-parallel RFC applications.....	43
Figure 21.	RFC dispatch and export-import calculation program.....	46
Figure 22.	Grid dispatch modes, customer economics, and resulting export power.....	49
Figure 23.	Potable water direct thermal recovery system.....	60
Figure 24.	Indirect thermal recovery tank in front of existing water heater.....	66
Figure 25.	Replace existing water heater with indirect thermal recovery unit.....	68
Figure 26.	Additional thermal recovery systems under assessment.....	73
Figure 27.	Combination space heating and water heating thermal recovery.....	76
Figure 28.	Heat transfer from thermal recovery loop to water heater.....	81
Figure 29.	Thermal recovery mapping software and results.....	83
Figure 30.	Thermal recovery piping and circulating pump flow curves.....	85
Figure 31.	Commercially available thermal recovery controller.....	86
Figure 32.	Standard residential fuel cell fuel supply metering.....	89
Figure 33.	Potential propane odorant level changes over time.....	97
Figure 34.	RFC odorant and heating value sampling protocol.....	100
Figure 35.	Residential annual electric energy use patterns.....	102
Figure 36.	Residential fuel cell customer size profiles.....	103
Figure 37.	Rural co-op line profiles and remote market estimates.....	106
Figure 38.	Comparative cost of off-grid technologies.....	108
Figure 39.	Key residential fuel cell market analysis results.....	112
Figure 40.	Residential fuel cell early-entrance markets.....	115
Figure 41.	Residential distributed generation market model.....	117

List of Tables

Table 1. Installation Costs for Residential Fuel Cells in the Cooperative Research Network Demonstration Program.....	19
Table 2. Typical Residence Thermal Needs	54
Table 3. Typical Residential Hot Water Use and Electric Water Heater Profile.....	56
Table 4. Comparative Options for Electric Water Heating Residences When a Residential Fuel Cell Is Added.....	57
Table 5. Allowable Thermal Recovery Capital Costs to Offset Related Expenditures	58
Table 6. Actual Hot Water Draw for Typical Residential Uses.....	64
Table 7. Space Heating Thermal Recovery Savings and Allowable Capital Costs	78
Table 8. Comparative Hot Water Thermal Recovery Systems	82
Table 9. Residential Peak Demand Electric Relationships	105

1 Demonstration Overview

1.1 Significant Co-Op Distributed Generation Incentive

Distributed generation (DG) has attracted significant interest from cooperatives and their customers. Cooperatives have an interest because of their inherently low customer densities, growth patterns at the ends of long lines, and influx of customers and high-tech industries seeking to diversify out of urban environments. Fuel cells are considered a particularly interesting DG candidate because of their power quality, efficiency, and environmental benefits.

For the most part, cooperatives serve less-populated rural and agricultural areas, which represent some of the country's least-developed and roughest terrain. Even so, cooperatives sell about 10% of the nation's power to 15 million customers in 47 states and own almost half the distribution line miles in the country. To deliver power to their customer-owners, cooperatives average six customers per mile. This is significantly less than the rest of the electric utility industry's average of more than 30 customers per mile.

Added complications are that much rural electric growth occurs at the end of long feeder lines and societal trends are creating demands for enhanced power supply and distribution. One driver of these complications is the diversification from urban to rural environments by high-tech industries, data processing centers, and telephone order centers. Corollary trends are the growth of the "electronic home office" as well as the siting of residences in remote, difficult-to-serve areas.

Costly transmission and distribution rights-of-way must be acquired to upgrade or provide new lines for increased power supply to these locations via conventional central grid service. For example, single-phase distribution laterals cost about \$14,000 a mile, and a single- to three-phase conversion can cost as much as \$40,000 a mile.

Nearly one-half of electric cooperative power is provided by 60 generation and transmission (G&T) cooperatives. These G&T cooperatives are owned by their distribution cooperative members. Cooperatives anticipate the need for additional sources of power supply in the near future because of the growth trends described above and because urban development continues to spread into once-rural cooperative service areas. Distributing generation resources, such as microturbines or fuel cells, throughout a system may result in reduced transmission and distribution costs. Capital expenditures for distribution system equipment can be deferred, and costs for upgrading or reconditioning power lines can be minimized. In the long term, residential fuel cells (RFCs) and battery storage systems may operate not only as DG grid support but also as load levelers by recharging their battery pack at night from the grid. The battery pack in either instance would discharge during the day to support grid and residence peak loads.

In addition to the benefits of DG, applications such as RFCs and microturbines can offer strategic business opportunities such as equipment sales and ownership, joint ventures with customers or others to own and operate such systems, or maintenance and operation services. Indeed, because of their location and customer nexus, cooperatives and their G&Ts are particularly well-positioned to consider such endeavors should opportunities prove attractive.

The NRECA Cooperative Research Network (CRN) RFC program is designed to demonstrate RFC power plants from key manufacturers and assess related technical and application issues.

1.2 Cooperative Research Network Demonstration Program Goals

Key manufacturers are developing fuel cells for residential customer use and, therefore, as valuable grid DG supplements. Thus, this demonstration program has multiple goals:

1. To ascertain the performance, durability, reliability, and maintainability of RFCs
2. To identify issues associated with the interaction of the units with the grid and related dispatch
3. To assess the suitability of key materials, designs, and components for utility and customer performance
4. To assess and define interface requirements for fuel, electrical, thermal recovery, and water and to reduce related installation costs
5. To identify and define promising applications for such equipment, including needed planning for early-entry and mature markets.

This report is the first assessment of a joint project with the Department of Energy (DOE) and the National Renewable Energy Laboratory (NREL). It assesses the program's results and goals, with particular care paid to emerging issues and needs. Significant effort has been expended to structure the CRN RFC demonstration program as more than an engineering endeavor to assess the inner workings of fuel cell power plants and their grid interactions. The program has been tailored to look not only at grid interconnects but also into related yet equally crucial areas.

In this report, interface costs and experience merge with application assessments to form the first meaningful effort to assess actual installation costs of these distributed technologies. Installation costs are as important as the fuel cell purchase price and technology goals in cost per kilowatt. Installation costs can equal or exceed the cost of the RFC itself and, thus, are as critical to future success as low-cost, reasonably efficient RFC power plants. The third crucial element for the success of RFCs is a sound understanding of market size and purchase and acceptance decisions.

The profile of how and when the RFC unit produces power and thermal energy relative to customer needs is a key DG planning adjunct. This is because any power surplus results in dispatch to the grid, and any shortfall draws power from the grid. Likewise, only when thermal energy is reasonably used can any meaningful credit be created to offset the RFC’s electric power generation fuel cost. Principally through a CRN RFC users group, efforts are under way to better understand these types of issues and the planning associated with early-entrance and mature RFC markets.

1.3 Participation

Figure 1 identifies participants in the CRN RFC demonstration program. As the map illustrates, the CRN RFC demonstration draws from a spectrum of participants. These range from individual co-ops to large, multi-state G&Ts owned by co-op groups. Also included are Department of Defense (DOD) military base sites under the U.S. Army Corps of Engineers Construction Engineering Research Lab.

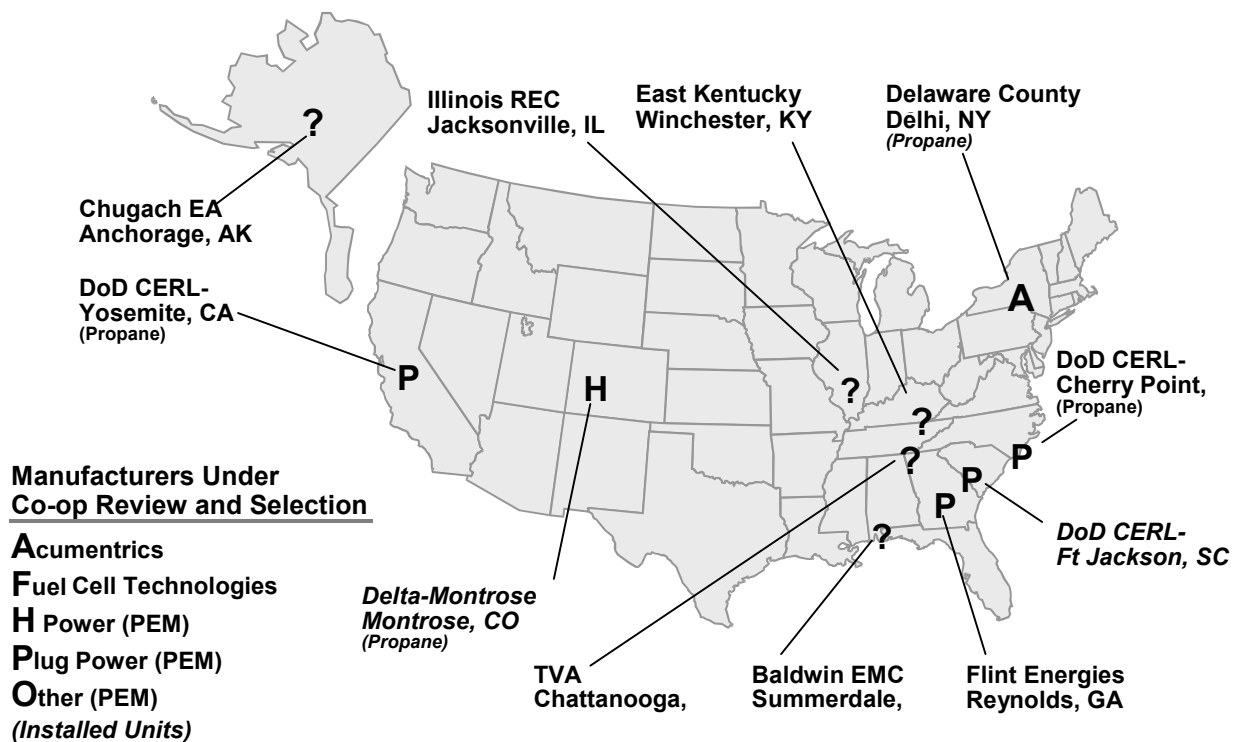

Figure 1. Participants in the RFC demonstration program

Adding multiple DOD sites significantly improves the breadth of the program and materially benefits all participants. For the program, valuable data and experience are added, further leveraging DOE funding. In return, DOD gains access to information about CRN demonstration installation and reporting guidelines, including special installation cost-estimating software that helps in installation and budgeting review and planning.

Although manufacturers were initially slow to release RFCs for demonstration purposes, the situation is changing. A co-op unit at the Delta-Montrose Electric Association in Colorado and a natural gas Plug Power fuel cell at Fort Jackson in South Carolina are already installed. These have provided valuable program validation and equipment data. A Plug Power unit is also operating at Flint Energies in Georgia.

Because of their awareness that co-ops represent a key remote and early-entrance market, manufacturers are placing increased emphasis on propane-fueled RFCs. Two propane Plug Power units are soon expected to be online under the CRN RFC demonstration umbrella. These are DOD units at Yosemite, California, and Cherry Point, North Carolina. The bulk of the remaining units in the CRN program are anticipated to be online and contributing valuable installation, commissioning, and operating data within the next 12 months.

This program's broad geographic distribution provides a wide range of climates and installation code jurisdictions. In addition, both natural gas- and propane-fueled units are being demonstrated. The latter are particularly useful because both end-of-the-line and remote DG applications are more likely to be propane-fueled; thus, this is an important component of application and market issue assessments. Consequently, the broad range of manufacturers and participants provides a sound, highly useful diversity within the program.

No permitting or code issues have been experienced at installed sites or other installations. Moreover, electrical interconnect issues have not been experienced during installation or operation at these sites.

1.4 RFC Technology

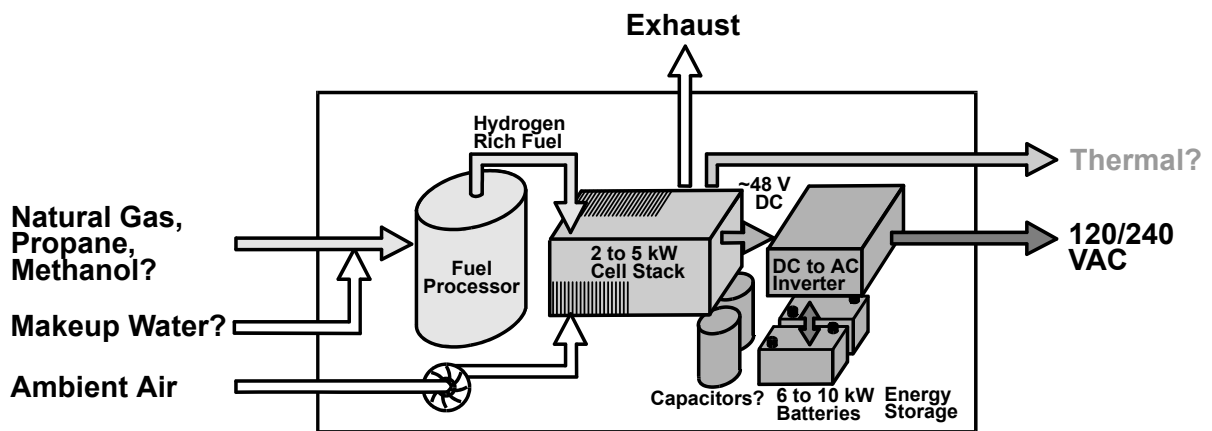

Figure 2. Residential fuel cell technology

RFCs produce power through an electrochemical reaction that produces direct current (DC) electricity, typically from hydrogen and oxygen from ambient air. Because the fuels are typically natural gas (CH₄) or propane (C₃H₈), a necessary step is to break the fuel molecule apart in a steam reforming operation. The end product of this reaction is a processed fuel that contains hydrogen and carbon monoxide. The DC power from the cell stack is then converted into alternating current (AC) power by an inverter that chops and switches the DC input into a reasonable approximation of a normal grid 60-cycle sine wave. Special software manages the system and determines when it is safe to connect the fuel cell with the local grid and the customer's load.

Typical homes use around 0.5–2 kW of electric power but can reach peak demands of more than 5–8 kW. This metered demand depends on the electric use in the home and the length, usually 15 min, over which the use is averaged.

Fuel cells are typically categorized by the type of electrolyte film or plate that hosts the electrochemical reaction in the cell stack and separates the air and fuel sides of the stack's cells. All electrolyte types have several common properties.

- They must be electrical insulators.
- They must be impervious to gases, including hydrogen and oxygen.
- They must be able to transport the ion of the fuel (H⁺) from left to right or oxygen in air (O⁻) from right to left across the electrolyte layer.

1.4.1 Proton Exchange Membrane Fuel Cells

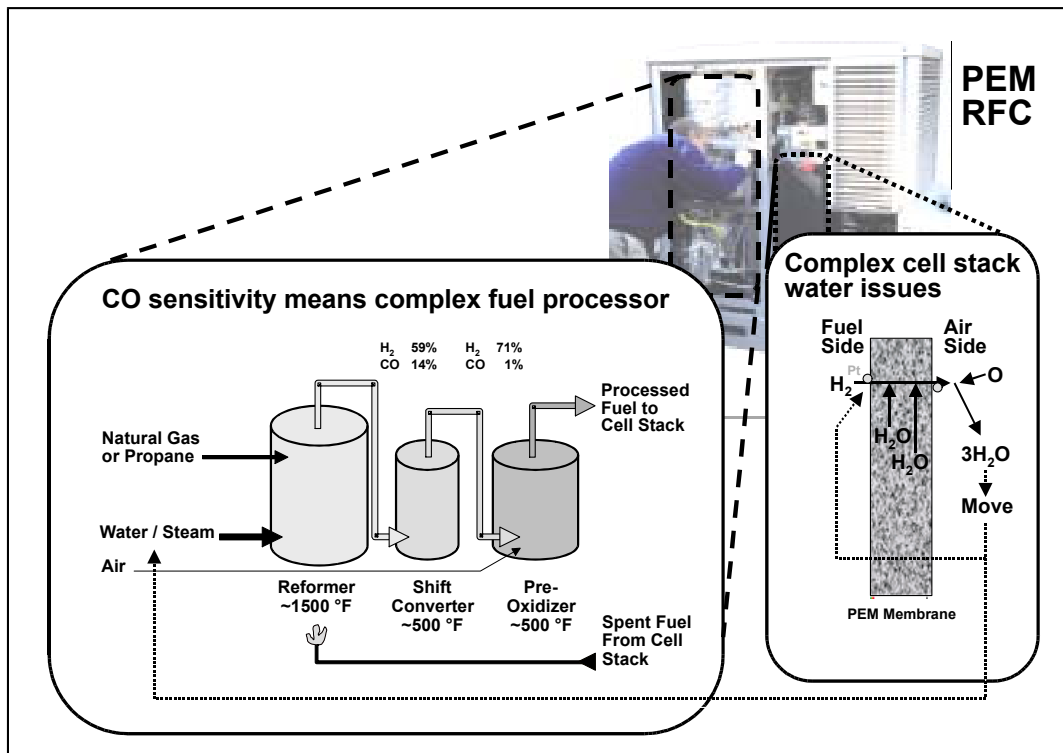

Figure 3. PEM fuel cell technology

When the CRN RFC demonstration program was initiated, the only RFCs available were proton exchange membrane (PEM) units. A PEM is a thin “plastic film” that operates at around 170°F. Plug Power is the market leader of the technology, at least as far as PEM RFCs are concerned. It recently acquired H Power, which also produced a limited number of PEM demonstration units.

Although the photo in Figure 3 shows a Plug Power RFC, the unit is typical of all PEM residential units. In this example, the fuel processor section is on the left, and the cell stack that uses the processed fuel is on the right.

As the right insert indicates, the hydrogen portion of the fuel is converted into a hydrogen ion that passes through the PEM to combine with oxygen supplied by an ambient air blower. Because the reactions would normally be too slow to be of practical use, a platinum catalyst is used on both sides of the PEM to speed them up. However, this creates several concerns. The first is that any carbon monoxide (CO) in the processed fuel deactivates the platinum catalyst. The second is that the cell stack’s byproduct is liquid water, and the PEM electrolyte film has water imbedded in it. The PEM is actually a Teflon-like material with sulfonic acid molecules that have internally attached water molecules. The hydrogen ions use these internal water molecules to travel through the membrane. This tends to dry out the membrane, which will crack if not kept moist. This means water control is an important design consideration. Air-side byproduct water must be continuously recycled back to “humidify” the fuel side of the PEM. Water, in the form of steam, is also needed by the fuel processor.

Low-temperature fuel cells such as PEM units need hydrogen as a fuel for the cell stack. This must be “manufactured” from fuel such as natural gas or propane. In the case of the former, the desired reaction is $\text{CH}_4 + \text{H}_2\text{O} \rightarrow 3\text{H}_2 + \text{CO}_2$. However, as shown in the insert, the initial reforming operation, running at 1,500°F to process fuel in a reasonably sized catalytic bed, produces 14% CO. A secondary step at a lower temperature gets this down to about 1%. Then, to get to the 0.01% concentration of CO demanded by the cell stack, air is introduced in yet a third catalytic bed to selectively “burn” most of the residual CO to CO_2 . These multiple fuel-processing steps, along with the heat exchange that the beds require to yield efficient fuel processing, lead to a relatively complex and expensive fuel processor for PEM RFCs.

1.4.2 Solid Oxide Fuel Cells

Until quite recently, solid oxide fuel cells were principally laboratory units. However, two companies are building solid oxide RFC demonstration units. The Acumentrics unit, shown in Figure 4, like all solid oxide fuel cells has no real need for an expensive, complex fuel processor. This is because, at an operating temperature of 1,400°F inside a cell stack “insulated oven,” the unit can process the fuel directly. In this case, the cell stack is composed of hollow tubes, with the fuel on the inside and air on the outside.

As shown in the insert, the fuel combines with byproduct steam from the cell stack reaction to produce H₂ and CO directly on the fuel interior of the stack tubes. In this case, oxygen ions pass from outside to inside the tube, where they combine with fuel to produce CO₂ and H₂O. The H₂O byproduct then synergistically makes more fuel react inside the tube.

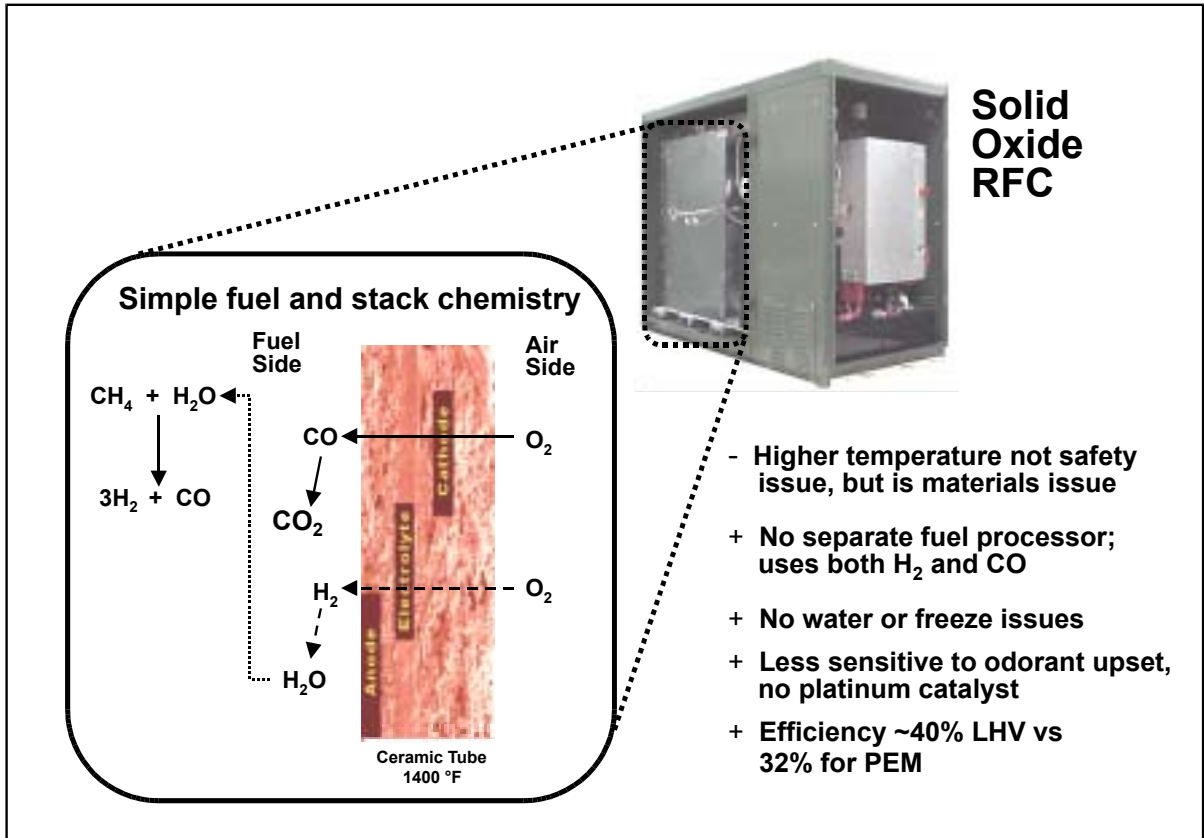

Figure 4. Solid oxide fuel cell technology

The resulting solid oxide RFC has no fuel processor and, because it runs above the boiling point of water, has no liquid water management, freezing issues, or makeup water line to install. It also needs no platinum catalyst, and because it “burns” CO to electrochemically produce electricity, it is not sensitive to CO poisoning. Thus, the solid oxide fuel cell has the potential to be less expensive than the more complex PEM RFC. Its potentially higher thermal recovery source temperature may also present an advantage.

However, the major advantage is that the solid oxide unit promises to be more efficient, principally because the inefficiencies of the separate, multiple-bed fuel processor are eliminated. For example, the fuel-to-electric conversion efficiency of a solid oxide RFC should be about 40% LHV (lower heating value) compared with around 32% for a PEM unit. Co-ops have a particular interest in this attribute because they serve areas in which homes have only about a 25% availability of natural gas and must use more expensive propane.

For example, natural gas might cost about \$7/million Btu HHV (higher heating value). In comparison, \$1/gal propane costs nearly \$11/million Btu HHV. When using propane, the efficiency difference between a PEM and a solid oxide unit is both real and significant. Compared with a PEM RFC, a solid oxide unit would save about \$450 annually for a 2-kW user, or about \$0.025/kWhr. A 5-kW load using a solid oxide unit versus a PEM fuel cell on propane would save \$1,100 annually, which at a typical capital recovery factor is equivalent to almost a \$9,000 power plant price reduction. Because of the potential for savings in DG costs for co-op customers, the CRN RFC demonstration program is diligently exploring the addition of solid oxide units, as shown in Figure 1.

1.4.3 Manufacturer Catalog Criticality

RFC applications pose difficult challenges. The needed 4–10-kW fuel cell power plant is smaller in capacity and higher in cost than what is required for commercial buildings or transportation applications (which use fuel cells in the 50–200-kW range). On the other hand, RFCs could ultimately have appliance-like production volumes.

A key function of the CRN demonstration program is to provide a forum for assessing and reviewing such issues. Figures 5–8 are taken from presentations within the CRN RFC users group. When combined with market assessments developed for the CRN RFC users group, such products reveal key fuel cell catalog issues that are particularly timely.

Figure 5 starts this analysis by exploring the costs of comparable mass-produced products using long-standing industrial engineering concepts. For example, given reasonable production volumes, all similar products tend to cluster around repeatable dollar-per-pound levels. One reason is that, given reasonable designs for consumer products, weight is a good indicator of the number of parts and resulting costs. For example, as illustrated in the chart, inverters cost around \$20 per pound. Most consumer products are in the \$5-per-pound range.

Products can have a somewhat broad but still relatively constrained range. As illustrated, a Pontiac automobile is around \$3/lb while a Lexus is around \$10. Dishwashers, heat pumps, and home generators all cluster around \$5/lb. More striking is that the exotic generation technologies—such as solar photovoltaics, residential wind generators, and microturbines—all cluster at around \$35/lb.

In contrast, the only commercial fuel cell product, the 200-kW phosphoric acid fuel cell, achieved pricing at \$20/lb, even at relatively small production volumes. If production volumes could have been tripled to around a hundred units a year, there is a high degree of confidence that Lexus-type pricing in the \$11/lb range could have been reached. This is a remarkable, yet unrecognized, fuel cell achievement.

These types of dollar-per-pound assessments of RFCs have been explored within the RFC users group with interesting results. Such industrial engineering analysis merits further consideration within the RFC technology management arena to define likely technology cost constraints and outcomes.

Figure 5.
Consumer product costs in dollars per pound

Figure 6.
Economies of scale and production

Figure 7.
CRN RFC market analysis

CRN RFC Demo MarketView Software . . .

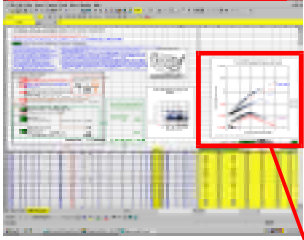

- Originally intended to do RFC market analysis for your service area (CRN Toolkit as Mkt_View.xls)
- Based on 1,500 EIA Census Data Homes
- Inputs include:
 - electric rates,
 - area's natural gas and propane prices,
 - propane tank cost where needed,
 - RFC installed cost and efficiency
 - Thermal Recovery cost,
 - Heat Pump "Dual Fuel" conversion,
 - local climate, etc.
- Annual customer RFC savings or cost for 1,500 EIA Census single family homes reported:
 - by fuel type (Natural Gas / Propane)
 - by BaseloadOnly, Central A/C, Heat Pump
 - by Electric WH, NG WH, Propane WH

Consumer Cost per Pound . . .

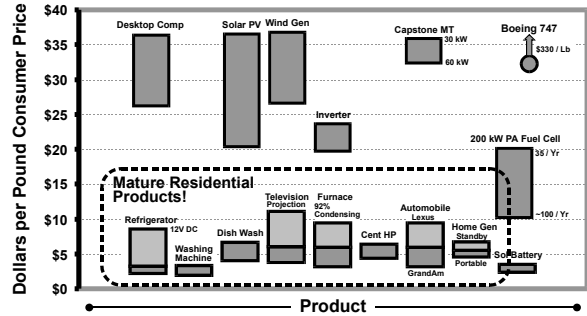

Cost per Unit Output . . .

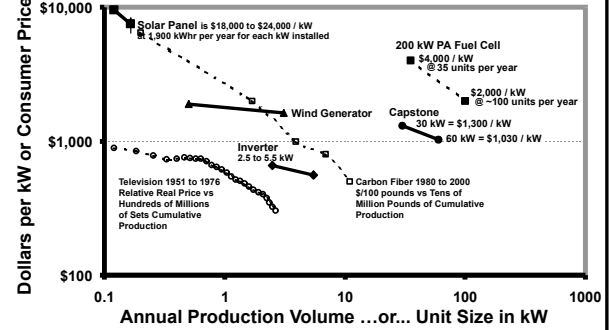

“Catalog” is a Critical RFC Element . . .

If Catalog is only “large” RFC unit:
5 kW Unit at \$6,000 to buy and \$1,500 to install

If add a “small” RFC unit
5 kW Unit at \$6,000 to buy and \$1,500 to install
2.5 kW Unit at \$3,800* to buy and \$1,500 to install
* Calculated by “Economy of Scale”: $(2.5/5)^{0.66}$

If decide to make only “small” RFC units
Large Customers:
2 @ 2.5 kW is \$5,600* to buy and \$2,000 to install
Normal Customers:
2.5 kW is \$2,800* to buy and \$1,500 to install
* Calculated by “Partial Economy of Production” which is: $(8.7/2.4)^{\text{one-third of } -0.62}$

RFC Economic Market per 1,000 Dwellings

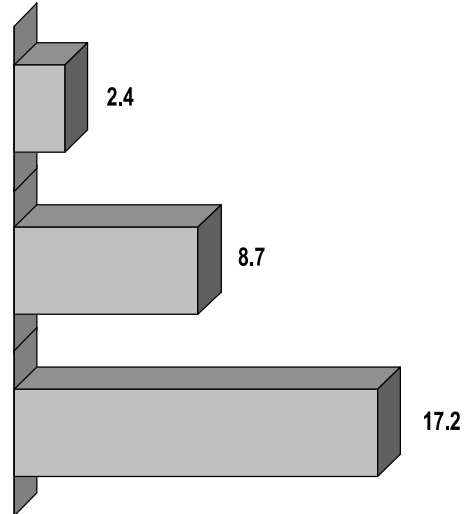

Figure 8. Manufacturer RFC catalog selection effect

Figure 6 shows another well-defined industrial engineering concept particularly germane at this stage of RFC development and technology planning. This applies to economies of scale in equipment sizing and economies of production in fuel cell market planning. Initially developed by the chemical industry and well honed by other industries, these concepts reveal that increasing the size of plants or products reduces capacity-related costs such as dollars per kilowatt or investment per pound of chemical produced. Indeed, manufacturers' price lists and consumer catalogs are replete with examples. Also confirmed by microturbine pricing, the related factor is remarkably consistent at around 0.65. For example, assume that a 5-kW RFC costs \$15,000, which equates to \$3,000/kW. Then a 10-kW fuel cell at the same production volume would cost $(10 \text{ kW} / 5 \text{ kW})^{0.65}$ or 1.57 times as much (\$23,500). Thus, by doubling the size of the fuel cell power plant, the effective unit cost would decline from \$3,000 to \$2,350/kW. However, making RFC power plants larger to reduce capacity costs will almost certainly reduce market sales. Reduced volumes will then actually wind up increasing fuel cell power plant costs.

Likewise, historical product-cost studies have shown that product prices decline as cumulative production quantities increase. Some of this reduction is due to the spreading of overheads over larger volumes, but most of it is simply finding better and cheaper ways to build things as production experience and technology knowledge increase. Typical factors range -0.62–0.66 for three relatively technical products: television sets, carbon fibers, and the projected 200-kW phosphoric acid fuel cell. This means that each time cumulative production doubles, the product price should decline by a factor of $(2/1)^{-0.65}$ or 0.64. In other words, for a product in relatively "commercial" production, the price in real then-year dollars should decline by 37%. Although there can be debate about when cumulative production really starts relative to initial test unit manufacture or exactly what the economy of production number is to two decimal places, there can be no doubt that it exists in fuel cell manufacturers' minds. They are looking for increased sales to enable fuel cell power plant costs to be reduced.

The third tool in this analysis is shown in Figure 7. It is the CRN RFC market analysis program. This software allows co-ops to gain an intuitive, graphic understanding of their potential fuel cell market and how customer size, type of water heating, fuel prices, and electric rates affect that market. The software uses input data from DOE's Energy Information Administration. This agency conducts periodic surveys of residential energy use and markets. The 1993 survey collected data from more than 7,000 residential consumers across the country and from all 10 census divisions. These census areas are actually sub-sampled for city, suburban, town, and rural locations. Because anonymous data files are available for each interview, it is possible to construct a picture of related dwelling characteristics by geographic region and within various environments with database software. This survey also collects annual electric use when possible and includes a detailed appliance and space conditioning survey.

The spreadsheet program incorporates the 1,732 samples in the survey for which detailed consumption is available from actual utility bills. Only homes or one-family attached dwellings are included. Projected RFC and installation costs, including thermal recovery and propane tanks when necessary, are then calculated for each dwelling. Options also allow for the escalation of fuel prices and electric rates. The program then calculates the cost of an RFC for homes not using electric resistance heat and determines whether each customer would have saved money on an annual basis. The results are rendered more useful by referencing census region composites with reporting as “RFC Economic Market per 1,000 Customers.”

This model has proved unusually flexible and can even incorporate a catalog of prospective fuel cell power plants so customers can choose the unit that best meets their electric needs. It has been principally used for sensitivity studies, and some of the major results are reported in the market section of this report. Because the model is principally for sensitivity studies, the important results to look at are relative differences, not the actual numeric magnitudes.

Indeed, to even “turn the model on” for usable results for this particular study, assumptions had to be made:

- Electric rates were assumed to increase 25% over 2000 levels.
- Natural gas fuel cell residences were assumed to have a special rate that reduces fuel by \$1/million Btu.
- Customers were assumed to perceive intangible benefits, largely electric outage insurance, of \$30 per month.

That these energy price adjustments are needed also illustrates how aggressively low the price of a non-remote, grid-parallel RFC needs to become to be economically attractive in today’s world.

The normal market without a manufacturer catalog is represented by the upper bar of Figure 8. This rather low market performance results from a traditional approach of manufacturing a one-size-fits-all 5-kW RFC that costs \$6,000 to buy and \$1,000 to install. The model forces an immediate, but often overlooked, realization that customers are not buying a dollars-per-kilowatt fuel cell power plant; they are instead buying a \$7,000 one-size-fits-all box, irrespective of their actual needs. The projected relative sales of “economic” RFCs are 2.4 per 1,000 dwellings. However, one of the benefits of the CRN RFC market analysis program is spreadsheet flexibility to gain better market understandings. After deducting electric water heaters destined for thermal recovery, the model shows 80% of RFC customers have an average annual use of less than 1.6 kW.

Thus, perhaps the manufacturer should add a smaller unit to the catalog and assume it will sell an equal number of units. It will cost more per kilowatt but less in total cost. This presumes customers will be content with no prospect of running central air conditioning during a grid outage. The middle bar shows the resulting calculations based on economy-of-scale data extracted from Figure 6 results. The second, smaller 2.5-kW unit is projected to cost \$3,800, a 27% increase in dollars per kilowatt, and the same \$1,000 to install. As a result of offering a second unit that is smaller in absolute cost but more per kilowatt, the number of economic customers actually increases by more than 250% to 8.7 per 1,000 customers.

Now assume that the manufacturer recognizes internal production costs have gone down because of the increase of economic customers and decides to offer only 2.5-kW units. Those customers that need a 5-kW unit can instead buy two 2.5-kW units. If even one-third of the –0.62 economy of production was recognized, the purchase price of the 2.5-kW unit would drop from \$3,800 to \$2,800 per RFC. The resulting “economic” market would increase yet again, in this instance from 8.7 to 17.2 per thousand dwellings.

Thus, the manufacturer RFC catalog selection example illustrates the importance of manufacturer, industry, and research agency understanding of how economies of scale and production couple with market profiles in a complex development undertaking such as that of RFCs. The fact that these analyses were conducted under the CRN RFC users group aegis also illustrates the value of having such range-finding analyses as the CRN RFC demonstration program within the DOE-NREL program.

1.5 Funding and DOE Leveraging

The structure of the CRN program enhances leveraging of DOE-NREL funding. As shown in Figure 9, the CRN RFC demonstration program is extensive and costs more than \$1.9 million.

Included are important adjunct efforts in interconnect testing and the highly detailed DG interconnect manual published by the National Rural Electric Cooperative Association (NRECA). This electric grid interconnection guidebook has been specially developed at NRECA. This publication’s 105 pages detail not only how to implement the 1547 guidelines but also the background of related technical issues and how the standard is supposed to work. The Electric Power Research Institute (EPRI) has also joined the RFC users group, and related arrangements have been put in place to supply certain data.

As a result of these CRN efforts, the DOE-NREL component is leveraged significantly compared with the overall program effort of more than \$1.9 million. The DOE-NREL portion is approximately \$100,000 for the first year of the planned 3-year period. This represents a relatively small percentage of the overall CRN RFC program implementation cost.

Three Year Effort; Significant DoE-NREL leveraging

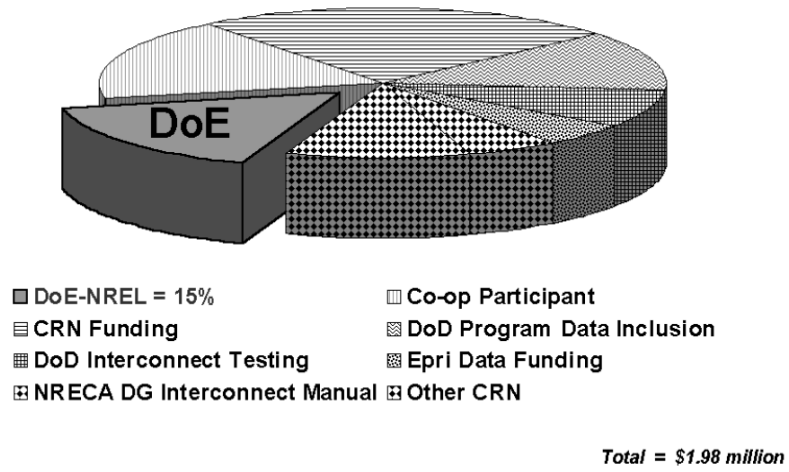

Figure 9. Cooperative Research Network residential fuel cell demonstration funding

2 Accomplishments

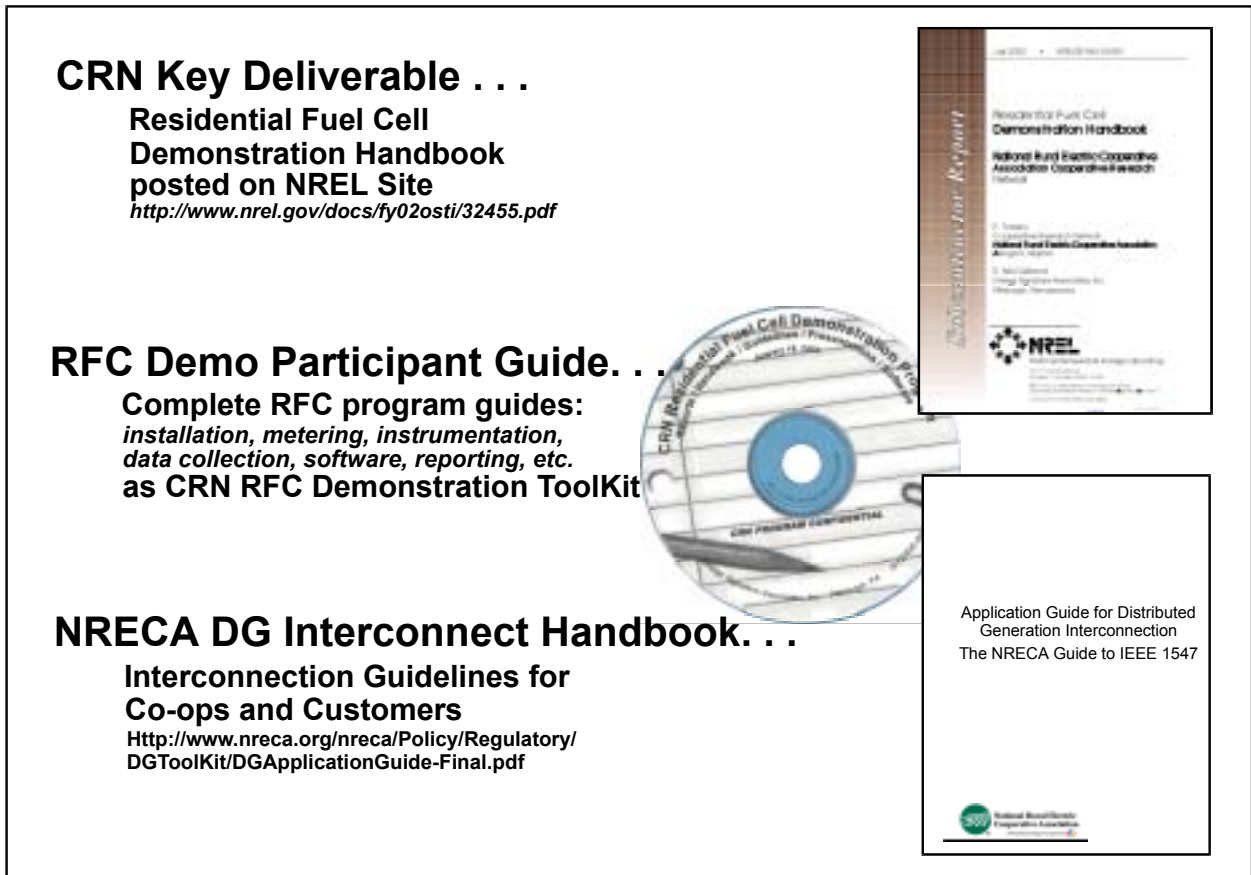

Figure 10. CRN residential fuel cell program key accomplishments

2.1 Demonstration Handbook

The CRN “Residential Fuel Cell Demonstration Handbook” (NREL/SR-560-32455) is a comprehensive guide to RFC technology and issues. This subcontract deliverable covers fuel cell technology, demonstration planning, and reporting. The report describes electrical installation and interconnects, including grid-parallel, grid-independent, and dual-mode operation. Furthermore, key interconnect issues are examined, including 1547 islanding, flicker, and power quality. These are used to develop electrical interconnect configurations and metering and instrumentation guides.

Natural gas, propane, and methanol fuel chemistry; interconnects; and likely costs are covered in a fuel section. This continues with analyses of fuel availabilities and costs as well as some potentially serious environmental and safety issues associated with site storage of methanol. Feed water supply and quality—including makeup water and applicable regional water qualities—as well as pretreatment options and costs are detailed.

A substantial portion of the handbook covers thermal recovery, a key element of RFC economics. Options and their costs are examined. This is complemented by an extensive review of thermal recovery integration with heat pump installations, including various thermal recovery configurations and their installation costs. Operating energy requirements for the key climatic regions of the country are detailed. Also developed are design and instrumentation parameters. The handbook can be found at <http://www.nrel.gov/docs/fy02osti/32455.pdf>.

2.2 Co-Op Distributed Generation Interconnection Handbook

This DG interconnection handbook has been specially developed through NRECA, the parent of CRN. Its goal is to help move DG and its application into general use. All IEEE 1547 guidelines and their applications are detailed. The handbook is more than a list of regulations. Developed for co-op personnel and their customers, its 105 pages explain the intent of regulations, why they are technically necessary, and implementation specifics.

Although prepared separately from the CRN RFC demonstration program, this application guide for DG interconnection is a pre-planned component of CRN RFC activities. It is complementary to the electrical interconnect demonstration and analysis that are a major part of this CRN-DOE project. This DG interconnect manual is available to the public and industry at <http://www.nreca.org/nreca/Policy/Regulatory/DGToolKit/DGApplicationGuide-Final.pdf>.

2.3 Cooperative Research Network Residential Fuel Cell Demonstration Tool Kit

2.3.1 Interface Installation and Metering Guidelines

The CRN RFC demonstration has multiple goals. A key component, of course, is to demonstrate and assess fuel cells as a residential DG technology. Successful implementation depends on well-planned installations and relevant data collection. This necessitates the development of comprehensive guidelines for electrical, fuel, thermal recovery, and water interconnects for internal program management. Guidelines will also help in the detection and assessment of issues that will ultimately affect successful demonstration and, more importantly, practical future market applications of DG. CRN has developed a CD to provide these guidelines. Although the CD is not a specific subcontract deliverable, its guidelines and user group analysis presentations are a major input into the results reported here as an NREL program deliverable.

The tool kit includes guidelines for:

- Electrical interconnect and metering (21 pages)
- Natural gas and propane supply, interconnect, and metering (21 pages)
- Thermal recovery planning and metering (9 pages)
- Data collection and instrumentation (18 pages).

These guidelines not only address specific issues and concerns of installation but also specify interconnect and metering equipment, costs, and procedures.

2.3.2 Letter Reporting

To provide consistent reporting that extracts maximum value from the program, a number of letter reports have been developed for participant use. To provide consistency and manage resources, this reporting has been designed to be “point and click” or survey-like in implementation while capturing all needed details. The specially prepared reporting included in the tool kit includes:

- Site Selection and Installation Planning Letter Report
- Environmental Checklist Letter Report
- Water Testing Guideline and Letter Report
- Site Energy Survey Letter Report
- Electrical Interconnect Letter Report
- Installation Cost Spreadsheet Letter Report
- Commissioning Letter Report
- Fuel Cell Power Plant Service Report
- Monthly Meter Reading Collection Sheet.

For grid-parallel-capable RFC power plants, the interconnect letter report reviews the interconnection protocols as reported by manufacturer specifications and installation service manuals. The feeder and distribution laterals to the fuel cell installation and the size of the interconnect transformer are defined. In the unlikely event that additional interconnection protective relaying is required, the interconnect letter report provides the rationale and describes added protective relay functions.

The fuel cell power plant service report is designed for ready input into specially developed database software and covers scheduled or unscheduled maintenance, shutdown causes, service hours, manufacturer response and parts availability, and site service call information. In addition to being a useful site log and troubleshooting reference, this straightforward form provides a low-effort means of collecting reliability and service incident data. When a copy of the field report is forwarded to EnSig, the information is put into a database for automatic distribution to the originating co-op and all demonstration participants.

This service report database software enables participants to pull up and print out all shutdown or service incidents of their or any other demonstration fuel cells. Users can also see how other participants rate such things as manufacturer equipment design, access, and support. Moreover, the preprogrammed software built into the database calculates, prints, and plots raw or corrected mean time between forced outages, corrected availabilities, etc., for individual fuel cell units or for the program. The database can also search for type of incident and automatically generate availability and reliability reports for internal management and CRN demonstration program reporting.

2.3.3 Software

The tool kit also contains spreadsheets developed for the management of the CRN RFC demonstration program. The goals of this effort are to:

- Maximize reporting accuracy and enhance related analyses by the CRN program and individual participants
- Enable the most efficient use of resources by participant and program personnel so maximum effort can be spent on thoughtful analysis rather than data manipulation.

The tool kit includes:

- A monthly meter-reading tool with calculations and analysis graphs
- Calculation of export power profiles
- Calculation of allowable HP, AC, or motor start sizes
- Field calculation of instantaneous RFC efficiencies
- Field analysis of RFC harmonics
- Calculation of RFC buss bar electric cost, including any thermal recovery credit
- A thermal recovery mapping tool with graphic analysis
- A market view analysis program
- An installation cost-estimating tool.

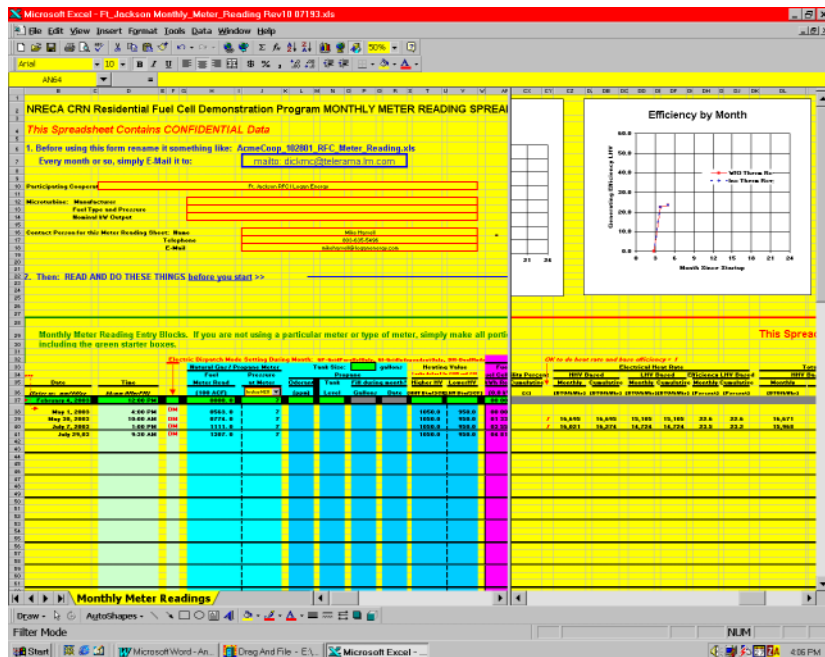

Figure 11. Monthly meter-reading tool (Fort Jackson data)

To date, the most popular and widely used software for field site use has been the monthly meter-reading tool. Its automated capabilities and calculation flexibility make it easy to acquire field data. This flexibility is complemented by the automatic production of availability and efficiency graphs, which make field-results monitoring easy and efficient. Thus, it is embedded in many of the DOD military base fuel cell demonstration installations.

2.4 Installation Cost-Estimating Tool Results

2.4.1 Commercialization Importance

The software that may have the farthest-reaching and most valuable effect on real RFC development is the installation cost-estimating program embedded in the CRN RFC demonstration tool kit. This spreadsheet analysis program was initially intended to help co-op participants develop budget cost estimates for RFC demonstration installations. However, it has become an invaluable tool for studying the ultimate market acceptance of future commercial RFC applications for DG use.

The real user cost of an RFC is its actual installed cost, not merely its technology goal of dollars per kilowatt in manufacturing cost. To a customer, technology manufacturing prices—commonly followed as dollars per kilowatt—are indistinguishable from installation costs needed to make it work in his dwelling and on the grid. Perhaps because of the lack of demonstration experience such as in the CRN RFC demonstration program, little attention has been paid to the cost of installing a unit, connecting it to the grid and fuel supply, and recovering meaningful amounts of thermal energy.

A contributing factor may be that many estimates consider the installation cost to be a uniform dollars-per-kilowatt figure when, in fact, the cost of installing a 3-kW RFC is not materially different from the cost of installing a 7- or 10-kW unit. The estimates presented in Table 1, and now validated by initial demonstration experience, indicate that even if the fuel cell were free, the installation cost would be about \$2,000/kW for a propane-fueled unit and around \$1,500/kW for a natural gas solid oxide RFC. Put differently, even if a residential solid oxide fuel cell were to achieve an admittedly laudable technical goal of \$500/kW, the actual installed application cost seen by a real customer would be four times higher in dollars per kilowatt.

The ultimate goal of the CRN DG effort is to have RFCs make a meaningful DG contribution to the grid. Early on, the program made a conscious decision to share all information and tools with manufacturers participating in the program. This is based on the belief that the more manufacturers are informed of actual market needs and present issues, the better the chance their effort will achieve those needs and resolve related issues. For example, the CRN installation cost-estimating program is now being used by DOD's Construction Engineering Research Laboratory and its major contractor in the program to better estimate and manage RFC installation costs at military base sites.

As a result of keen commitment to the CRN RFC demonstration program, an effort is now under way—principally through work under the companion CRN RFC users group—to improve installation cost performance for the benefit of industry and to help meet DOE’s technology goals. These efforts are wide-ranging. They concentrate on more cost-effective materials, improved designs, and site installation techniques. For example, extensive work is under way to refine and simplify thermal recovery installations. Several systems have already been identified to reduce fuel equipment and installation costs for thermal recovery. In addition, an alternative residential air conditioner pullout disconnect system has been identified to reduce grid disconnect costs, and an easy-to-install and relatively inexpensive generator panel is being demonstrated to reduce critical load electrical interconnect installation costs.

Table 1 highlights the resulting programmatic installation costs and illustrates the flexibility and completeness of the installation cost-estimating program spreadsheet.

Table 1. Installation Costs for Residential Fuel Cells in the Cooperative Research Network Demonstration Program

RFC Installation Component	Total for Demo Unit	Less Metering and Data Collect	Normal RFC Installation
Site Install: Delivery, pad, and set RFC	\$1,150	0	\$1,150
Fuel: Propane tank, regulators, gas meter, piping, gas sampling, etc. (500-gal buried tank)	\$4,650	\$2,310	\$2,340
Electrical: Grid interconnect CB, wiring to RFC, disconnects, electric meter, critical load panel, wiring to critical load panel, telephone, etc.	\$3,050	\$770	\$2,280
Thermal Recovery: Thermal recovery tubing, insulation, trenching, Rheem Solaraide tank, circulating pump, expansion tank, TPRV, anti-scald valve, bleeds, temperature control, Btu meter, etc.	\$5,440	\$1,810	\$3,630
Water Drain: Water supply tubing, heat tracing, trenching, line tap, etc.	\$1,320	\$190	\$1,130
Data Collection and Instrumentation	\$2,890	\$2,890	0
Total	\$18,500	\$7,970	\$10,530

2.4.2 Methodology

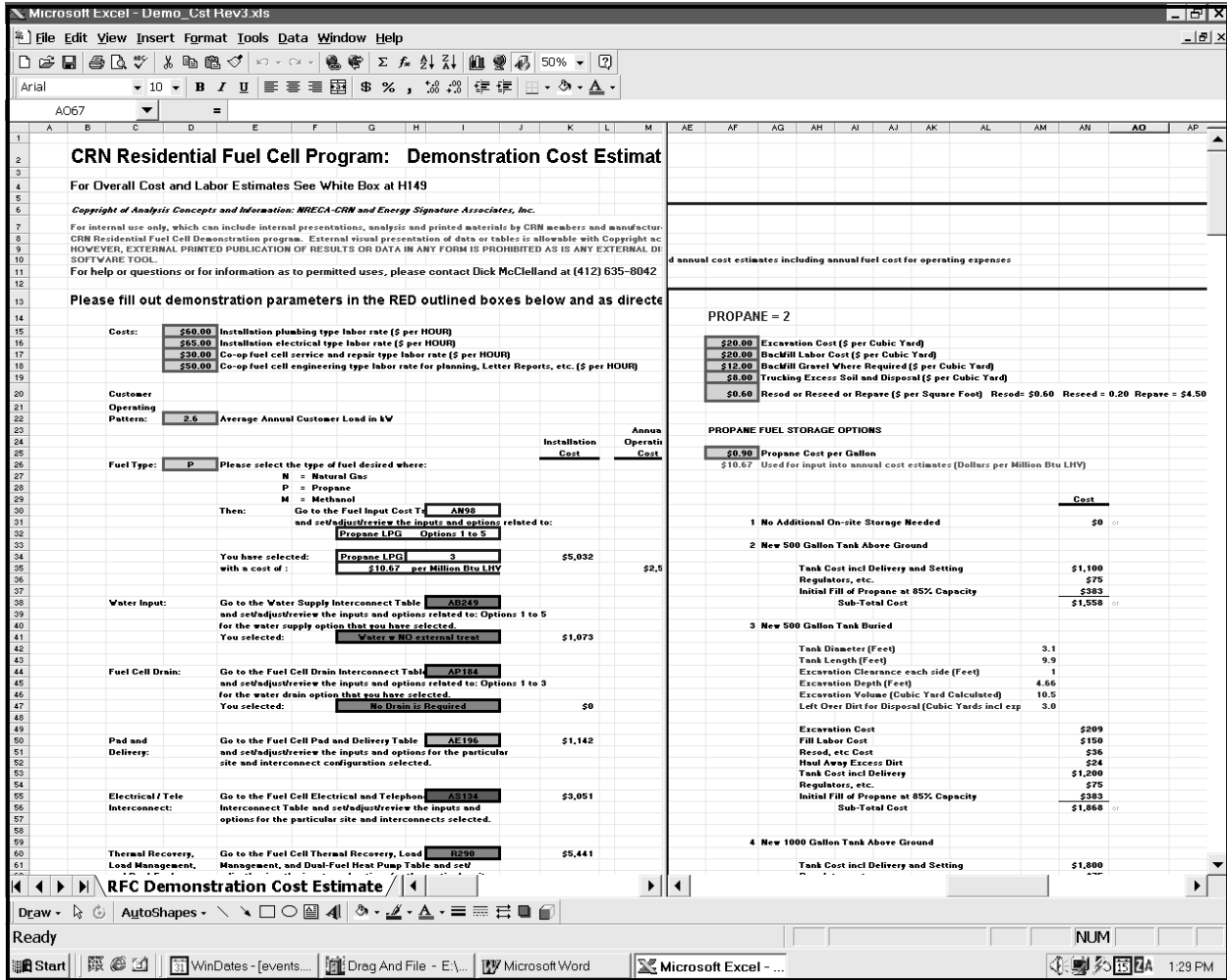

Figure 12. Installation cost-estimating spreadsheet program

As illustrated in Figure 12, the installation cost-estimating program divides installation costs into categories such as propane fuel, installation and pad preparation, other fuel supply and interconnects, electrical metering and interconnect, water supply, thermal recovery and interconnect, and instrumentation and data collection. Within each section, the user can toggle selections and make inputs. For example, in the electrical metering and interconnect area, the user toggles the types of equipment—such as disconnects, automatic transfer switch, main lug panel, interconnect circuit breakers, critical load panel, and kilowatt-hour meters—required.

The distances between equipment and whether wiring is buried, in conduit, or indoors are then entered, and the program automatically calculates relevant equipment costs and electrician labor hours. To provide user-friendly performance, the program incorporates labor hours necessary for the installation of specific items and unit distances based on composite analysis using RSMMeans elements. These are combined with pre-entered equipment supplier quotations for automatic generation of cost estimate details and composite totals.

Propane fuel interconnects allow for existing tanks and options for new 500- or 1,000-gal tanks that are aboveground or buried. Thermal recovery includes more than a dozen clearly identified and organized options and combinations. These include:

- Creating a potable water loop from the existing water heater
- Installing a solar coil preheating tank in front of the existing water heater
- Replacing the existing water heater with a CombiCor coil water heater that is regular or power-vented
- Adding a supplemental coil to replace the existing heat pump supplemental electric heater
- Coupling the coil with a new instantaneous indoor or outdoor water heater
- Replacing the existing heat pump air handler with a new, sealed combustion high-efficiency furnace to make a dual-fuel heat pump installation.

Within each option, elements such as circulating pumps, thermostatic controllers, expansion tanks, air bleeds, anti-scald valves, and propylene glycol antifreeze fill can be toggled off or on. The program also collects distances, wall penetrations, and insulation and heat-tracing inclusions to calculate plumbing labor and materials costs for pipe runs. For makeup water supply, the user can enter water quality and select types of water pretreatment, including reverse osmosis and demineralizer cartridge systems. The program then calculates installation and annual cartridge replacement costs.

The software program spreadsheet is easy to use. Point-and-click toggle entries and a few distance entries can yield a detailed RFC installation cost—including complex thermal recovery and grid interconnects—in only 10–15 min. Furthermore, this program worked hand in hand with the CRN RFC demonstration initial field installation experience to validate inclusions and cost-estimating techniques. The overall RFC installation cost results are shown in Table 1.

2.5 Cooperative Research Network Residential Fuel Cell Users Group

RFCs face challenges if they are to be widely used as a DG resource. The 3- to 10-kW fuel cells are smaller in capacity and higher in unit cost than those used for commercial building or transportation applications, which are in the 50–200-kW range. Thus, the capital cost of the equipment is relatively high. In addition, the peak-to-average use of a typical residential consumer connected to a power plant is high. To achieve commercial market pricing, hundreds, if not thousands, of units will need to be produced and sold by a manufacturer. Misjudged customer needs or cost sensitivities, inappropriate catalog selections, high installed costs, under-implemented market plans, or missed production cost goals will have a major effect on success, as will the more easily measured, readily visible technology failures such as unacceptably low cell stack lives or grid interconnect shortcomings.

Thus, market and application areas are just as crucial as fuel cell technology elements. For these reasons, an integral part of the CRN RFC demonstration program has been the full integration of a CRN RFC users group within the composite program umbrella. This CRN RFC users group is open to all participants in the program, including CRN co-ops (whether or not they have a demonstration unit), DOD-Construction Engineering Research Laboratory personnel engaged in that group's RFC demonstration, and DOD-Construction Engineering Research Laboratory contractors that have sites embedded in the CRN RFC demonstration program. An embedded DOD site agrees to meter and instrument its installation using CRN RFC demonstration tool kit guidelines and to report data and experience to CRN standards. The inclusion is synergistic and benefits both parties. Embedded sites have access to CRN RFC tool kit resources and software; the CRN demonstration program has access to that site's data and experience.

In addition, EPRI has asked that its members be permitted to be members of the group in return for related shared data. Manufacturers with RFCs also have full access to the CRN RFC demonstration tool kit and are invited to attend meetings except when other manufacturers or proprietary data are discussed.

The users group enhances the transfer of information, ideas, and assessments among all program participants. It is also a valuable communications channel for all participants during the site selection, installation, and initial results collection of demonstrations. It enables participants to become more familiar with the actual field operations of the technologies, better assess the manufacturers and their equipment, and maximize feedback to the manufacturers.

Concurrently, the users group provides a mechanism through which common issues, needs, and efforts can be addressed to benefit the productivity and efficiency of all participants. Examples include an early-entrance market definition, overall economic quantification, service and maintenance issues, system dispatch and monitoring needs, and business issues and criteria.

In effect, the users group began at a 3-day kickoff seminar attended by more than 60 co-ops that:

- Detailed fuel cell technology
- Introduced prospective RFC manufacturers
- Described demonstration objectives and implementation
- Explored key applications, economics, and markets.

Since that time, four CRN RFC user group meeting-seminars have been held. These meetings encompassed more than 50 specially prepared analyses and presentations involving weeks of program labor and hundreds of pages of PowerPoint presentations.

Examples of these work areas are:

- Electrical interconnect and metering
- NRECA DG interconnect guidelines
- Distribution interconnect issues analysis
- Electrical interconnect for 120-V units with critical loads
- Motor start capabilities of central heat pumps
- RFC laboratory performance and certification test protocol
- Thermal recovery implementation
- Water heating thermal recovery application
- Propane and natural gas fuel interconnects
- Propane fuel quality issues
- EPRI RFC market study
- Unscrambling the RFC market
- Overall market applications and costs
- Market size, sensitivity, and catalog issues
- Co-op RFC features-implementation market survey
- Application to heat pump dwellings
- Remote application market analysis
- Remote market comparative costs (PV, wind, engine, RFC)
- Economies of scale and production analysis
- PEM versus solid oxide RFC technology
- RFC tool kit contents and use
- Site selection procedures and elements
- Letter reporting needs and guidelines
- Instrumentation, metering, and data collection planning
- DOD-Construction Engineering Research Laboratory program
- Propane educational research organization.

3 Electrical Interconnect

3.1 Application Configurations

All the manufacturers ultimately plan to develop RFC power plants capable of grid-independent operation. Most will also be capable of running in a grid-parallel mode. Although grid interconnect protection is an important issue, the practical design needs for a grid-parallel fuel cell are the relatively straightforward development of IEEE 1547 and a related detection and control card capable of interrupting the unit's inverter in the event of a grid upset. The design of an RFC for grid-independent operation is in some ways more challenging because the unit's control system, inverter, and fuel processor need to be able to respond to wide load swings while consistently producing grid-quality power.

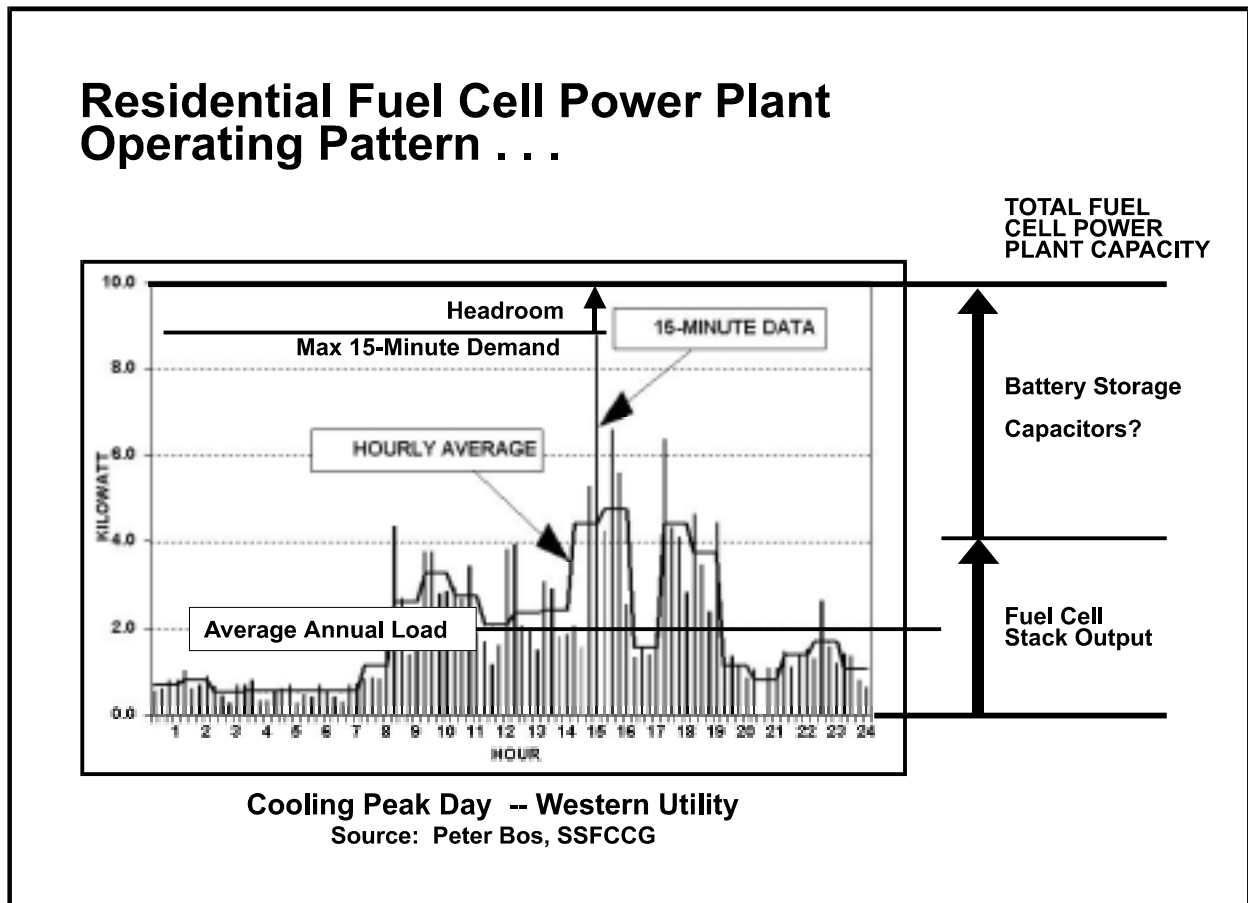

Figure 13. Fuel cell load application profile

Thus, RFC units are being planned with the capability of satisfying two distinct markets. The first is isolated operation at remote sites; the second is DG on the grid. Indeed, because of the first cost of alternative equipment and the potential to offset \$10,000 plus per mile of single-phase line extension, manufacturers increasingly see propane-fueled remote market fuel cells as an early-entry market for initially higher-cost RFCs.

Both modes of operation are important to co-ops and their operating regions. For example, given reasonable reliability and costs, grid-independent operation can provide co-ops and their customers with a potential alternative to costly line extensions for distant small loads. Conversely, grid-parallel units—particularly those with remote dispatch for daytime power output in excess of customer loads—can provide an added dispersed generation grid source while enhancing customer appeal if they can automatically disconnect from the grid and run in a grid-independent mode during a grid outage.

As noted in Figure 14, typical RFCs are inherently designed with at least optional battery capacity. This helps serve remote applications with grid-independent daytime peaking loads within the dwelling. Such capability also benefits DG applications. For example, to the extent that at least some battery and charger capacity are already built in, it is conceptually possible in the future to have a smaller cell stack that uses both its output and the grid at night to charge its batteries for full daytime operation.

Indeed, co-ops responding to the RFC features survey conducted as part of the CRN RFC users group felt such a system would be both useful and acceptable, even if the unit needed to rely on the daytime grid for some motor starting load capacity. Thus, an RFC unit could even function as a combination DG and day-to-night load leveling device. As a result, this demonstration program is assessing both grid-parallel and grid-independent modes of operation.

3.2 Interconnect Configurations

3.2.1.1 Grid-Parallel

Most commercial and many demonstration RFCs have the ability to operate in grid-parallel and grid-independent modes. As shown in the first box of Figure 14, power flows from the fuel cell to the customer's dwelling and may also flow to, or from, the grid. The timing, amount, and direction of power flow relative to the grid depends on:

- Whether the unit is configured during operation to act as a distributed generator with export power to the grid
- The fuel cell power plant's cell stack and battery capability relative to the dwelling's load at that particular instant
- The dwelling's daytime/nighttime and on-peak/off-peak relative loads
- Whether any anti-export controls are present and activated in the unit or at the site.

Thus, the flexibility of this configuration of RFC has *two* types of interconnect criteria. The first of these is a grid-parallel interconnect configuration.

Grid-Parallel

Power Flow:

Power flows from the fuel cell to the customer's dwelling and to/from the grid, both of which are connected in parallel. Depending on the time of day, fuel cell capacity versus dwelling loads, the state of fuel cell battery charge, and any anti-export controls or settings, power may flow from or to the grid. The typical configuration would likely have limited export at certain times of the day and strive for no export at night.

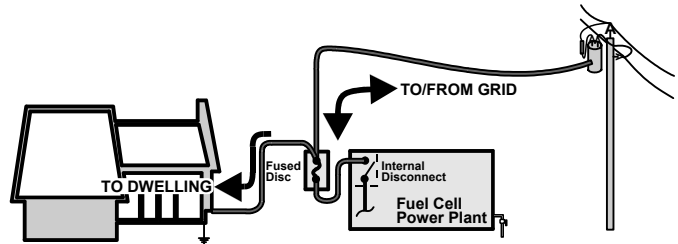

Interconnect:

The fuel cell interconnects with the grid through a fused disconnect, which is accessible to distribution service personnel, and an internal disconnect under control of the power plant. In the event of a short-term grid upset, the inverter typically interrupts or stops commuting. In the event of a longer upset, the inverter opens an internal disconnect and likely goes to idle while monitoring the grid and waiting to reconnect after a preset time delay after the grid returns to normal.

Key Interconnect Issues:

Grid: Grid interconnect issues regarding islanding, reconnect timing, etc. Some interest in power quality.

Customer: Potential power quality-type issues depending on grid versus power plant stiffness.

Grid-Independent

Power Flow:

Power flows only from the fuel cell to the customer's dwelling. Thus, the fuel cell must meet all dwelling loads. This requires application preplanning and perhaps load monitoring before installation. The fuel cell will likely have a substantial battery storage system charged by the cell stack at night to supplement the cell stack during peak daytime loads.

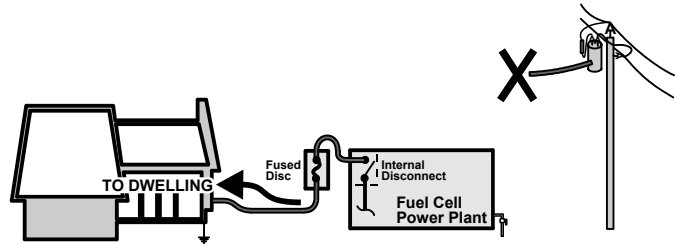

Interconnect:

The fuel cell connects to the dwelling through a fused disconnect and perhaps an internal disconnect for certain fault-clearing events.

Key Interconnect Issues:

Grid: None.

Customer: Potential substantial power quality-type issues depending on customer and loads.

Dual Mode (Combination Grid-Parallel and Grid-Independent)

Power Flow:

Power flows from the fuel cell to the customer's dwelling and to/from the grid in normal operation. In the event of a grid upset, the power plant interrupts. In the event of a serious grid event, it disconnects itself and the dwelling from the grid and runs independently. After a suitable delay after the grid returns to normal, the inverter interrupts, and grid-parallel operation is restored.

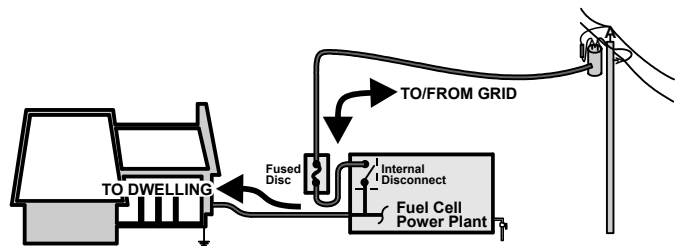

Interconnect:

The fuel cell interconnects with the grid through a fused disconnect. An internal fuel cell disconnect is provided for certain grid-parallel upsets and may be provided for certain dwelling grid-independent fault-clearing events.

Key Interconnect Issues:

Grid: Grid interconnection issues regarding islanding, reconnect timing, etc. Some interest in power quality.

Customer: Potential substantial power quality-type issues depending on customer and loads.

Figure 14. Residential fuel cell interconnect types and issues

Grid-parallel is the first, and most critical, of the fuel cell interconnect configurations. Important considerations are the ability of the unit to follow the grid's voltage and frequency over an acceptable range and halt power production in the event of a grid upset beyond stated limits. It is crucial for the power plant to reliably detect a grid outage and promptly halt power production so it does not hinder recloser operation or island. Islanding is the introduction, or potential introduction, of power into an otherwise dead grid. This poses a serious hazard to co-op distribution service personnel attempting to repair grid service.

An additional criterion is the power quality interconnect, principally with the customer and secondarily with the grid. This encompasses such elements as voltage sags and swells, flicker, harmonics, DC power components, and secondary factors. The level of concern is a function of the power quality from the fuel cell power plant, the customer's loads, and the relative stiffness between the grid and fuel cell at the customer's load point. Because grid stiffness is generally high relative to the fuel cell's capacity, power quality is generally not an issue given a reasonably well-designed inverter.

3.2.1.2 Grid-Independent

The middle box of Figure 14 shows the same fuel cell power plant in a grid-independent interconnect configuration. In this instance, power flows only from the fuel cell power plant to the customer's dwelling. There is no connection with the grid, except perhaps a manual or automatic transfer switch that allows the customer's dwelling to use either fuel cell or grid power. Because there is no ability to connect the fuel cell with the grid, no grid interconnect concerns exist.

However, in this instance, the fuel cell must meet all the dwelling's loads and can expect no support from the grid. Thus, the fuel cell will likely have a battery storage system sized to be equal to or greater than the cell stack's capacity. The batteries are charged by the cell stack at night during off-peak hours and used to supplement the cell stack's capacity during daytime peak loads. Such an installation requires demonstration program preplanning and most likely some pre-installation metering to ensure the customer's load will not exceed the fuel cell's capacity. In addition, if some type of wiring segregation is not used, load shedding or load control devices may be required, and the fuel cell may need some type of internal disconnect for certain dwelling fault-clearing events.

In this instance, power quality interconnect would be of reasonable interest to the dwelling customer but not to the grid. Of keen interest would be voltage regulation with regard to sags, swells, spikes, and other elements, particularly when large loads such as a heat pump compressor are added or removed from the fuel cell power plant's load. Other elements of interest may include flicker, harmonics, and DC voltage components.

3.2.1.3 Dual Mode (Combination Grid-Parallel and Grid-Independent)

This system would normally run in grid-parallel mode, with power flowing to the customer's dwelling and to or from the grid. The direction of the grid flow would depend on the fuel cell power plant's capacity and DG settings. In its normal grid-parallel mode, the fuel cell power plant would essentially follow the grid's voltage and frequency as long as these parameters were within preset limits. In the event of a grid upset, the power plant would interrupt and wait for the grid to return to normal.

However, in the event of a serious grid upset or power outage, the system would disconnect the dwelling—or a portion of the dwelling called the critical load—from the grid and operate in a grid-independent configuration. This would be accomplished by a built-in automatic transfer device, an external automatic transfer switch, or supplying a portion of the dwelling's need via an added critical load panel. Indeed, considering the likely cost of an RFC in early-entry markets and even in mature markets, an important if not vital selling point will be the ability of any DG grid-parallel fuel cell to provide some type of backup power to the customer in the event of a grid outage. A pure grid-parallel RFC that is incapable of dual-mode operation has limited consumer appeal and is most likely unmarketable to grid customers.

In addition to dual-mode operation, a more mature market power plant might have other options. One of particular interest would be for co-op or customer use as a grid load-shifter. In such an operation, special grid tuning software would be used in conjunction with the pre-existing power plant components, batteries, and possibly smaller cell stack. In implementation, a portion of the nightly battery charge could be supplied from the grid as well as the cell stack. Such a configuration would add to the normal RFC and DG advantages the ability to use the fuel cell's existing built-in battery capability to actually load-shift some or all of the customer's load from on-peak daytime to off-peak nighttime grid supply. This would, however, require a fuel cell that has either a high-efficiency idle mode or a remarkable insensitivity to daily starts.

3.3 Electric Grid Distribution Structure

3.3.1 Background

Although interconnect considerations principally concern the utility grid, components such as voltage and frequency control are important when considering an RFC's effect on the host site's customer. This customer effect is important when the unit runs in both grid-parallel and grid-independent configurations, as illustrated in Figure 14. However, certain critical interconnect considerations—such as a grid-paralleled unit not islanding in the event of a grid outage—are purely grid issues.

The fact that the RFC uses an inverter, sometimes called a static power converter, is an important grid interconnect consideration. This is because an inverter has no inertia. It can instantly connect and disconnect with the grid or customer load and does not have frequency stability problems as its loads change. Also, inverters typically contribute lower fault currents.

Unlike inverters in the 1980s, which used SCRs and produced step wave-associated harmonics, the RFC inverters in this demonstration program use pulse-width modulation and high-frequency synthesis waveform generation with low harmonic distortion. However, to the extent that inverters switch in the 1,500+ Hz range, some generation may exist in the 25th to 35th or higher harmonic frequencies.

3.3.2 Typical Co-op Distribution Configuration

A typical co-op distribution configuration is shown in Figure 15. This is a radial system that branches out from a single point, and from only that original point does power normally feed the system. Although various distribution and grounding systems are possible, one of the most common co-op systems is a multi-grounded neutral system. In a multi-grounded neutral system, the neutral is grounded every one-quarter mile and at equipment stations such as distribution transformers and capacitors. In the 1930s, the Rural Electrification Administration selected this multi-grounded design for rural electrification because of its lower cost and potential for improved relaying of ground faults.

As shown in Figure 15, the system consists of a substation that powers a three-phase distribution feeder. The primary distribution voltages are sorted into classes such as 5 kV, 15 kV, 25 kV, or 35 kV. The 15-kV class is the most popular and comprises about 80% of the circuits within the United States. Within that class, typical voltages are 12.5, 13.2, and 13.8 kV, with a potential normal peak loading in the range of 4,000–6,000 kVA, which would be the equivalent of several hundred amps.

Commercial customers are generally supplied by 480-V three-phase transformers from the main distribution feeder or a three-phase distribution lateral. These feeders and their laterals can be 3–15 miles or longer. In addition, single-phase distribution laterals powered by one of the distribution feeder phases will also probably supply residential and farm loads.

In either case, distribution transformers then feed individual homes and farms, which are typically 120/240 V single-phase for dwellings. In instances in which customers are next to or across the road from one another, a single distribution transformer may feed multiple customers. A typical co-op distribution system for an RFC installation has this three-phase distribution feeder supplying a single-phase distribution lateral, with an individual distribution transformer dedicated to that particular residential load.

As Figure 15 illustrates, one of the potential benefits of DG is a reduction of line losses. In effect, this can be viewed as a direct multiplier of fuel cell efficiency. For example, if a fuel cell power plant has a site fuel-to-power efficiency of 33% but its operation concurrently eliminates 10% of line losses, then the power plant's apparent efficiency is $0.33/0.9$, or 36.7%.

Electric Grid Interconnect Factors . . .

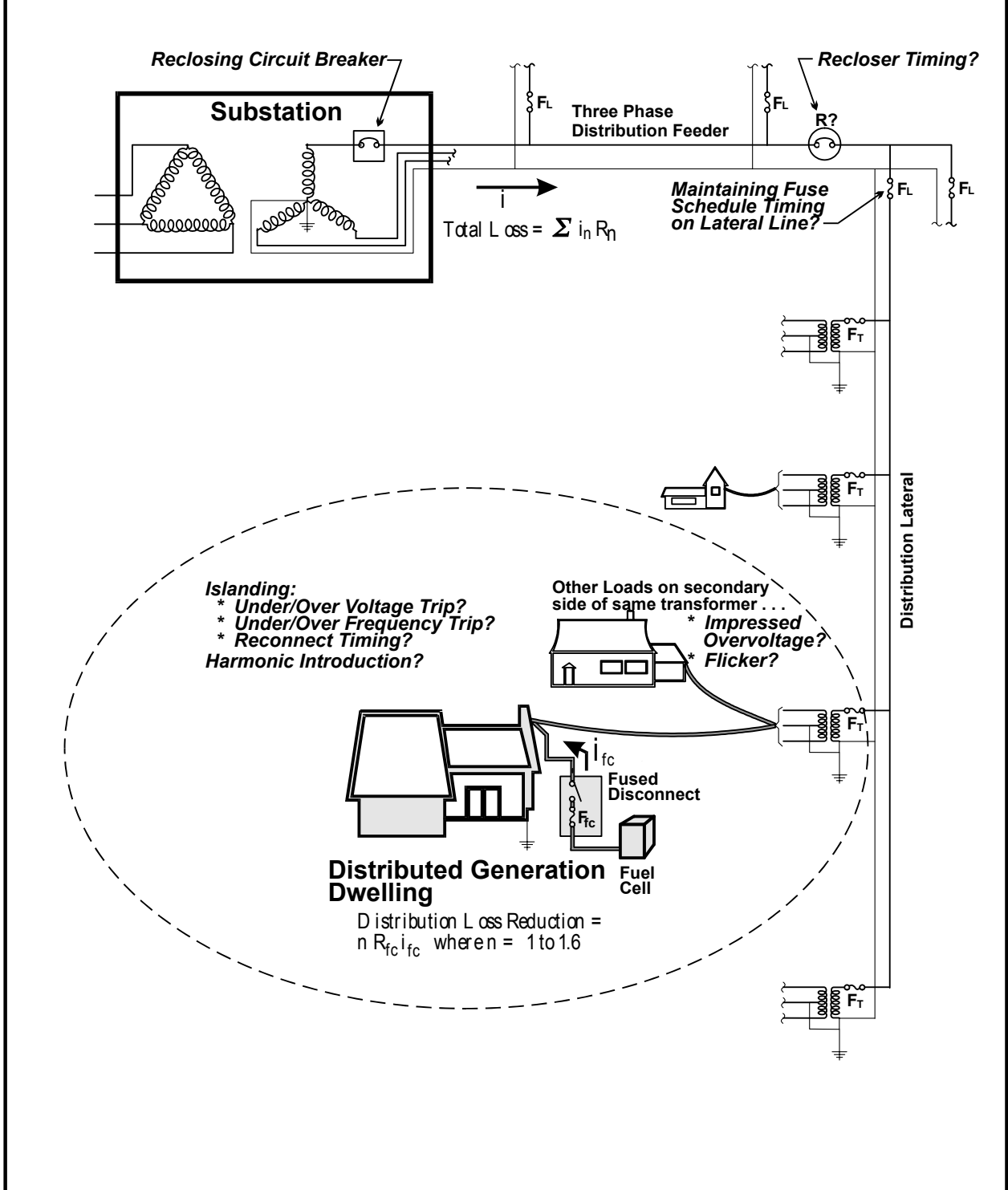

Figure 15. Typical co-op distribution system and fuel cell interconnect issues

Indeed, the same rules generally apply as for locating capacitors. Thus, it is possible to show that optimally placed DG can eliminate as much as 1.6 times its capacity in line losses. However, this presumes a locational flexibility beyond that usually achieved in the real world. Thus, a safer estimate is that no more than the unit's capacity is eliminated in line losses.

Even so, this can be an important benefit and impressive improvement in RFC power plant efficiency, particularly for long, heavily loaded distribution laterals on which a fuel cell is located at the far end. This poses the consideration—already being addressed by a CRN program complementing the CRN RFC demonstration program—of what practices or incentives can be used by co-ops in search of DG capacity to encourage that production at the most helpful points on their distribution systems.

Various grid-connect concerns exist with an RFC interconnection. One class of issues relates to the operation of the RFC in a grid-interconnected mode under ordinary circumstances. As noted next to the DG dwelling in Figure 15, these are normal power quality concerns. Such elements relate to the ability of the fuel cell to successfully interface with the local grid under a suitable range of voltages, frequencies, and harmonics. Because of advances in microprocessor controls, high-frequency switching, and pulse-width modulation waveform generation inverters, these are not likely to be issues with normal RFC applications. A second class of issues is related to the apparent size of the grid relative to the fuel cell. One important parameter is the stiffness of the grid relative to the fuel cell generator.

This stiffness concept, developed in recent years by an EPRI effort, is a good indicator of the degree to which the distributed generator—in this case, the fuel cell—can influence the grid. “Stiffness” is, in effect, the ratio of the grid fault current available at the fuel cell interconnect point to the maximum rated output current of the RFC. In this instance, the stiffness ratio would be equivalent to the sum of the distribution transformer available fault kilovolt-amperes plus the RFC fault kilovolt-amperes divided by the RFC fault current. The greater the stiffness ratio, the less likely the fuel cell can affect the grid.

A set of corollary power quality factors relates more to other customers, if any, on the same secondary side of the transformer, although they would also affect the primary RFC customer. In this case, the applicable measurement is load ratio. This is the sum of the average loads for all customers on the secondary side of the transformer divided by the RFC DG capacity installed on the same secondary side. In this case, concerns include flicker, impressed overvoltages, and even islanding. Islanding is such a critical issue it will be discussed in its own segment.

Flicker could occur in the unlikely event that widely and rapidly fluctuating amounts of power are exported to the grid. Flicker is more of a concern from wind systems than from RFC installations.

Impressed overvoltage is a rather unusual condition in which there are multiple customers in line on the same secondary transformer, the fuel cell installation is at the far end of the line, and the entire secondary voltage normally runs high. Given such a combination and when the dwelling loads are low, excess fuel cell export power—if the system had been set up that way at its installation—could conceivably drive the secondary voltage high as it moved power down the secondary line and through the transformer onto the grid. Of course, if the fuel cell controls had been set to fold back power output under high-voltage conditions, this problem would be unlikely to occur.

3.3.3 Recloser Operation

3.3.3.1 General Experience

Studies and practical experience indicate that 70%–90% of faults on overhead distribution systems are temporary in nature. These faults are caused by circumstances such as contact with tree limbs, birds, or animals; lightning flashover on insulators or crossarms; and conductors swinging together.

System reliability is greatly enhanced by the universal use of reclosing devices. An example is the reclosing circuit breaker shown at the substation in Figure 15. This may be assisted by additional reclosers further from the substation and is, in any event, backed up by fuses on the distribution laterals (F_L) and at the individual distribution transformers (F_T).

Reclosing circuit breakers at the substation and reclosers in the system temporarily interrupt power, pause to allow deionization of the arc path, and then re-establish voltage. Reclosers are typically set for up to three tries before locking out the entire radial distribution feeder. Typical operations might be for the recloser to open to protect the system when the set overcurrent is exceeded for 0.2–5 seconds. If the fault is still present, the recloser will reopen, wait for a few more seconds for any temporary fault to clear, and then reclose. The second and third closure attempts might be for as long as 15–60 s, depending on how the recloser is set. If the fault is temporary, the event will have cleared, and the distribution feeder and laterals will continue to supply customers.

3.3.3.2 Recloser-Fuse Coordination

If the fault is permanent and not cleared by the recloser interrupts, it is undesirable to shut down the entire feeder and laterals. For this reason, each of the laterals contains a fuse (F_L) that is carefully sized to coordinate with the recloser operation. If the fault is temporary, the recloser interrupt will enable the arc to extinguish and the system to return to normal without any fuses blowing. But if the fault is permanent, the appropriate distribution lateral fuse will blow during the recloser cycling before the recloser gives up on the third try and locks open. Thus, the setting of the recloser operation and the sizing of distribution lateral fuses are critical. This is known as coordination.

When the correct fuse link sizes are used in the system, no fuse will be blown or even damaged by a temporary fault beyond it. That means that the recloser will open the circuit at the substation or on the system one, two, or three times without the fuse links being damaged. However, if the fault is permanent, the first fuse on the source side of the fault will blow during the recloser attempts and isolate the distribution lateral with the permanent fault. This is the hallmark of proper distribution circuit reliability planning. Another concern is that voltage adjustment devices may need to be retuned if substantial DG inputs are added downstream, thereby increasing applicable customer voltages by reducing feeder or lateral voltage drops.

3.3.4 Fuel Cell Inverter Relationship

If any significant DG systems were to continue injecting power into the laterals and distribution feeder circuit during recloser openings or fault-clearing attempts, those generators would contribute to a low recloser reading of fault currents and combine with the reclosed current to upset the fuse link timing. If this were the only issue, a handful of scattered 5-kW RFC power plants would be unlikely to represent a serious problem. However, if DG has been fostered to materially improve a distribution line's capability and has been successful in adding significant capacity to a distribution feeder, then a much more complex coordination timing will need to be managed.

For the safety of co-op personnel and other customers on the grid, it is critical to prevent islanding. Islanding can occur when one or more RFCs on a distribution lateral continue to operate and energize that portion of the grid after the related fuse, F_L or F_T , has opened because of a fault or been opened by co-op personnel attempting to service the distribution system. Thus, in the event of a recloser operation or system or line outage, an RFC power plant must cease providing power to the system, wait a suitable time after the system returns to normal, and then resume if the mode of operation has been set to grid-parallel.

Fortunately, because the RFC power plant produces AC power by means of a non-inertial static power converter—in effect a DC-to-AC inverter—the RFC power plant reaction to a grid upset can be essentially instantaneous. This does not mean the unit needs to disconnect from the grid, only that the inverter must stop operating when the grid voltage disappears and must not return to operation until the grid returns to normal after an outage or recloser operation.

3.3.5 Residential Fuel Cell Demonstration Grid Example

Figure 16 shows the electrical interconnect grid for the Fort Jackson RFC in the CRN demonstration program. Similar to the typical co-op grid, this radial grid is fed on one end by a single substation. The fuel cell installation is on a two-wire, single-phase circuit with the interconnect point 2,100 ft from the substation. The radial extends an additional 1,500 ft beyond the RFC location.

As shown in Figure 16, the fuel cell interconnect tie with the grid is at a 37.5-kVA pole transformer serving three homes. Each of the dwellings has a heat pump, but they have gas cooking and water heating. As a result, the average annual load of each of the homes is estimated at 2.1 kW, with 6.3 kW of average use among the homes. The homes' estimated peak 15-min demand is 6.8 kW, with a resulting maximum draw on the transformer of 23.5 kW.

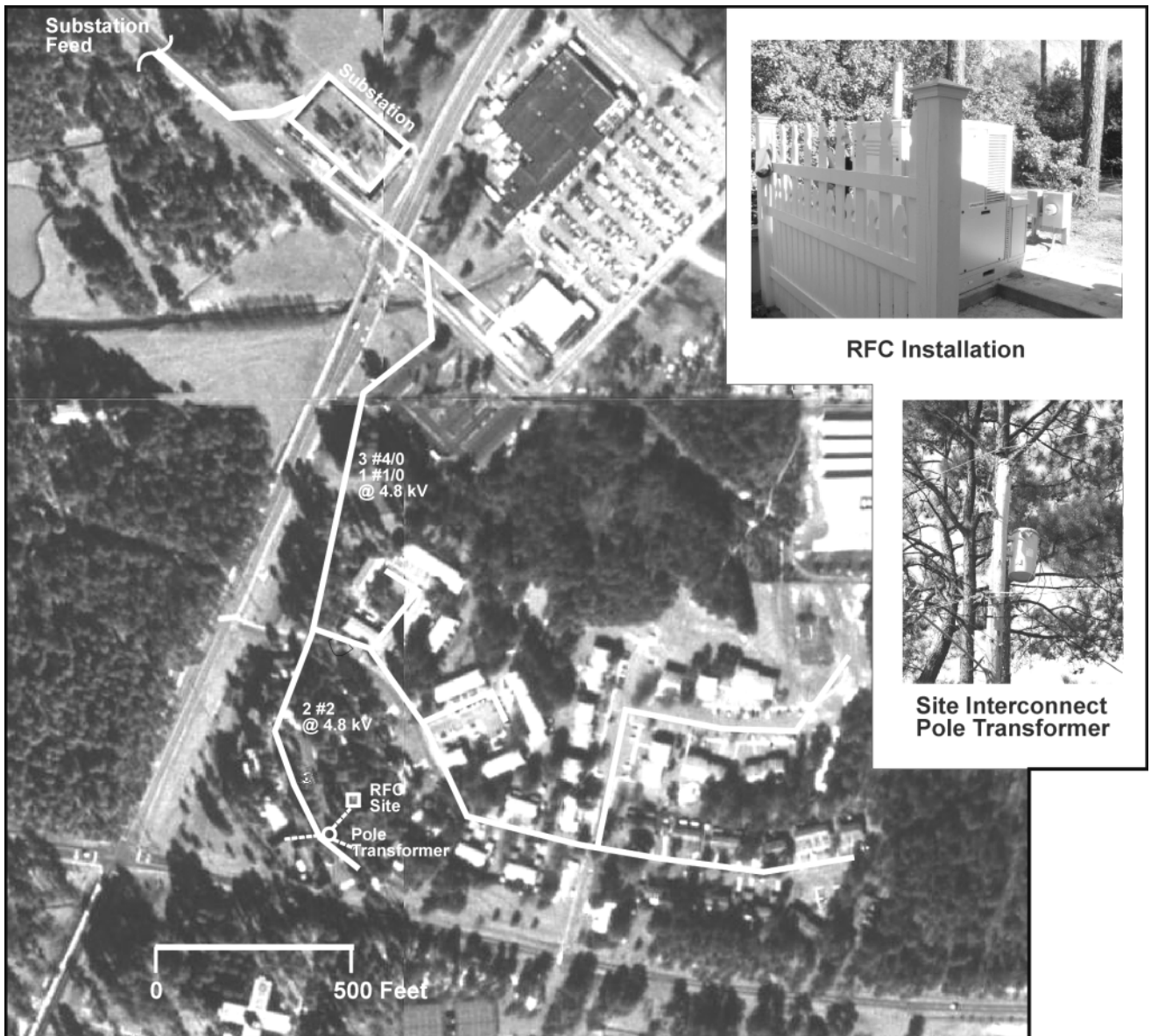

Figure 16. Residential grid configuration at Fort Jackson, South Carolina

This fuel cell is CSA-certified and, thus, meets 1547-type guidelines. It operates as a dual-mode critical load unit and when in grid-parallel mode has a dispatch setting from 2.5–5 kW. Because residential load profiles tend to be highly variable, there are likely some nighttime periods when the fuel cell exports power back to the grid and, given that the grid is “normal,” even into other dwellings on the secondary side of the transformer. Based on the fuel cell’s certifications and favorable demonstration at other sites, no anti-export or redundant protective relaying were judged to be necessary or have been required at this site.

3.4 Residential Fuel Cell Electrical Interconnect

The RFC electrical interconnect and metering diagram in Figure 17 shows a typical configuration for RFCs in the CRN demonstration program. The inverter has a 120-V AC output, rather than 120/240, which may become typical for power plants in the 5-kW range. One reason may be that there is little 240-V work at the 5-kW level that could be done in a normal dwelling by an RFC.

As pointed out in the market section of this report, after the deduction of any electric water heater load destined for fuel cell thermal recovery, 80% of residences have an electric use of less than 1.6 kW on an average annual basis. However, that belies a great deal of diversity between day and night loads and loads from minute to minute during daytime high-use periods. For example, a gas furnace and blower would only be around 0.6 kW at 110 V. In contrast, 240-V loads are generally quite large. For example, a single burner on a kitchen electric range is 1–2.5 kW, and a clothes dryer is 5 kW. A 3-ton heat pump or central air conditioning unit has a 4.8-kW run load and a start load of 11.5 kW, even after the addition of a soft-start controller.

Given the magnitudes of typical 240-V loads, few if any can be supported by a 5-kW RFC, even with extended, battery-supplied inverter head room. Thus, unless things change appreciably in a future RFC mature market or it becomes more cost-effective to build 120/240-V RFC inverters than 120-V inverters, there does not seem to be much reason for 120/240-V fuel cell output for residences. A related issue, of course, is what loads a normal grid-parallel fuel cell purchaser would reasonably wish to supply in the event of a grid outage (e.g., light, refrigeration, gas furnace, small home office, a television). These loads should be within reach of a 5-kW, 110-V RFC.

Moreover, because 5 kW only represent four load panel household circuits, it is doubtful that the resulting 120-to-120 service line load balance would be materially different from what currently exists in a normal dwelling. In any event, even if the above interconnect were to change to 120/240 V, the basic circuit would remain the same, with the inclusion of another set of hot leads through all the needed contactors, breakers, and disconnects. As shown in Figure 17's upper insert, the basic fuel cell circuit consists of a main contactor or motorized circuit breaker labeled "Fuel Cell." This connects the fuel cell to all external loads.

Under normal dual-mode grid-parallel operation, both the "Critical Load" and "Grid" contactors are closed, with both circuits being supplied. In the event of a grid upset, the "Grid" contactor would open, and the fuel cell would reconfigure itself to supply grid-independent power only to the "Critical Load" contactor. When the grid returns to normal, the steps are reversed, and the unit reconnects to the grid. If the fuel cell has a shutdown, the "Fuel Cell" breaker opens, but the two downstream contactors remain closed. In this event, the residence's critical load is supplied by grid power backflowing through the "Grid" contactor and then out through the still-closed "Critical Load" contactor.

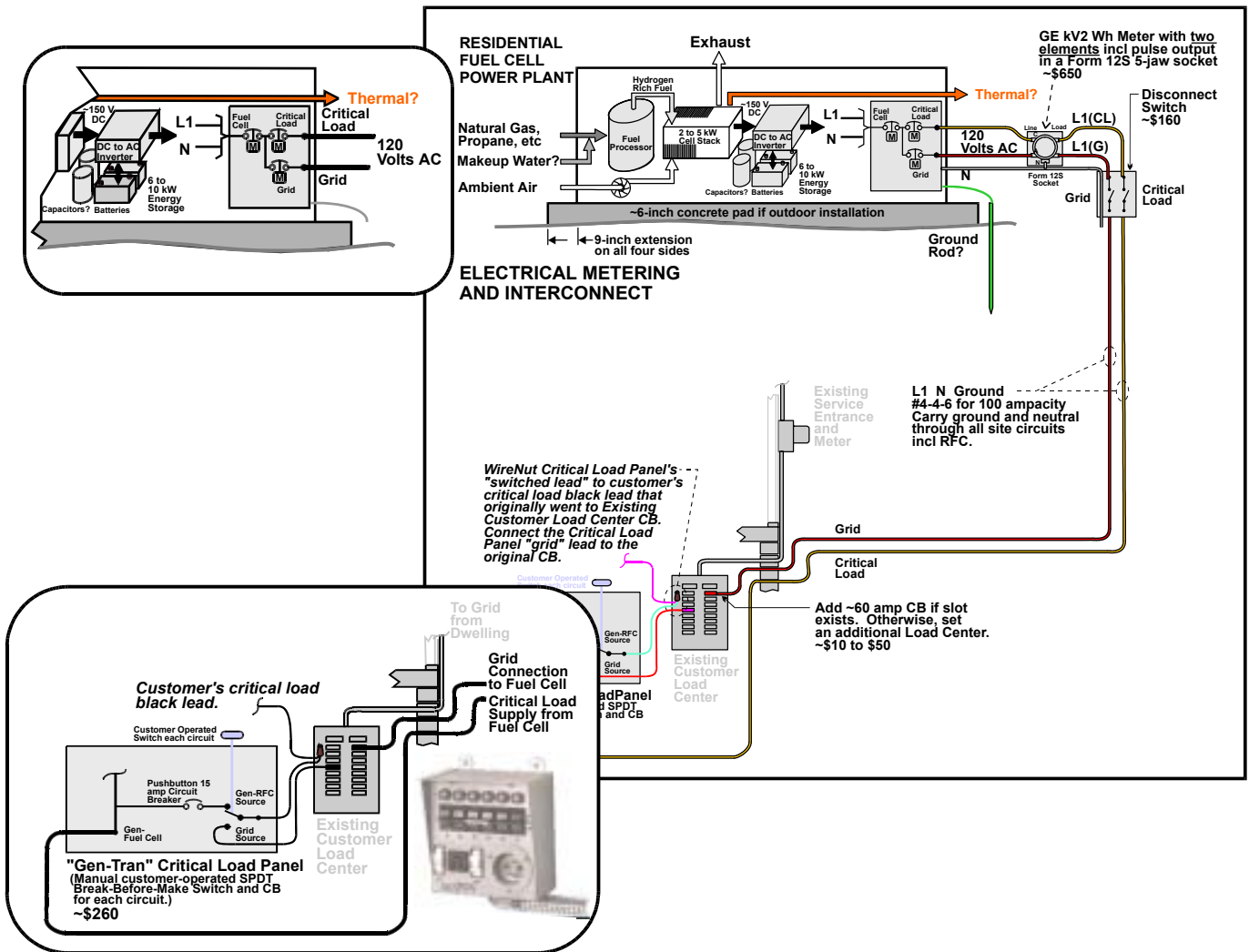

Figure 17. Residential fuel cell electrical interconnect and metering

Because the interconnect has two 120-V outputs, one of which is the grid and can flow in either direction, a two-element electric meter is needed to correctly measure electric production from the unit. The fuel cell disconnect switch is actually a bit more complex than shown. It is a double-pole, double-throw (DPDT) center off switch. The up or normal position connects the fuel cell to both the grid and critical loads. The center off position is an emergency disconnect position that isolates the fuel cell from the grid and everything else. The down position is for fuel cell service. It isolates the fuel cell from the grid but connects the critical load to grid supply.

RFC interconnect with the grid is accomplished by adding a 60-A circuit breaker to an unused slot in the dwelling's existing customer load center, as shown in the lower insert. If there is no open slot, then a new main lug panel is set between the dwelling's service entrance and the load center. In that case, one circuit breaker in the main lug panel feeds the existing load center, and the other breaker in the lug panel ties to the fuel cell.

Although the manufacturer recommends setting a new critical load panel, that implementation has been found to be expensive and labor-intensive. Moreover, the customer has no flexibility after the new panel is installed in allocating loads to normal or critical status. Moreover, in the event the “Critical Load” contactor in the fuel cell power plant fails to operate, the customer is left without critical load power unless he goes outdoors and throws the DPDT disconnect switch to the down position. Customers find this intimidating, and it has the added disadvantage of leaving the fuel cell without cabinet power.

A better option has been discovered through the CRN RFC demonstration program. This uses a code-approved GenTran switch that can be installed easily in less than an hour and is cheaper overall. Installation consists of wire-nutting the black-paired lead to the critical load wire and the companion red lead to the associated circuit breaker. Loads can be selected from either 120-V side. Moreover, the GenTran comes with small watt (amp) meters and the critical load circuit breakers built in. Thus, the customer can select up to six or eight potentially critical loads. These can be individually selected or moved at any time by flipping switches up or down on the GenTran panel, even when the fuel cell is supplying critical loads during a grid outage. An additional benefit is that if the fuel cell shuts down and fails to transfer the critical load to the grid, all the customer has to do to restore power to the critical load is go to the dwelling’s own load center and flip all the GenTran switches to the down grid-connect position.

Alternate Configuration to a DPDT-CenterOff Interconnect Switch:

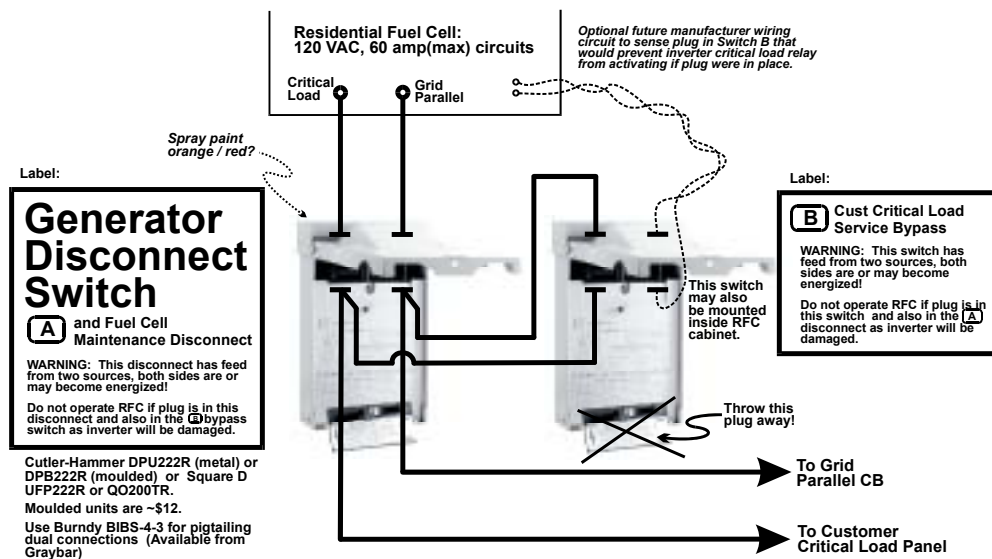

Figure 18. Alternate disconnect for RFC grid interconnect service

In addition to the GenTran panel, other efforts are under way within the CRN RFC demonstration program to reduce the high installation costs described in Table 1. One option is to replace the \$160 DPDT disconnect switch, which is expensive both to buy and install. An added factor affirmed by demonstration experience is that anything in a fuel cell installation that looks “different” from an ordinary heat pump or water heater tends to drive up bid and installation costs as electricians and plumbers grapple with uncertainty. One concept is to replace the expensive DPDT disconnect switch with two new \$12 pullout disconnects for air conditioners that are also approved for service entrance application. Concurrently, to avoid the cost of a pedestal or exterior wall mounting, the assembly would be mounted directly on the power plant. A close proxy for such direct switch mounting already exists in the Carrier 48GS series, a residential combination gas furnace and 5-ton central air-conditioning unit for outdoor pad location. This unit has essentially the same electrical and fuel input sizes as a 5-kW RFC.

3.5 Fuel Cell Grid Interconnect Experience

3.5.1 Residential Fuel Cell Program

The RFC at the Fort Jackson residence is a dual-mode unit that normally operates in grid-parallel mode with a preset dispatch level of 2.5–5 kWd. This Plug Power unit also supports a grid-independent critical load. In this installation, the critical load is supplied via dwelling circuits rewired to a separate supplemental load panel and principally powers kitchen and home office loads. The unit was commissioned in February 2003 and has interfaced with the grid for several thousand hours without any grid interconnect incidents.

Indeed, the only grid interconnect happening of note is the following experience of the fuel cell service person:

“I received a call from Col. -----'s wife yesterday saying (in a semi-frantic tone) that something ‘strange’ was going on with their power. I could hear Col. ----- in the background. Some things were on, and some things were not. They assumed the fuel cell was causing problems. Before I could get ready to head out there, I got another call from them. Seems that the next-door colonel's wife had popped in to say they had no power. Then ‘the light comes on’ in their heads that everyone in the community is without power except the -----s, who still have their refrigerator, kitchen lights, computer, and TV on. Power was off for about an hour.”

This site’s favorable grid interconnect experience is consistent with those of more than 125 similar RFC sites across the country. These units, operating in 18 states, have already demonstrated more than 1.1 million hours of equally successful experience in following proper grid-parallel interconnect procedures.

3.5.2 PC25 200-kW Phosphoric Acid Fuel Cell Proxy

Another example of effective grid-interactive design is the commercially available 200-kW ONSI phosphoric acid fuel cell, which has worked successfully and without incident through thousands of grid upsets and more than 6.3 million hours on electric grids throughout the United States and world.

Figure 19 shows a typical interconnect event for an ONSI 200-kW fuel cell used at the Pittsburgh International Airport. This demonstration was a joint effort of the local gas and electric utilities and demonstrated a 480-V, three-phase DG application on the local grid.

The digital fault recorder shows the fuel cell inverter's successful response to a local grid upset, shown by the arrow on the chart in the grid voltage panel. Within a fraction of a cycle, the fuel cell current output has interrupted, as shown by the fuel cell current output panel. This means that the inverter essentially stopped operation and power export. The residual small current waveform during the interrupt from the 490 to 700 ms time markers reflects the connection of the fuel cell's outboard magnetics and filters because the unit is still physically connected to the grid even though the inverter has stopped producing power. The interruption of power output to the grid is also confirmed by the decline in cell stack amps because the stack DC output is now being dumped into an onboard load resistor rather than into the inverter that has stopped operating.

The grid returns to normal at about 530 ms, and the inverter controls continue to watch the grid for stability. The grid continues to be stable, and at 800 ms, the inverter resumes dispatch, as evidenced by the returned current waveforms of the fuel cell current output. These are the AC current flows on Phase A, Phase B, and Phase C to that site's 480-V grid interconnect transformer. If the grid upset had continued for more than 20 seconds, the fuel cell would have opened its grid interconnect breaker and, upon confirmation that the breaker was open, converted to a grid-independent operation to power an isolated critical load. If that had been the case, the fuel cell would have continued to power the isolated critical load until the grid reliably returned to normal. At that point, if the software permissions had been selected by the customer or grid, the unit would then have automatically changed over and resumed grid dispatch.

As the chart emphasizes, a fuel cell inverter—whether for a 200-kW industrial fuel cell or a 5-kW residential unit—can have an instantaneous response to a grid upset and can therefore instantly stop export power reliably until a grid upset or fault clears. Moreover, because the inverter can accurately distinguish between normal and upset grid conditions and the interrupt can be essentially instantaneous, it is not necessarily required that fuel cell units go off the grid for extensive periods while reclosers are active. If the recloser sees an abnormal condition, so will the fuel cell, and it will again stop grid-parallel operation.

Typical Fuel Cell Inverter Interrupt Response to Grid Voltage Disturbance . . .

Records from Fuel Cell Power Plant Controller's Own Grid Event Logs

Date	Time	Project Time		FCGridLog
		Clock	Sec	
7/15/94	9:22:07 AM	8,831.42	0	inv Bridge 1 pole overcurrent
7/16/94	10:01:39 AM	8,856.08	0	inv Bridge 1 pole overcurrent
7/17/94	4:34:55 PM	8,886.63	0	inv Bridge 2 pole overcurrent
7/19/94	4:08:31 PM	8,934.19		GRIDOK flag disabled
7/19/94	4:08:46 PM		15	GRIDOK flag enabled
7/20/94	6:57:31 AM	8,949.01	0	inv Bridge 1 pole overcurrent
7/21/94	6:08:36 AM	8,972.19	0	inv Bridge 2 pole overcurrent
7/25/94	3:24:19 AM	9,065.46		inv Bridge 1 pole overcurrent
7/25/94	3:24:20 AM		1	GRIDOK flag disabled
7/25/94	3:24:35 AM		16	GRIDOK flag enabled
7/28/94	8:26:48 AM	9,142.50	0	inv Bridge 1 pole overcurrent
7/29/94	7:47:54 PM	9,177.85		GRIDOK flag disabled

TYPICAL GRID FAULT

TYPICAL CONTROLLER TIMED GRID EVENT

TYPICAL GRID CAPACITOR SWITCHING

Electric Utility Digital Fault Recorder Log at Fuel Cell Interconnect

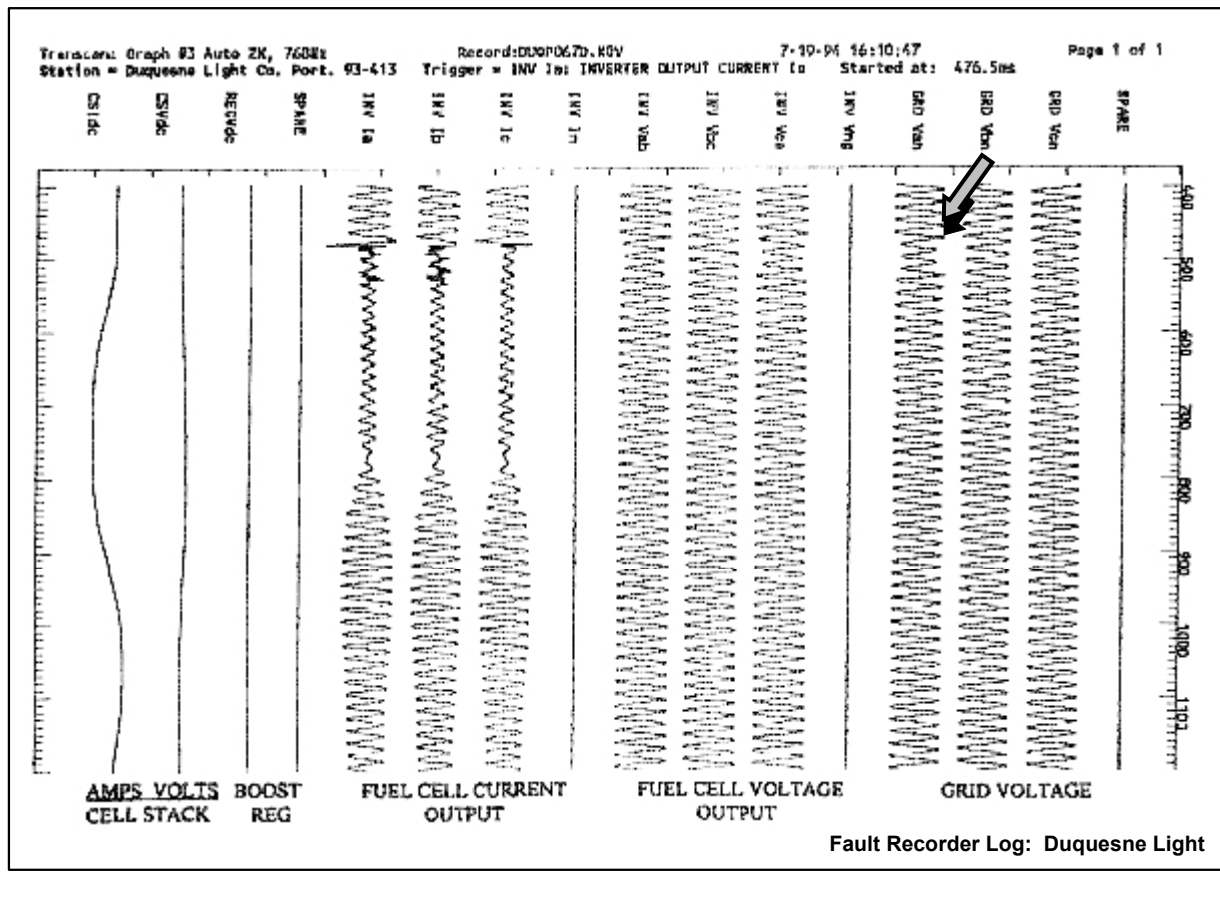

Figure 19. 200-kW fuel cell interconnect experience

The ONSI 200-kW fuel cell, designed well before 1547 and related interconnect guidelines, clearly demonstrates that manufacturers can design highly successful grid interconnection procedures and protocols. These 200-kW fuel cells have successfully interacted with grids worldwide for 6.3 million hours without grid interconnect incident. Moreover, except for a few instances of extraneous anti-export relaying that clearly defeat the purpose of DG anyway, none of the many installations on U.S. grids has ultimately been required to have redundant electric utility interconnect anti-islanding relaying on top of the equivalent software functions already embedded in the power plant inverter.

Concurrently, it is important that an RFC have the capability, and permission, to disconnect itself and the customer dwelling, or at least related critical load, from the grid in the event of a prolonged grid upset so the fuel cell and customer dwelling can operate in an emergency in a safely disconnected, grid-independent mode. Obviously, any RFC will be a major expenditure, and a key market value to be derived from that purchase will be power supply security in the event of a grid outage. Moreover, it is important that an RFC have permission to reconnect to the grid when the situation has returned to normal after a short wait to ensure that any recloser fault-clearing events are not still under way.

3.6 Dispatch Concepts

3.6.1 Basic Operation

From a practical point of view and considering likely customers, two basic types of RFC markets will exist in the foreseeable future. One market is for grid-independent remote applications. These are customer sites at which the electric grid is not available or cannot be economically reached because of single-phase line extension costs (which range \$10,000–\$30,000/mile). Even where distances are reasonable, a compounding factor is that it can be extremely difficult, if not impossible, to secure electric service line extension rights-of-way from adjacent property owners and federal agencies such as the Forest Service and the Bureau of Land Management.

A second type of residential market is for dual-mode units. These units normally run in grid-parallel mode, but in the case of a grid outage or upset, they can convert to grid-independent operation to supply at least some of the customer's electric needs. The transfer is unlikely to be an instantaneous uninterruptible power supply-type switching but will rather take a few seconds. The intent of this flexibility is to power customer-designated critical loads during a grid outage. Examples of critical loads include a gas furnace, a refrigerator, a well pump, lighting, and perhaps a home office. An example of this type of grid interconnect is illustrated in Figure 17.

Even though 80% of residential dwellings have average annual loads less than 1.6 kW, typical hourly loads during daytime periods can easily reach upwards of 3 kW, with 15-minute demands of 5–8 kW or more for homes with central heat pump or air-conditioning units. Indeed, motor-start loads lasting one-half second can reach upwards of 20 kW for such compressors unless special soft-start controllers are retrofitted.

Unlike engine-generators, fuel cell inverters have no rotational inertia and are instantaneous current-limited. Reasonable headroom is usually designed into RFC inverters, and some level of battery or capacitor energy storage is likely built into remote or dual-mode units. Nonetheless, the ability of either a remote or dual-mode grid-independent RFC to support 240-V appliances or heating-cooling central units will likely be minimal, unless, of course, the customer wants to spend thousands of dollars for a significantly oversized fuel cell unit.

For DG to achieve its potential, RFCs need to interface with the grid in some manner. For example, even if the residence's fuel cell does nothing more than load-follow the customer's hourly electric use, it offsets a like amount of grid generation demand. On the other hand, if the unit is producing a constant power level such as the 2.5–5 kW of the Fort Jackson unit, then some power is being exported from the customer's dwelling at least part of the time. At that particular site for certain periods at night when the heat pump is not running, power is likely exported to the other two homes on the secondary side of the power transformer and most likely even back to the grid.

It is important to note that there have been no interconnect issues or problems with the operation of the RFC at that site. Nonetheless, there exists the underlying question of what the optimum mode and output level of DG operation is for the customer and the grid.

3.6.2 Co-Op Input

A complementary goal of the grid interconnection effort within the CRN RFC demonstration program is to advance DG as a power supply for electric co-ops. For this reason, CRN RFC users group participants have been surveyed to determine the preferred protocols for RFC use as grid-supplemental generation.

This co-op survey extensively covered a number of elements, including:

- Co-op product marketing experience and capabilities
- Service line extension experience and costs
- Residential remote applications including size and present customer systems
- Nonresidential remote power applications
- Desired features for remote application RFCs
- Probable applications as a function of fuel cell pricing and owning versus renting
- Distribution and service channel options and assessments.

Although all the results are of interest, only the key grid-parallel grid interface portions are highlighted in Figure 20. The top three bars indicate that only about one-half of the co-ops felt that grid-parallel RFCs had to be large enough to power a residence's heat pump or central air conditioner. Sixty percent agreed or strongly agreed that the unit should be big enough to run the remaining residence portion of the site's electrical load. Only 20% disagreed with the concept that it is OK to export power to the grid during daytime.

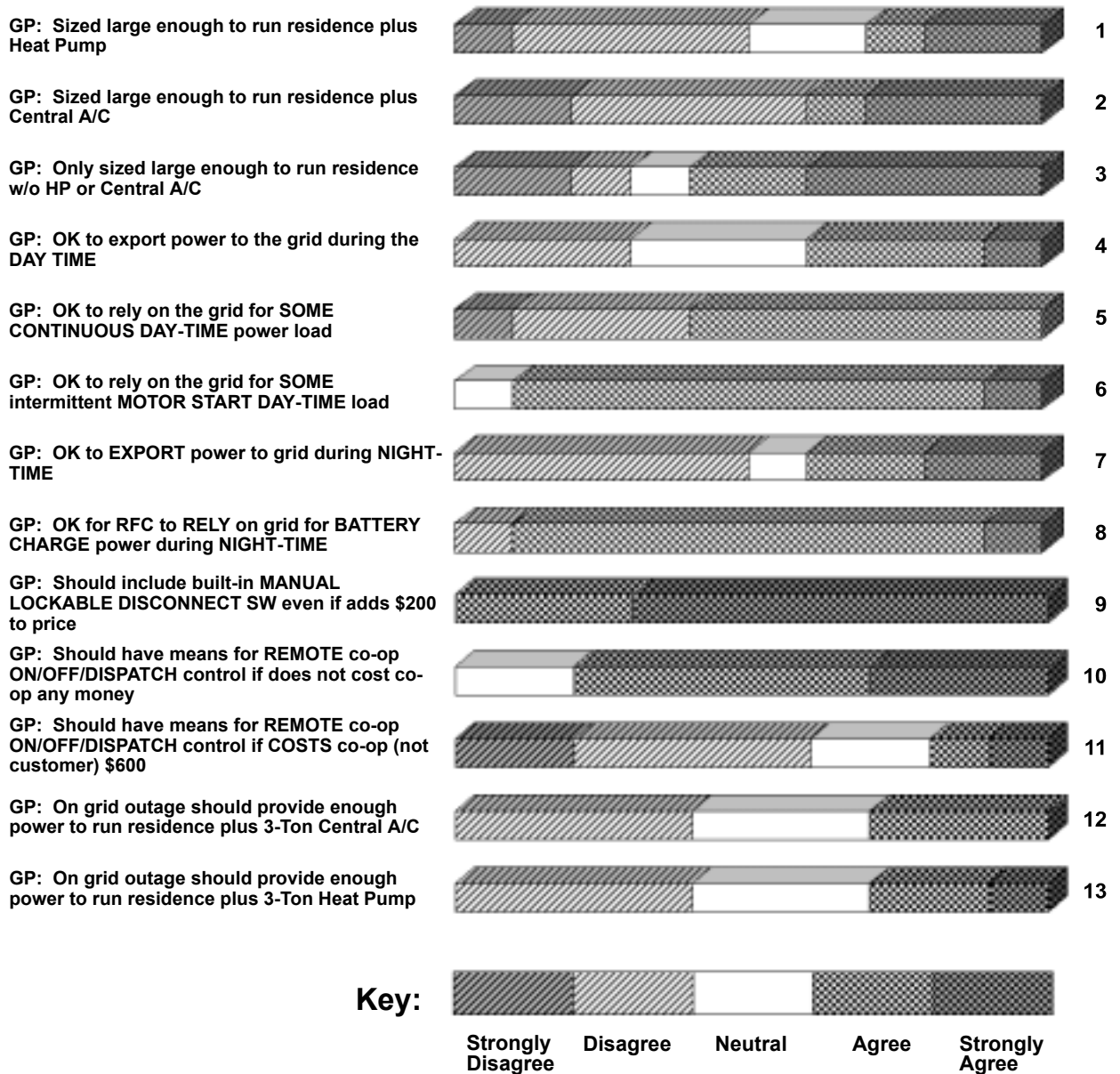

Figure 20. Co-op portion of survey results related to grid-parallel RFC applications

Bars 5–8 examine preferred RFC capabilities for exporting or importing grid power. Respondents were equally split on whether it is OK to rely on the grid for some daytime power load. Interestingly, however, 90% did agree or strongly agree that it is OK to rely on the grid for some intermittent motor start daytime load. This may reflect an inherent understanding that fuel cells become more expensive if a 5-kW unit needs to have the inverter headroom, plus the battery and capacitor energy storage, to meet a 20-kW motor start load. Alternately, it may reflect an understanding that motor start loads for such items as a heat pump compressor are very short and highly diverse in terms of grid needs. In any event, this response has an encouraging effect on needed grid-parallel RFC design, particularly if the related dual-mode, grid-independent output during a grid outage or upset is principally seen by consumers as power for lights, furnace blowers, and the like.

A fair difference of opinion existed about whether it should be permissible for a fuel cell to export power to the grid at night. Forty percent agreed or strongly agreed, and 50% disagreed. Night is, of course, a time when grids rarely need power. Interestingly, 90% agreed or strongly agreed that it is OK for RFCs to rely on grid for battery charge power during nighttime. As will be seen later, this type of time-shifting has important implications for RFC applications, particularly when they are fueled with more expensive propane. In most instances, charging a fuel cell's batteries at night from the grid will be more economically attractive than burning propane in the fuel cell unit, or perhaps even natural gas, to produce battery charging power.

Bars 9–11 show the co-ops liked the idea of a lockable manual disconnect switch and a remote dispatch control, providing the latter did not cost the co-op any money. However, when the question of who pays for the dispatch control was reversed, opinions changed significantly. Sixty percent disagreed or strongly disagreed with the statement that RFCs should have means for remote co-op on/off/dispatch control if it costs the co-op (not the customer) \$600.

The last two bars address whether the RFC should be able to operate a 3-ton central air conditioner or heat pump during a grid outage. Thirty percent thought a fuel cell should have that capability, but 40% disagreed that such a feature is necessary. In the end, this will be settled by a mix of manufacturer catalog selection and pricing and consumer willingness to pay for some 5 kW of running and 12 kW of motor-starting fuel cell capacity to operate a 3-ton compressor during a grid outage. This particular design consideration merits attention by manufacturer or industry consumer focus groups.

3.6.3 Grid Import-Export-Dispatch Analysis

Based on prospective market-entry RFC specifications, grid-parallel units are likely to be capable of clock-controlled dispatch. However, the fuel cell and grid will almost certainly have different cost profiles. In turn, the resulting economics will feed back to prospective consumers and affect the amount of DG prospectively available for grid use. Given the potential co-op interest in RFCs and associated grid-parallel DG, an analysis of potential dispatch outcomes is needed and timely.

Calculating the import and export power of an RFC residence is a complex undertaking. The amount of power imported or exported from the fuel cell installation depends on the fuel cell output and the dwelling's electric use. Moreover, the fuel cell will likely have some flexibility in power output and type of dispatch. These could range from a simple constant output to a complex load-following of the dwelling's load. Thus, a number of factors need to be known, not the least of which is the customer's hourly electric use.

CRN has developed a useful proprietary program called LoadShape for the design of substations and feeders. The tool overlays user-selectable curves encompassing the equivalent of a year's kilowatt-hour consumption and kilowatt demand data. In late 1997, this CRN-EPRI undertaking provided electric co-ops with important load profile data from EPRI's Center for Electric End-Use Data. The result is a CD-based library of load profiles constructed from a statistically broad base of actual metered sites. The CD contains more than 1,000 annual load shapes for residential, commercial, and industrial customers. More than two dozen of these segments also include hourly weather-adjusted data for 20 typical cities serviced by CRN members.

Because of the way the LoadShape tool was developed, it is possible to use reported statistical variances to disaggregate the kilowatt demand data, reported for a composite of 10 dwellings, back to the meter of a single typical dwelling. Moreover, because of the way the curves are reported, it is also possible to extract an electric water-heating curve from the other residential profiles to determine the electric water heating kilowatt-hours that would have been converted to thermal recovery in an RFC application.

A fuel cell power plant also has potential flexibility that can affect customer economics. For example, a fuel cell could be set to run at a 0.5 kW during the night and 4 kW during the day, when both grid and customer loads are high. Another option is to run the fuel cell in a load-following mode during portions of the day so the unit matches the dwelling load and, therefore, neither imports nor exports power. An added complexity is that fuel cells will not necessarily have the same efficiency and fuel use per kilowatt-hour at all power levels. For example, PEM fuel processors will generally be less efficient at low loads, and inverters will likely change DC-to-AC efficiency over various power levels. Moreover, all fuel cell power plants will have fans, blowers, and pumps that represent a relatively constant parasitic power deduction. This tare power load can considerably affect efficiency and resulting heat rates at idle or low dispatch levels.

In addition, the analysis needs to examine dispatch economics for both the customer and grid, which will have different costs. For example, grid costs are likely to be different between on-peak and off-peak periods; the customer's own electric rate schedule may be, too. Thus, a number of complexities need to be taken into account within the analysis and its inputs. The Dispatch and Export-Import Calcs software program is shown in Figure 21.

CRN RFC Demonstration Tool Kit: Dispatch and Export-Import Calcs.xls

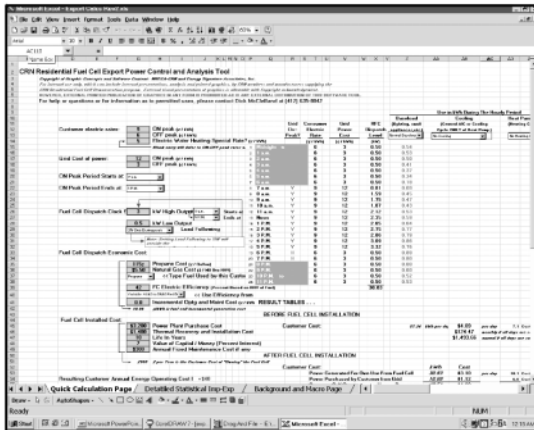

Atlanta Heat Pump: RFC Set at
3 kW On-Peak 0.5 kW Off-Peak

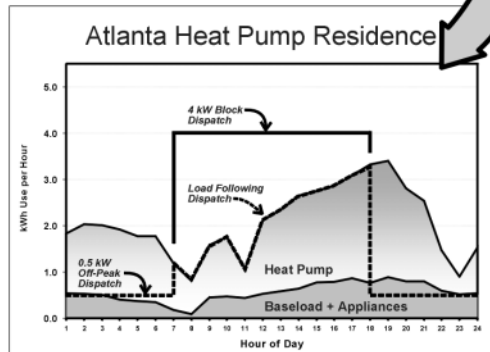

24 Data Points = 23.6 kWh/D Export 15.0 kWh/D Import

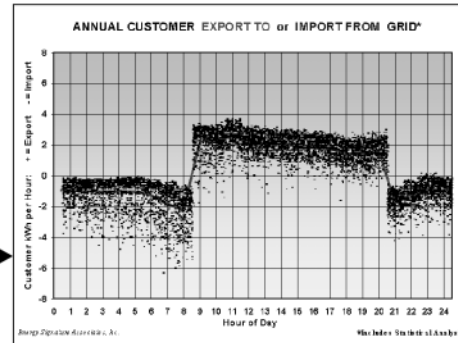

Full Year: Includes 3 day types within 12 month types
8760 Data Points = 23.7 kWh/D Export 15.1 kWh/D Import
CRN LoadShape

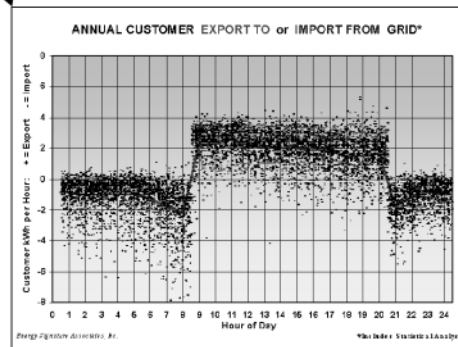

Statistical Variation Overlay (Monte Carlo Simulation):
8760 Data Points = 24.5 kWh/D Export 15.9 kWh/D Import
CRN LoadShape

Figure 21. RFC dispatch and export-import calculation program

The basic spreadsheet for analyzing the effect of scheduling specific dispatch curves to operate the RFC in parallel with the grid has the following input options:

- **Overall customer use profile**
 - Normal baseload appliance profile
 - Central air-conditioning profile
 - Columbus average annual
 - Columbus hottest month (August)
 - Atlanta average annual
 - Atlanta hottest month (July)
 - Heat pump heating profile only
 - Columbus coldest month (January)
 - Atlanta coldest month (January)
 - Heat pump heating and cooling profile
 - Columbus annual average
 - Atlanta annual average
 - Additional user-defined 24-hour profile
- **Whether dwelling had an electric water heater before the fuel cell was installed**
- **Start and end time for grid on-peak period, customer electric rates for on-peak and off-peak, and any special electric water-heater rate if applicable**
- **Grid electric supply applicable purchase cost including on-peak and off-peak**
- **Fuel cell day and night dispatch levels with fuel cell daytime dispatch start and end times**

These may be specific levels such as 0.5 or 3.5 kW or may be load-following. Load-following may be selected for only the day dispatch period or for all 24 hours. The latter selection will emulate a remote grid-independent residence.
- **Propane and natural gas fuel costs**
- **Fuel cell electric efficiency average or a user-entered composite build curve of fuel cell efficiency versus dispatch level**

In the second case, the user enters dispatch points with companion fuel processor, cell stack, and inverter efficiencies and tare power parasitic loads. The program will then automatically calculate the overall power plant efficiency by dispatch level and construct a look-up curve that will be used to predict actual fuel cell efficiency for each hour's dispatch level. Suggested data are provided for both PEM and SOx units.
- **Incremental operating and maintenance costs (if any)**
- **Fuel cell installed cost including buildup from purchase cost, thermal recovery and installation cost, life of unit in years, value of capital, and annual fixed maintenance cost**
- **Reimbursement of export power to customer, including none, net metering at customer rate schedule, reimbursement at grid on-peak and off-peak costs, and reimbursement at customer's actual cost**

The program will then build the composite load and dispatch curves and generate a graph of the customer's hourly load curve segments and fuel cell dispatch levels. This will automatically calculate the following outputs:

- Hourly self-generation, grid import, and grid export power plus total daily levels of all three power types including grid import and grid export separated by on- and off-peak periods
- Customer cost profiles, including daily results of kilowatt-hours, daily cost in dollars, and cents per kilowatt-hour with and without the fuel cell. Also calculated will be monthly and annual operating costs, as well as the daily, monthly, and annual cost for the fuel cell if it were only operated in a load-following, grid-independent mode. Also calculated will be the customer's total annual and net operating and owing costs for the fuel cell, including power plant purchase and installation
- Supplemental companion pages generate 8,760 hourly annual import-export data calculations with and without a Monte Carlo statistical overlay that uses reported data coefficient of variation levels. Also provided is a composite hour-of-day export-import scatter graph that includes a recalculate simulation tool.

The second portion of the program generates statistical data for 8,760 data points over a year and has validated that easy-to-use, 24-hour average annual curves yield accurate annual results. The two right graphs in Figure 21 display hour-by-hour simulations for the year and are graphed with and without a Monte Carlo statistical overlay using the field-measured kilowatt-hour coefficient of variation. As demonstrated by the daily summaries, the single 24-hour substitution is in excellent agreement with the full, but more cumbersome, 8,760-hour calculations.

Thus, because only average hourly annual data need to be used to produce accurate results, the CRN RFC demonstration tool kit's dispatch and export-import calculations combine both power and ease of use. Only average annual profiles need to be set by toggle selection boxes on its first page. Moreover, because the rates and dispatch times/levels/types can be readily changed, instant feedback is provided to the user about resulting customer and grid benefits. The user gains a quick, intuitive understanding of the types and levels of dispatches that will make sense to the grid and the customer for RFC DG applications.

An example of dispatch calculations for a large Southern residence with a grid-parallel RFC installation is presented in Figure 22. The site initially had an electric water heater before fuel cell thermal recovery and uses a heat pump for heating and cooling. The additional rate and grid information illustrates the program's flexibility because all tabular data can be instantly changed by the program user. Although the data used in this example are intended to be representative of the types and levels of prospective inputs, the fuel cell application and installation elements are typical of prospective target levels for a mature RFC market product. The 30% efficiency denotes a PEM fuel cell.

The curves on the graph represent the customer cost of operating the RFC at the tabulated dispatch profiles using either natural gas or propane. In effect, the costs shown are equivalent to the following salient DG assessment protocol:

“Assume that the customer already owns a residential fuel cell that has been purchased principally to supply needed power to his residence and home office in the event of a grid outage from a hurricane or ice storm. The fuel cell is a dual-mode unit and can also run in a grid-parallel configuration with the local electric grid, which is interested in receiving power from the fuel cell in order to assist the region’s electric supply and/or in receiving other DG benefits. Given the above, what would various dispatch options cost the customer relative to not running the fuel cell at all and saving it for emergency use only?”

Large Southern Heat Pump Residence:

Customer Rate:
On-Peak: 9 ¢/kWh
 7 a.m. to 6 p.m.
Off-Peak: 6 ¢
EWH: 5 ¢

Grid Cost:
On-Peak: 12 ¢/kWh
 7 a.m. to 6 p.m.
Off-Peak: 3 ¢

RFC:
Efficiency 30 %HHV
Propane 110 ¢/Gallon
Nat Gas \$5.50 /MM Btu
O&M 1 ¢/kWh
Inst Cost \$5,500 Total
 7 Yr
 10 %

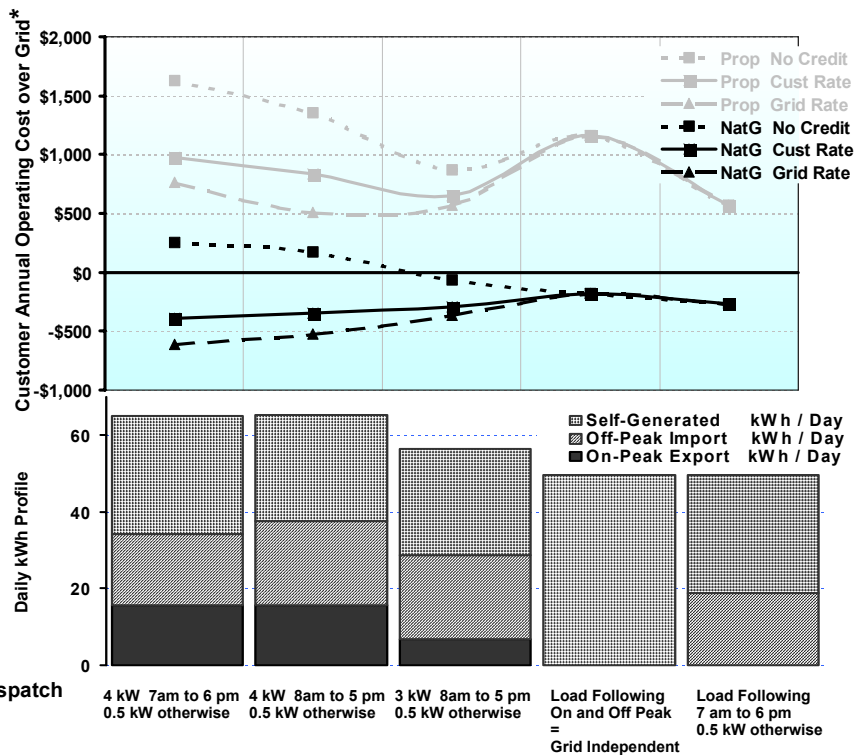

*Excludes RFC Owning Cost which adds and additional \$1,130 per year

Figure 22. Grid dispatch modes, customer economics, and resulting export power

For natural gas, the results show it is generally to the customer’s advantage to run the fuel cell as a DG supply to the grid. A 4-kW dispatch during peak periods with a turndown to 0.5 kW during off-peak periods makes particular sense. This assumes net metering is available at least during peak periods. During off-peak periods, the fuel cell is turned down to an assumed lowest operating level of 0.5 kW because the customer’s \$0.06 off-peak power rate is less expensive than that of power produced by the fuel cell. This night mode is also consistent with the survey response in that co-ops felt it was perfectly acceptable for an RFC DG site to draw off-peak power for customer and battery-charging use.

The bottom bars on the graph depict dispatch options and the power that would be self-generation by the customer for his site loads, off-peak import from the grid, and on-peak export to the grid. The power available to the grid would be power that the customer did not purchase because of self-generation plus on-peak export power from the customer to the grid. Although other bars are not shown because of their negligible amounts in this illustration, the program also calculates on-peak import from the grid and off-peak export to the grid. Given that on-peak net metering is available, the most advantageous dispatch mode to the customer was actually the 4-kW, 7-a.m.-to-6 p.m. case, which also has the greatest fuel cell production during peak hours.

The upper set of lines, for a propane-fueled PEM fuel cell, reveal no cases in which the customer could have saved money by running an installed fuel cell unit. This is because the high fuel cost of propane couples with PEM fuel cell efficiency to generate high fuel cell bussbar costs relative to the customer's electric rates. However, if the fuel cell efficiency were increased to the 40% level consistent with solid oxide fuel cells, the resulting fuel efficiency savings would reduce the chart's propane dispatch costs by \$400–\$600. For solid oxide units, this reduction at least moves propane RFCs into the range of being able to potentially operate in a customer-attractive, grid-parallel DG mode.

As typified in the above figures, the CRN RFC demonstration tool kit Dispatch and Export-Import Calcs software has already advanced valuable understandings of what types of DG dispatch are likely to make sense for RFCs in grid-parallel operation. Although not detailed here, related components of this effort have explored the types of internal fuel cell dispatch algorithm software that would be needed for such a DG grid interface.

4 Thermal Recovery

4.1 Importance

The significance of thermal recovery for RFCs transcends energy-efficiency improvements. Economically accomplished, thermal recovery provides energy cost savings offsets that are vital to paying for the fuel cell power plant and its fuel. Unlike electrical interconnects, which are largely the purview of standards-setting agencies and inverter designers, thermal recovery interconnects and their application are instead a complex functional interface between the power plant and site end uses. These factors make thermal recovery and its development more the purview of end-user groups and related efforts, such as the CRN RFC demonstration program. Nonetheless, economic and technical success in the thermal recovery segment is just as critical as success in the electrical interconnect arena.

Typical fuel-to-electric efficiencies for PEM and solid oxide fuel cells are 30% and 40% LHV, respectively. LHV refers to the lower heating value of the fuel and is measured without the thermal contribution from condensing the gaseous water vapor produced by all hydrocarbon fuels. This means that the RFC efficiencies must be multiplied by about 0.90 for natural gas and 0.92 for propane. The exact correction depends on the specific composition of the fuel. Natural gas invariably contains gasses other than methane; commercially sold grades of propane have other fuels than propane present. In any event, these efficiencies mean that a 5-kW PEM fuel cell running at full load year-round consumes around 550 million Btu HHV per year of natural gas. At a half-load of 2.5 kW, the unit would use about 31,600 Btu an hour of fuel. At half-load and \$6/million Btu for natural gas, the fuel bill for an RFC would be \$1,650 annually. For propane at \$1.15/gal at a half-load of 2.5 kW, the fuel bill would be just more than \$3,400. These costs are far from trivial to the customer.

A thermal recovery of 10,000 Btu/hour is equivalent to the electric energy generated by a PEM cell stack running at 2.9 kW. Moreover, if this 10,000 Btu of thermal energy could be recovered from the fuel cell, the actual energy savings credited against the power plant's fuel would be more because of thermal user appliance efficiencies. For example, if this level of fuel cell thermal energy were used to displace gas water heating at 65% efficiency, the effective savings would be 15,400 Btu/hour ($10,000/0.65$). This represents a savings of more than 40% of the power plant's fuel bill for that hour's operation. Alternatively, if the fuel cell thermal recovery could be used to fully substitute for a similar portion of the electric water-heating load at a hotel, for example, at \$0.06/kWh, customer cost savings would have been \$1,540 a year, or almost the entire natural gas bill for the fuel cell.

However, many determinants need to be addressed. What portion of the fuel cell's thermal recovery potential can be reasonably used? Can assurances be found that the annual capital carrying cost of installing such thermal recovery systems does not abrogate the potential annual thermal recovery savings?

The goals of the thermal recovery portion of this CRN demonstration program are to:

- Identify maximum thermal recovery potential from manufacturer RFC units
- Assess likely residential customer thermal recovery uses as well as potential economic and energy savings
- Determine actual thermal recovery performance for residential consumer applications
- Identify and assess key interactions and constraints between the fuel cell power plant and customer thermal uses
- Identify any key code and application issues related to RFC thermal recovery
- Estimate likely residential installation costs and corresponding thermal recovery fuel savings benefits
- Identify and demonstrate concepts and materials to improve thermal recovery potentials and reduce thermal recovery installation costs to market-acceptable levels.

Thus, thermal recovery is more than a way of enhancing energy efficiency for public relations or environmental reasons. These potential fuel offsets indicate why thermal recovery is critical to RFC application acceptance and, therefore, to the technology's potential use as DG. The CRN RFC demonstration program is taking a lead role in assessing these issues and developing essential understandings.

4.2 Thermal Recovery Constraints

4.2.1 Fuel Cell Thermal Output

Typical fuel cell stacks run at about 50% conversion efficiency for processed fuel into DC power, with the balance rejected as heat. Thus, the bulk of the energy available for thermal recovery comes from the RFC's stack. Downstream inverter DC-to-AC conversion efficiencies are generally in the 90%-plus range, with the remaining heat invariably removed by computer-type muffin fans. Although front-end PEM fuel processing could be a potential source for additional thermal Btus, the amount and temperatures are a function of fuel processor design and of ability to provide efficient heat exchange between the feed and product lines as well as into and out of component vessels within this portion of the power plant.

The result is that typical temperatures available to the residence for useful thermal recovery are principally influenced by the cell stack's operating temperature. Given a further allowance for the delta-T across the companion heat exchanger inside the power plant, thermal recovery from PEM units will be less than 170°F and most likely in the 140°F range. For solid oxide units, available thermal recovery temperatures will be at least several hundred degrees hotter than for PEM fuel cells.

4.2.2 Thermal Recovery Temperatures and Safety

Low thermal recovery temperatures pose problems for transferring heat to a usable region for customer needs. For example, hot water for potable uses such as hand washing and showering generally requires temperatures in the 110°F–140°F range. Exit temperatures from space heating furnaces are typically in the 130°F–140°F range, with the exception of heat pumps. Heat pumps, unless the cold ambient temperature supplemental heaters are running, are generally around 80°F–90°F, but these somewhat low forced-air temperatures are often criticized by residence occupants as being too “cool” because of psychometric reasons. Hydronic heating coils and baseboards are generally designed for 180°F inlet water temperatures, and if operated at 140°F, inlet water temperatures need to be expensively oversized by around 80% to compensate for the lost heating capacity of cooler inlet water.

Temperatures that are too high also pose problems. Fuel cell heat exchange temperatures more than 212°F against a water-filled thermal recovery loop would boil the circulating fluid in the customer side of the fuel cell’s heat exchanger if the thermal loop were satisfied or the loop’s circulating pump were to fail. The resulting pressure presents serious scalding and customer safety issues and explains why temperature-pressure relief valves are code-mandated on thermal recovery loops. Even if the several-hundred-degree exhaust from a solid oxide fuel cell were simply ducted into the flue of a conventional gas water heater, the same unsafe condition would exist absent exhaust flow diverter dampers and temperature and pressure (TP) relief valves.

4.2.3 Residence Application Profiles

Thermal recovery systems and their customer applications require an understanding of the application and a careful system design. Success also demands a balance between the level of thermal recovery achievable and the equipment and installation costs needed to secure that level of results. This is one of the reasons for the creation of the detailed RFC installation cost-estimating program contained in the CRN RFC demonstration tool kit.

Typical single-family residence thermal needs are highlighted in Table 2. These end-use requirements are for the actual energy needed—such as 20.9 million Btu for 80 140°F hot water gallons. Thus, if this requirement is supplied, for example, by a gas water heater at 65% efficiency, then the fuel saved by successful fuel cell thermal recovery would be far higher: 32.15 million Btu/year.

For completeness, the table shows all applicable residential thermal needs. However, thermal recovery for cooking and clothes drying are clearly out. These uses are low, and the required temperatures are too high for a PEM unit. Moreover, there is no practical way to even install a thermal recovery heat exchanger for these two appliances, and even if there were, the cost would be prohibitive.

Table 2. Typical Residence Thermal Needs

Residential Thermal Use	End-Use Thermal Requirement (Million Btu/Year)	Required Temperature and Typical Profile
Cooking	4.8	200°F–500°F ~1,000 burner hours per year
Clothes Drying	5.1	200°F–500°F ~300 burner hours per year
Water Heating	20.9	110°F–140°F Based on 80 gal/day hot water use. User already has site storage of 40–80 gal. 65% efficiency at \$7 natural gas is \$225 of fuel offset per year; \$1.15 propane, \$405 per year; 100% efficiency electric at \$0.06 power is \$367 per year.
Space Heating Atlanta, Georgia	32.5	90°F–140°F depending on system interface 3,730 hours below 60°F ambient outdoor 810 hours of furnace operation at an output of 40,000 Btu/hr 75% efficiency at \$7 natural gas is \$300 of fuel offset per year; \$1.15 propane, \$520 per year.
Columbus, Ohio	67.9	5,400 hours below 60°F ambient outdoor 1,700 hours of furnace operation at an output of 40,000 Btu/hr 75% efficiency at \$7 natural gas is \$630 of fuel offset per year; \$1.15 propane, \$1,090 per year.
Space Cooling Atlanta, Georgia	54.0	65°F depending on system interface and relative humidity 1,500 hours of 3-ton compressor operation
Columbus, Ohio	36.0	1,000 hours of 3-ton compressor operation
Residential Fuel Cell at 2.9 kW = 10,000 Btu/hour	87.0	8,760 hours per year

The heating and cooling profiles are based on a well-insulated, 2,000-ft², two-story home. Windows are assumed to be double-pane. This would typically require a 50,000-Btu gas, propane, or oil furnace or a 3-ton heat pump. Central cooling would also require a 3-ton unit. These details are covered in the CRN RFC demonstration handbook. Space cooling is not practical because there are no absorption units in the three-fourth-ton range, which is the most that could be expected from 10,000 Btu/hour of fuel cell thermal energy. Even if there were units available, the thermal loop temperature from a PEM fuel cell is too low to be practical, and the per-ton cost of such an absorption system would be astronomical.

Of the two remaining uses (water heating and space heating), water heating is more practical. It is a year-round load that operates in the “right” temperature range and, moreover, comes with built-in site storage. If the 10,000-Btu fuel cell thermal recovery can all be used, 15 gal of hot water an hour could be heated (compared with a typical residential use of 80 gal a day). Moreover, this use principally occurs during the day when the fuel cell is likely to produce at a higher output to either support dwelling electric loads or for larger dispatch to the grid.

Space heating shows some promise if related application issues can be overcome. The first is that 10,000 Btu is small compared with the likely furnace output, and a furnace operation of 800–1,700 hours represents only 9%–19% of the year. The second concern is that the 140°F thermal recovery temperature is low compared with the 180°F typically used for hydronic (water-filled) commercial building heat exchangers or residential baseboard units.

4.3 Water Heating

4.3.1 Residential Use Patterns

Thermal recovery is important for fuel cell economics and for reducing electric loads to manageable levels when dwellings include an electric water heater. Indeed, customer peak loads can be crucial in planning for RFC site demonstrations and future market applications. Here, the factor may not be the cost per kilowatt-hour but, rather, whether customer peak loads will actually fit within the fuel cell power plant’s overall capacity. This is particularly true for grid-independent remote installations, grid-parallel system users seeking better use of their power output, and the dual-mode grid-backup portion of grid-parallel applications.

Typical hot water uses are shown in Table 3. The table details typical use and calculates the time the water heater’s two 4.5-kW elements operate each day because of that demand.

RFCs typically have a 3–7 kW cell stack that may be supplemented by as much as 3–10 kW of DC batteries, at least for grid-independent remote applications. This composite DC buss feeds a DC-to-AC inverter sized for the power plant’s maximum specified load. Normal operation would charge the batteries during the night when the dwelling’s loads are low. The charged batteries then assist the unit’s supply of customer loads during peak, and perhaps normal, daytime operation.

As shown in Table 3, electric water heating can have 4.5-kW demands lasting 3–6 or more hours per day. The range of operation is directly related to the customer’s daily hot water use. Because a power plant’s cell stack size is around 5 kW, the electric water heater absorbs most of the fuel cell’s capacity for a rather low-tech thermal use of electricity. Thus, even if fuel cell thermal output were not needed to secure valuable fuel offset costs, thermal recovery for electric water heating dwellings is needed just to preserve the fuel cell’s electric output for more useful things such as running lights, computers, refrigerators, furnaces, well pumps, and similar equipment.

Table 3. Typical Residential Hot Water Use and Electric Water Heater Profile

Use	Consumption Gallons/Use	Uses per Day	
		Standard	High
Shower	20	2	4
Shaving	3	1	2
Washing Face/Hands	2	6	10
Food Preparation	6	1	2
Dish Cleanup	5	1	2
Dishwasher	15	0.5	1
Clothes Washer	15	0.3	0.5
Total Gallons/Day		78.0	150.5
Hours/Day at 4.5 kW		3.4	6.5
Resulting Load Factor		14.1%	27.2%

Note:

A typical electric water heater has an upper and a lower element of 4.5 kW each. These are controlled by separate upper and lower thermostats that are concurrently interlocked so that both elements cannot be on at the same time. If both thermostats call for heat, the upper element receives priority. Hot water leaves from the top of the tank, and heavier makeup cold water is admitted to the bottom of the tank through a dip tube. Thus, the lower element is the one that typically turns on first in the event of a hot water draw from the tank. The above hours/day calculation is based on the total gallons/day draw and assumes a cold water entering temperature of 60°F and a hot water exit temperature of 140°F.

Electric Water Heater:

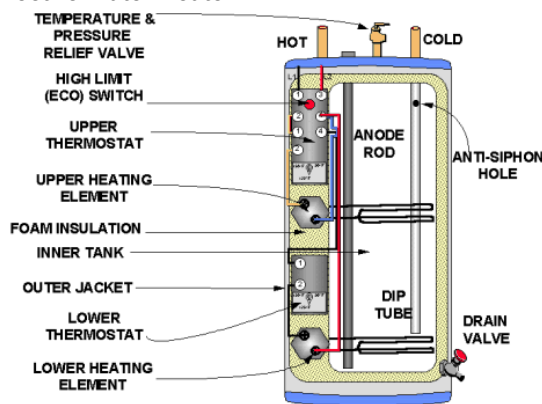

However, the electric water heater’s 4.5-kW elements would use up much of this reserve capacity for essentially negligible benefit. For example, at 78 gal of hot water use a day, the electric water heater would draw 4.5 kW of fuel cell output for about 3.5 hours/day. Moreover, it would not make sense to convert propane, for example, in a fuel cell at 33% efficiency to supply electricity for an electric water heater. This is particularly true when the alternate would be burning the propane directly in a water heater at around 65% efficiency or, even better, to use some of the fuel cell’s otherwise wasted thermal energy to supply the residence’s water-heating task.

**Table 4. Comparative Options for Electric Water Heating Residences
When a Residential Fuel Cell Is Added**

Parameters and Assumptions:

GPD	=	Gallons per day of hot water use
n	=	Efficiency of water heating, including tank wall daily losses, electric = 93%, gas = 65%
Mil Btu/yr	=	$GPD \times (140^{\circ}F - 60^{\circ}F) \times 8.33 \text{ lb/gal} \times 365 \text{ d/yr} / (n/100 \times 1,000,000)$
\$/yr	=	$0.374 \times GPD \times \$/\text{Mil Btu}$
	or	
kWh/yr	=	$GPD \times (140^{\circ}F - 60^{\circ}F) \times 8.33 \text{ lb/gal} \times 365 \text{ d/yr} / (n/100) \times (3412.6)$
\$/yr	=	$0.766 \times GPD \times \$/\text{kWh}$
\$/Mil Btu	=	\$7 for natural gas
	=	$0.1095 \times \$/\text{gal propane} @ 115\text{¢} = \$12.60 \text{ per Mil Btu}$
GPD	=	80

Existing Cost:

Electric Water Heating =	$0.766 \times GPD \times \$/\text{kWh}$	
	@ 4.5¢	\$276/year
	@ 6.0¢	\$368/year

Fuel Cell Application Options:

Recover Energy From Fuel Cell:*		\$ 0/year
Burn Fuel in Fuel Cell to Make Electricity for Electric Water Heater:	Natural Gas	\$542/year
	Propane	\$977/year
Convert Electric Water Heater to:	Natural Gas	\$209/year
	Propane	\$376/year

NOTE: At 10,000 Btu/hour of available thermal energy from an RFC operating at 2.9 kW, the thermal energy would be sufficient to heat 360 gal/day of hot water.
At a 9% cost of capital and a 10-year life, a \$1,000 thermal recovery expenditure would cost the equivalent of \$156 annually.

Average RFC applications in this analysis are based on a hot water demand of 80 gal/day. In comparison, extracted multiple regression appliance use data from 1,732 actual customers in the Energy Information Administration survey indicate an average hot water use of 51 gal/day. Alternatively, 4 years of data from gas and electric test homes with four-person families indicate a hot water use of 107 gal/day. Eighty gallons per day has been selected because it is consistent with Table 3's buildup data and because it most likely represents the higher-end income and dwelling data for homes in which fuel cells are more likely to be used.

In any heat pump application in which operation is required in remote or dual-mode grid-parallel, the supplemental resistance heaters in the air handler need to be replaced to reduce the load on the fuel cell. In this event, the simplest procedure may be to convert the electric water heater to a gas-supplemented fuel cell thermal recovery and then circulate some of that hot water to a hydronic coil in the air handler as a supplement to the air handler's electric strip heaters. The only alternative would be to substitute a gas furnace for the heat pump's air handler.

Table 4 showed the options for existing residences that have an electric water heater and subsequently install an RFC. The economics are based on 80 gal/day of hot water use but may be readily adjusted using the formulas for other consumption levels. Costs are shown for the existing electric water heating and options such as substituting a gas or propane water heater for the existing electric unit. Even if the electric load on the fuel cell were not a problem (such as at a remote location), using the fuel cell to make electricity for an electric water heater makes no economic or load management sense. The best option is to use fuel cell thermal recovery for most, if not all, of the water-heating task.

4.3.2 Customer Thermal Recovery Application Economics

Where it exists, thermal recovery credit can be viewed as an offset to capital-related fixed costs, a reduction of variable fuel costs, or an economic wash. For example, if 80 gal/day of the hot water needs of the dwelling are recovered, then the related annual savings of \$209 would be able to support \$1,340 for thermal recovery equipment and installation from the fuel cell and inside the dwelling. These values are based on a natural gas-fueled unit and water heater. As shown in Table 5, these offsets change significantly for propane fuel or electric water heating.

Table 5. Allowable Thermal Recovery Capital Costs to Offset Related Expenditures

Fuel	Natural Gas	Propane	Electric
Assumed Fuel Cost (\$/Mil Btu):	\$7	115¢ = \$12.60	6¢ = \$17.60
Water Heater Efficiency:	65%	65%	93%
	Gal/Day Hot Water Recovered	Annual Water Heating Savings at Zero Thermal Recovery Investment	
Annual Water Heating Savings:	80 150	\$209 \$393	\$377 \$707
		Thermal Recovery Investment That Would Offset All Annual Water Heating Savings	
Maximum Economic Thermal Recovery Capital Cost:	80 150	\$1,340 \$2,520	\$2,420 \$4,540
- 10-year life			
- 9% cost of capital			
Fuel Cost for PEM Power Plant at 30% Efficiency LHV at:			
- 1-kW average annual load		\$775	\$1,395
- 2-kW average annual load		\$1,550	\$2,790
- 2-kW average annual load		\$2,325	\$4,185

When a propane-fueled RFC interfaces with a propane water heater, the attractiveness of thermal recovery doubles even though the overall fuel cost is higher. For example, at 80 gal/day of water heating supplied by fuel cell thermal recovery, the annual savings at \$1.15/gal of propane would be \$377, and the maximum allowable investment to recover that energy would be \$2,420. This means that if the actual thermal recovery equipment and installation were to cost \$1,000, or 41% of \$2,420, then the customer savings after paying for the thermal recovery would be 100% minus 41%, or 59% of \$377. The savings would be \$222 each year, or 8% of the \$2,790 propane fuel cost if that customer's load averaged 2 kW for the year.

Thermal recovery to offset electric water heating can be particularly economic for grid-connected DG scenarios and has a two-fold advantage. First, it improves the fuel cell economics and might offset the propane cost of fueling the power plant. Second, the absence of the 4.5-kW load per element in the electric water heater considerably increases the ability of the fuel cell to meet the dwelling's other loads, particularly if an electric heat pump is part of that customer's energy portfolio.

Because of these potentials, thermal recovery is clearly a consideration as part of any site's demonstration and for commercial market planning. Of course, this assumes the selected manufacturer's fuel cell has thermal recovery capability. This is particularly needed for propane-fueled installations and those sites at which conversion from electric water heating is an option.

4.4 Water Heater Thermal Recovery Systems

4.4.1 Potable Water Direct Thermal Recovery System

4.4.1.1 System Cost

Fuel cell thermal recovery systems can be broken down into direct and indirect thermal recovery loops. Direct loops use the customer's potable hot water inside the fuel cell's thermal recovery loop. This is the least costly thermal recovery system to install because no new water heater or heat exchange coil is required. An added system circulating pump moves cooler potable water from the bottom of the customer's water heater tank through the RFC's own internal heat exchanger and returns it in heated form to the top of the water heater tank.

This thermal recovery system represents the minimum cost thermal recovery configuration that can achieve a high level of thermal recovery benefits. A detailed analysis of standard installation costs has been developed from the installation cost-estimating program contained in the CRN RFC demonstration tool kit. The "standard" cost estimate is for an outdoor installation that is 15 ft from the residence and includes basement plumbing for 20 ft to the existing water heater. The installation cost, including a circulating pump and temperature controller, is \$2,700. This includes one basement wall penetration, 15 ft of trenched insulated heat-traced interconnect tubing, and 30.8 labor hours.

4.4.1.2 Application

This system would convert an existing electric water heater for use as a storage tank by adding a small circulating pump with a controller. To provide a tank connection for cool water to the fuel cell's heat exchanger, the electric water heater's drain valve is used as a tap location. Alternatively, the water heater's cold inlet dip tube connection can be used. The water that is heated by the thermal recovery loop through the fuel cell returns to the water heater by an added connection at the water heater's hot water outlet.

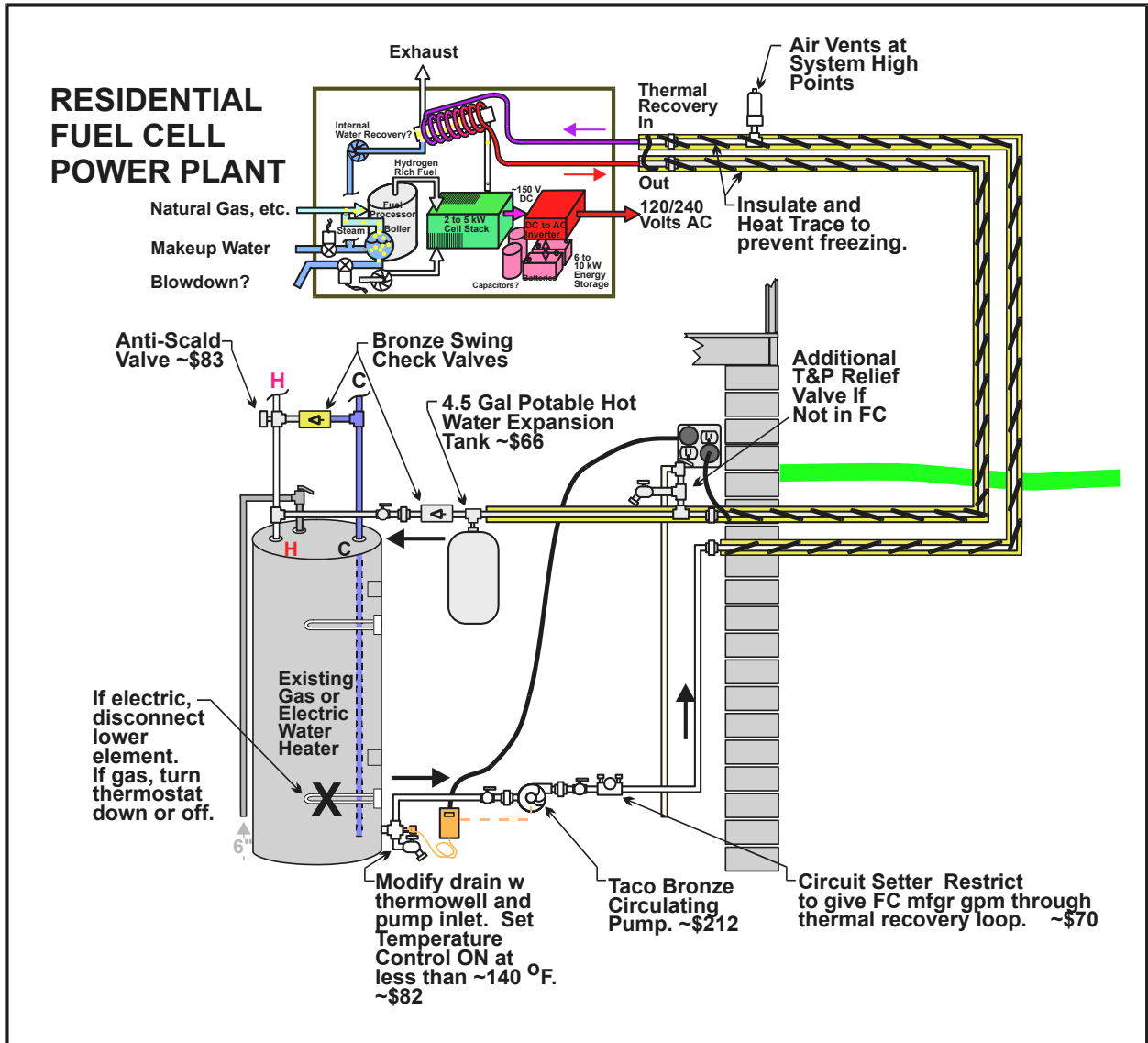

Figure 23. Potable water direct thermal recovery system

The controller manages the thermal recovery using readings from a temperature sensor added at the electric water heater’s modified drain valve. Upon a need for hot water for dwelling use, the controller senses a reduced temperature in the bottom of the tank because of cold makeup water flowing into the heater and turns on the circulating pump to send this cool makeup water through the fuel cell thermal recovery loop. The advantages of this system are the use of more precise temperature-sensing controls that can be set to the nearest 1°F with an independently adjustable deadband from 1°F–30°F and the reuse of the existing electric water heater as a storage tank. Because of the system configuration, an anti-scald valve should always be included in the dwelling’s domestic hot water supply line as shown. Because the fuel cell thermal recovery loop contains ordinary tap water, the related piping needs to be heat-traced in most climates. This electrical heat-tracing must be connected to a protected ground fault current interrupter outlet.

4.4.1.3 Thermal Recovery Loop Flow Control Critical

As illustrated in Figure 23, the heated water from the fuel cell thermal recovery loop is returned directly to the hot water inlet at the top of the water heater tank. This means the returned heated water is used almost immediately by the customer and must be at an acceptable temperature. The water heater tank setting might be in the range of 140°F, supplying typical shower or hand-washing temperatures of around 110°F. Returning a fuel cell-heated water temperature less than this will be unacceptable to the consumer.

Water return temperature is a complex issue that is affected by a number of factors. It depends on the amount of energy transferred into the loop by the fuel cell power plant, the flow rate through the loop, and the water temperature entering the loop from the bottom of the water heater. Assume for the moment that the fuel cell can transfer 10,000 Btu/hour, the loop flow rate is 2 gal/min, and the water temperature from makeup at the bottom of the water heater is 60°F. In this example, the return temperature at the top of the water heater is calculated as:

$$\text{Loop Temperature Rise} = \frac{10,000 \text{ Btu/hour}}{2 \text{ gpm} \times 60 \text{ min/hr} \times 8.33 \text{ lb/gal} \times 1 \text{ Btu/lb/}^\circ\text{F}} = 10^\circ\text{F}$$

$$\text{Return Temperature to Top of Water Heater} = 60^\circ\text{F inlet to RFC heat exchanger} + 10^\circ\text{F} = 70^\circ\text{F}$$

A 70°F shower is not acceptable to an RFC user. In contrast, if the loop flow were reduced to 0.4 gpm, then the temperature rise would be 50°F, and the return temperature entering the top of the tank would be an acceptable interim temperature of 110°F. This is the reason for the circuit setter in the application piping. The circuit setter is a valve that can be closed to reduce loop flow and a set screw to hold the setting in place. In this example, during the final installation setup, the tank would be filled with cold water and the circuit setter slowly closed until the return temperature reached at least 115°F.

This immediate return temperature does not affect the final tank temperature, which depends on the set point of the controller. For example, if the controller is set to 140°F and the customer draw ceases, the tank will continue to recover as the thermal recovery loop operates. The water temperature will continue to rise in the tank as warm water is pushed in the top and moves down the tank. This means that the inlet temperature to the RFC heat exchanger will increase as the loop continues to run without a water heater draw. As a consequence, the return temperature will move up the curve to reach 140°F or greater. The loop will finally stop circulation when the bottom tank temperature reaches the set point, in this example, 140°F.

4.4.1.4 Cross-Contamination Constraints

Because the dwelling's potable water circulates through the fuel cell thermal recovery loop, the loop and fuel cell thermal recovery exchanger must be constructed to potable water standards. Potable water is used for a dwelling's faucets and showerheads. Because a direct system comes in contact with the customer, all thermal recovery loop components must meet potable water standards. For example, lead solder cannot be used, and only approved piping materials and fittings are allowed. This typically means copper piping or tubing and a bronze circulating pump.

In addition, strict isolation must be maintained in any heat exchanger between the customer's potable hot water and other fluids—such as process water or heat transfer fluids—in the fuel cell. Any fluids in the fuel cell are assumed to be contaminated. Information about these types of concerns can be found at <http://www.epa.gov/safewater/pws/cc-all.pdf>. In addition, a number of municipal sites are linked via <http://home.sprynet.com/~geraldf/techzone.htm>.

To meet code, direct thermal recovery necessitates a double-wall fuel cell heat exchanger that has an air gap between the fuel cell fluid and the customer's potable water. The theory is that any leak from the “contaminated” fuel cell side will leak into the air rather than into the customer's potable water. It is also possible that any buried direct thermal recovery piping from the home's water heater to the fuel cell might have the same problems and risks as a buried lawn sprinkler system. Plumbing and code officials take these portions of the code very seriously and are necessarily rigid.

The suitability of an RFC for direct potable water thermal recovery applications should be evident from the manufacturer's equipment specifications, and any site installation should be discussed with applicable code officials. At this point, is not clear whether any PEM fuel cell manufacturer is delivering RFCs meeting the double-wall, air-gap thermal recovery heat exchanger requirement. Generally, a double-wall heat exchanger is not needed with solid oxide fuel cells, or for that matter with any fuel cell, that is exchanging heat directly between a gas and the residence's thermal recovery fluid. A double-wall, air-gap heat exchanger is only needed in the system where liquid-to-liquid heat exchange exists. Thus, it is unlikely that direct thermal recovery hot water heating systems can be used at present, and quite possibly for the foreseeable future, for PEM units.

Therefore, the only solution is to add a separate loop for the fuel cell to transfer heat across a double-wall, air-gap heat exchanger at the water heater end. In any event, a downside of a direct potable water thermal recovery is that the outdoor piping must be heat-traced to prevent freeze damage in most U.S. climates. This also applies to freeze protection of the heat exchanger inside the fuel cell power plant. In contrast, provided that a double-wall, air-gap heat exchange system is used at some indoor point in the thermal recovery loop, a distinct advantage of indirect, antifreeze-filled systems is that heat-tracing or freeze protection is not needed on the customer side of an outdoor thermal recovery loop.

4.4.2 Water Heater Control Issues

Using the customer's existing water heater has exceptional thermal recovery economic appeal. In effect, it is a free 40–50 gal storage tank that costs nothing because it is already purchased and installed. If it is an electric water heater, commonly found on co-op lines as well as elsewhere in the country, the only control interconnect needed is disconnection of the lower tank heating element. This arrangement still provides the customer with backup hot water if the fuel cell shuts down or cannot keep up with hot water use. However, the control issues are not as straightforward when existing gas or propane water heaters are used as “free” fuel cell thermal recovery storage tanks.

For gas water heaters connected to fuel cell thermal recovery, a significant difficulty discovered by the CRN RFC demonstration program is keeping the burner off to allow the fuel cell a chance to reheat the tank after the customer's hot water draw. At 10,000 Btu/hour, the fuel cell's thermal output can only heat 15 gal an hour. In contrast, a 50-gal gas water heater's burner provides 40,000 Btu/hour input. With an 80% flue efficiency, the same gas water heater can heat 48 gal/hour from an inlet temperature of 60°F to a hot water outlet temperature of 140°F. Thus, if both the gas water heater and fuel cell are trying to work at the same time, the fuel cell will only thermally provide 24% ($15 / (15+48)$) of the intended hot water. This is a serious problem because reasonable levels of thermal recovery are necessary to enhance fuel cell fuel economics and help national efficiency goals.

This control infighting occurs because of the water heater's fundamental design. Whether they are gas, propane, or electric, all water heaters are designed to maintain a thermocline of static hot water at the top of the tank and a cool layer of makeup water on the bottom. As illustrated in Table 6, this is accomplished by connecting the 140°F hot water outlet to the top of the tank and the cold water inlet to a dip tube that extends down to the bottom of the tank. This design for introducing makeup water prevents the cold, higher-density 60°F entering water from unduly mixing with the lower-density, lighter hot water layer already heated in the upper tank.

A typical electric water heater has a 50-gal capacity and two 4.5-kW elements, each capable of heating 23 gal of water an hour from inlet to outlet temperatures. These temperatures are typically 60°F and 140°F, respectively.

To reduce the recovery time, the upper and lower elements have individual thermostats. To prevent unacceptably large current draws, the thermostats are interlocked, and the upper element is preferred. As a result, the lower element will not come on unless the upper element has already heated its portion of the tank to its set temperature. At that point, the satisfied upper element's thermostat, which is an SPDT switch, allows current to flow to the lower thermostat to heat that portion of the tank. For a 50-gal tank, about 80% of its capacity, or 40 gal, is below the upper thermostat.

To prevent an electric water heater from interfering with the fuel cell's thermal recovery, one must only turn off the lower element's thermostat or disconnect its wiring. In contrast, a conventional gas water heater has a mechanical pressure-type thermostat located only about 6 in., or 4–6 gal, above the bottom of the tank. Moreover, the gas water heater thermostat bulb is threaded into a hole in the tank and directly connected to the pilot light and burner tubing it controls. Thus, a gas water heater's thermostat cannot be moved higher up the tank.

Table 6 displays typical dwelling hot water uses and thus indicates the likelihood that the water heater's lower element or burner will be tripped on even though the tank may still have 30–40 gal of hot water to supply the customer's load. The table indicates that all these uses are likely large enough to activate a conventional gas or propane water heater's thermostat. For gas and propane water heaters, these flow interferences greatly limit fuel cell water heating thermal recovery.

Table 6. Actual Hot Water Draw for Typical Residential Uses

Type of Load	User Temperature, Load, and Likely Duration	Hot Water Tank Draw*	
		Flow Rate (gpm)	Total (gal)
Shower (Large Nozzle)	112°F at 4 gpm for 10 min	2.6 gpm	26 gal
Shower (Normal Nozzle)	112°F at 2 gpm for 10 min	1.3 gpm	13 gal
Hand Dishwashing	112°F at 1 gpm for 8 min	0.65 gpm	5.2 gal
Clothes Washer (Warm)	102°F at 3.7 gpm per 2.5-min fill	3.7 gpm	9.2 gal

*At 140°F from hot water heater needed to blend with 60°F cold water
 Note: All data are from actual field measurements.

One solution is to turn a gas water heater's thermostat off or all the way down. However, in a demonstration program in which fuel cells may not be totally reliable, the customer is greatly inconvenienced by having to reset the temperature control every time a fuel cell shuts down or cannot keep up with the dwelling's hot water load.

However, workarounds are under way. Alternatives for fuel cell thermal recovery being assessed and/or demonstrated for dwellings with existing gas or propane water heaters include:

- Using fuel cell thermal recovery via a front-end solar storage tank to preheat makeup water to a conventional gas water heater (Because the normal gas water heater never sees cold makeup water, its burner remains off, and the pilot light continues to do its 500-Btu/hour job of making up for existing water heater tank wall and flue losses.)
- Using power-vented gas water heaters because their special control system uses a conventional electrical thermostat that can be held open by an added contact thermostat further up the tank wall
- Reconfiguring the dip tube and external heat exchange with the fuel cell's thermal recovery in such a way that the conventional gas water heater thermostat is less likely to see cold makeup water to trigger the burner.

Again, these options only need to be explored for dwellings with existing gas or propane water heaters. For existing electric water heaters tied to fuel cell thermal recovery, the only action needed to prevent control interference between the water heater and the fuel cell thermal recovery is to disconnect or turn off the lower element of the electric water heater.

4.4.3 Indirect Thermal Recovery Tank in Front of Existing Water Heater

4.4.3.1 System Cost

Given the code issues associated with running potable water through underground lines to the fuel cell and the power plant's normal thermal recovery heat exchanger, an alternative cost-effective option is an indirect system using a Rheem Solaraide HE tank, shown in Figure 24. The resulting system has air-gap, double-wall heat exchange to heat the customer's potable water inside the tank.

A detailed analysis of likely installation costs for a standard installation has been developed using the installation cost-estimating program in the CRN RFC demonstration tool kit. This cost estimate, for comparative purposes, uses a "standard" outdoor installation 15 ft from the residence and includes basement plumbing for 20 ft to the existing water heater. The resulting cost with installation is \$3,690. This includes an 80-gal Rheem Solaraide tank that incorporates an external-wound, double-wall, air-gap thermal recovery coil; a circulating pump and temperature controller; and all related hardware. This encompasses one basement wall penetration; 15 ft of trenched, insulated, heat-traced interconnect tubing; and 37 installation labor hours.

4.4.3.2 Application

The tank of preheated water is connected to the cold water inlet of the customer's existing water heater and has the advantage of providing additional hot water storage. Because the Rheem tank is 80 gal, the combined hot water storage would likely be 120–130 gal, depending on the residence's hot water heater. Upon a draw of hot water for dwelling use, the controller on the side of the Rheem tank senses a reduced temperature in the bottom because of cold makeup water flowing into the tank on its way to the customer's existing water heater.

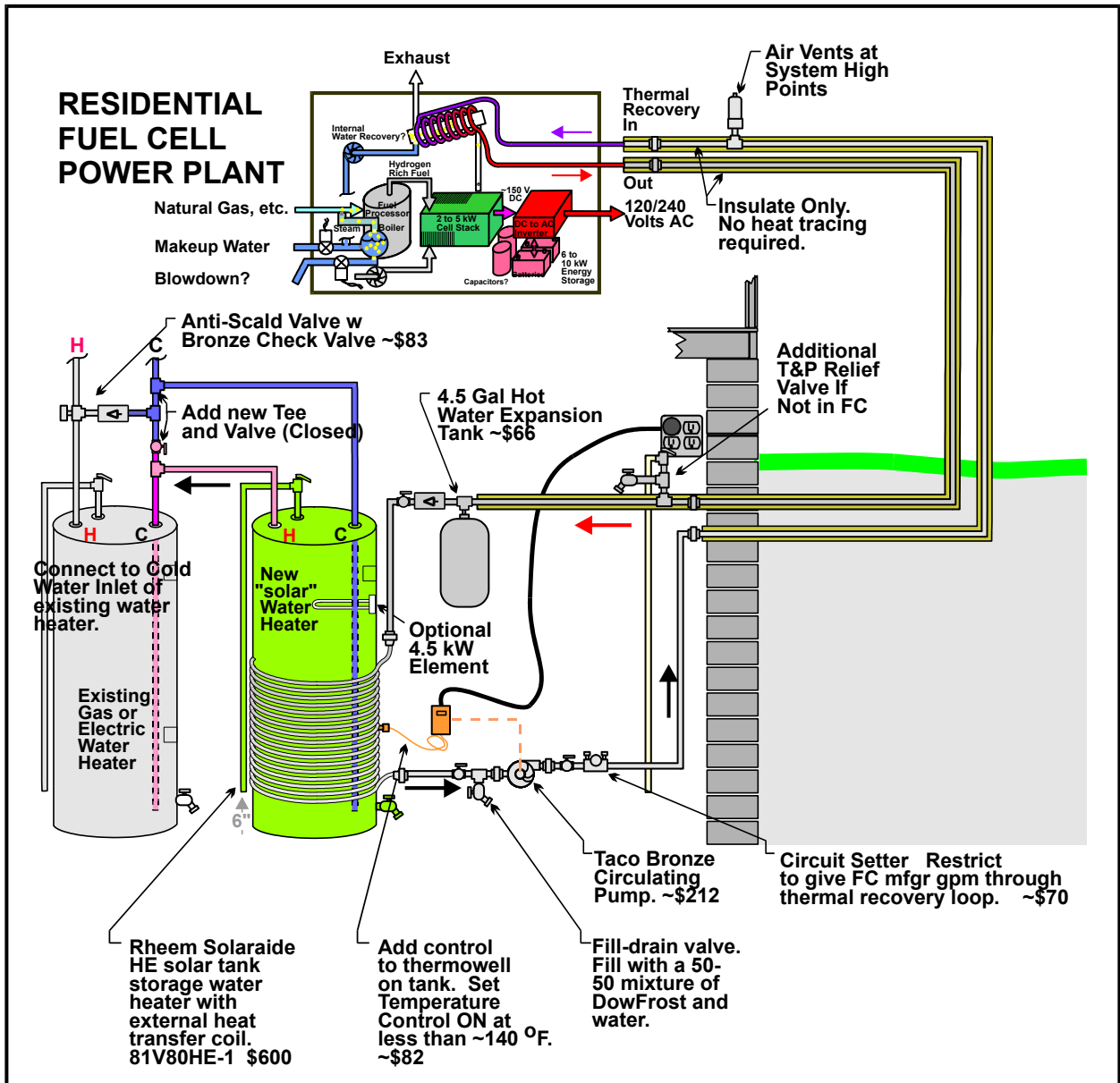

Figure 24. Indirect thermal recovery tank in front of existing water heater

This thermostat starts a small pump that circulates fluid in an isolated loop from the Rheem tank's external coil through the fuel cell heat exchanger. This indirectly heats the makeup water in the Rheem tank so that the customer's existing water heater is always fed preheated hot water. In addition, if the fuel cell cannot keep up with the customer's hot water load or is shut down, the customer's existing water heater still operates normally to avoid inconvenience to the dwelling residents.

The efficiency of electric hot water heating is generally around 93%. Because the actual water heating itself is 100% efficient, the balance, or 7%, is heat loss through the water heater's tank wall. Given a customer use of 80 gal/day, the actual load for heating the water is 53,300 Btu/day, with an imputed tank heat loss of 4,000 Btu/day. This assumes an 80°F rise with a 140°F thermostat setting and a 60°F cold water inlet temperature. Thus, the temperature decrease per day would be 7.5% (4,000 Btu loss / 53,300 heating Btu) of the 80°F rise, or around 6°F per day.

Such a low loss means that using a pre-heat tank in front of the water heater should require little makeup heat to the water heater. For example, even if the residence used no hot water, several days would elapse before the customer's water heater dropped to 110°F. This means that adding an indirect thermal recovery tank in front of the residence's existing water heater has the potential to fully recover the hot water heating load from the fuel cell system.

Even though gas water heaters have a higher tank wall heat loss because of the addition of a central flue, the pilot light's 12,000 Btu/day is generally sufficient to make up for this loss. Nonetheless, this pilot light does represent 15% of non-recoverable gas water heating fuel use. Turning off the pilot light obviates using the customer's water heater as a backup should the fuel cell shut down or not meet the dwelling's load. Power-vented units, however, do not have a pilot.

4.4.3.3 Installation Commonalities

As shown in figures 23–25, these systems have a number of common physical configurations:

- The thermal recovery loop's circulating pump should be mounted with discharge pointing up to clear air blockages during thermal recovery loop setup.
- Air vent bleed should be installed in an upward tee-elbow at the top of the pump's discharge vertical riser and at all applicable high points to aid commissioning.
- Any closed or potentially closed thermal loops must have a TP relief valve at a suitable location.
- As with any hot water heating thermal recovery system, an anti-scald valve should be added at the final hot water outlet to the residence.
- All valves in the thermal recovery loop should have "hot" warning tags and, where applicable, Dowfrost/propylene glycol antifreeze fill warnings.

4.4.4 Replace Existing Water Heater With Indirect Thermal Recovery Unit

4.4.4.1 System Cost

If the customer has ample space and an indirect thermal recovery water heating system is needed, it will always be cheaper to use the Rheem system shown in Figure 24. However, if sufficient space is not available (as may be the case for homes that do not have a basement utility group), then the existing water heater will need to be removed or a special small footprint external heat exchanger added. One feasible option, especially for homes needing a new natural gas or propane water heater, is the combination thermal recovery system and water heater illustrated in Figure 25.

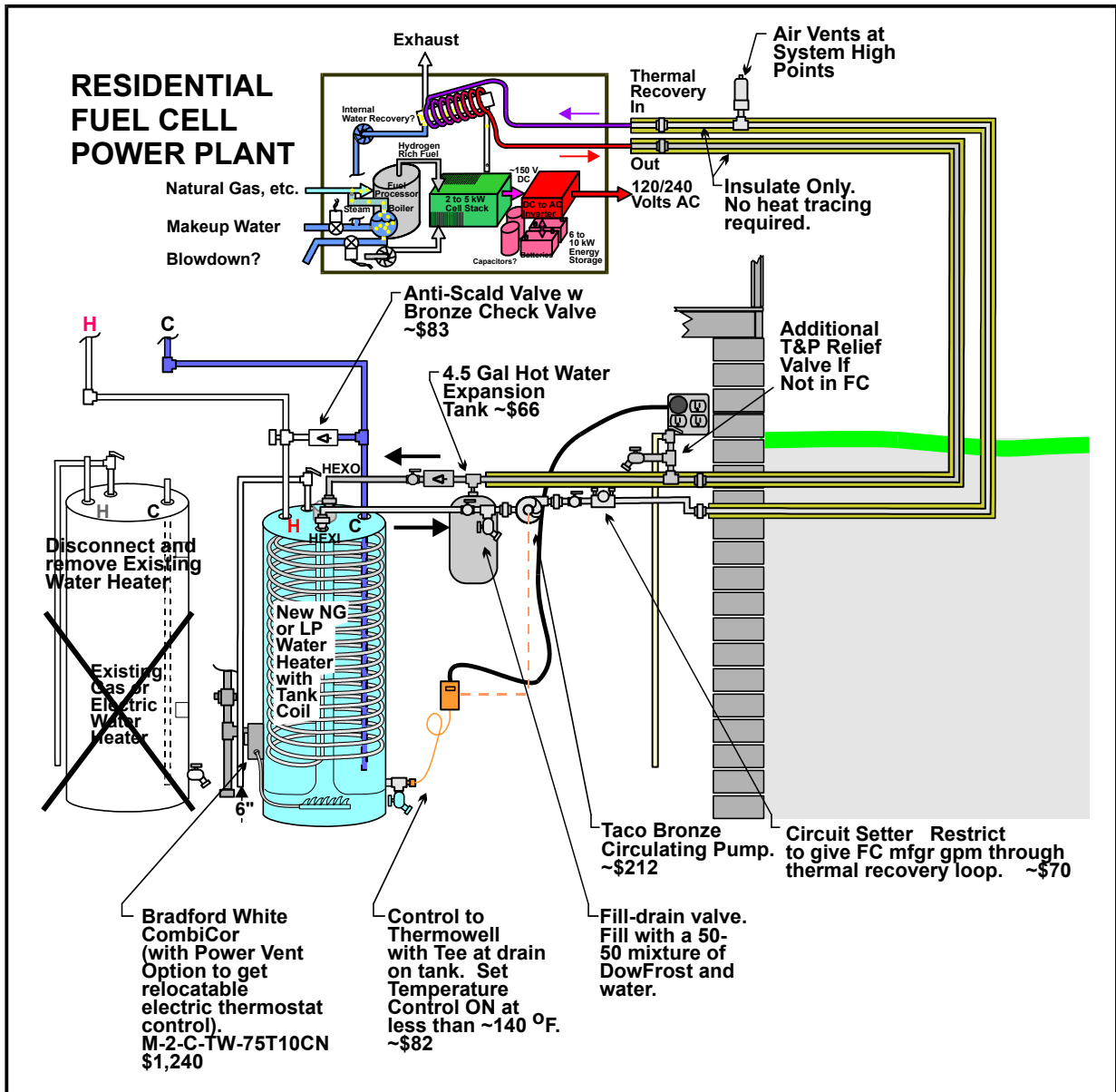

Figure 25. Replace existing water heater with indirect thermal recovery unit

A detailed analysis of likely installation costs for a residential application was developed for a standard installation using the installation cost-estimating program in the CRN RFC demonstration tool kit. The cost is \$5,020. This includes a 75-gal Bradford White CombiCor natural gas or propane water heater that incorporates an internal, double-wall, air-gap thermal recovery coil; plastic pipe power venting without a chimney; circulating pump and temperature controller; and all related hardware with installation. This also includes \$1,200 to purchase the internal coil power-vented gas water heater. The installation configuration includes one basement wall penetration; 15 ft of trenched, insulated, heat-traced interconnect tubing; and 46.6 labor hours. If conventional venting were used to an existing chimney, the cost could be reduced by \$625, of which \$350 is labor.

4.4.4.2 Application

The existing gas or electric water heater is replaced by a new natural gas or propane unit. As shown in Figure 25, the replacement water heater has a built-in double-wall, air-gap heat exchange coil inside the tank. Although this coil is commonly used to transfer heat from the water heater to an external space-heating baseboard for an add-on room, it works just as well in reverse to transfer heat into the tank from an external fuel cell thermal recovery loop.

Two types of units are available. One uses a conventional burner, controls, and venting. The second adds a draft fan and controls for venting the water heater's burner exhaust by means of an ordinary 3-in. plastic pipe through a wall. This is for installations in which a chimney is not available, such as a retrofit of an electrically heated home.

The circulating pump for the fuel cell's thermal recovery loop is operated by a thermostat added to the drain valve fitting at the bottom of the water heater tank. Upon a need for hot water for dwelling use, the controller senses the reduced temperature in the bottom of the tank because of the cold makeup water flowing into the heater and turns on the circulating pump. Hot thermal recovery fluid from the fuel cell then circulates downward through the coil inside the water heater. The cooler thermal recovery fluid from the lower end of the coil at the bottom of the tank then enters the circulating pump and is sent back to the fuel cell's internal heat exchanger for reheating.

For this loop to work properly in conjunction with a normal gas water heater thermostat, it is important that the circuit setter be adjusted to provide at least a 25°F drop across the hydronic coil, and preferably to a coil inlet temperature of at least 120°F. Because of the system's configuration and as is the case for all thermal recovery systems being used for potable water heating, an anti-scald valve should always be installed on the dwelling's domestic hot water supply line.

4.4.4.3 Pilot and Control Coordination Issues With Conventional Gas Water Heaters

One potential difficulty with this control system is that the normal Bradford White system, like that of all manufacturers, uses a conventional pressure-filled bulb burner thermostat. This is fixed to an opening in the bottom sidewall of the tank and cannot be moved upward to allow the fuel cell thermal recovery system a "first chance" to heat the water in the tank. Thus, the burner thermostat will need to be turned down to its lowest temperature setting or perhaps even to the off position.

Even so, a conventional gas water heater has a 350–500-Btu/hour, continuously burning pilot light that represents 10%–15% of a natural gas or propane water heater's use. This represents non-recoverable thermal energy for the RFC unless the gas supply to the water heater is turned off. However, if the gas is turned off, the customer will have no automatic hot water backup if the fuel cell cannot supply the dwelling's hot water demand or when the fuel cell shuts down.

Manufacturers have no incentive to change from a standing pilot to an electric, pilotless ignition (with the exception of power-vented water heaters). This is because the pilot does a useful job of making up for tank losses and because a normal electric ignition water heater would need a 110-V electrical supply and igniter with the attendant extra electric outlet installation cost.

4.4.4.4 Power Venting Enhances Full Thermal Recovery

In contrast, a power-vented residential gas water heater already needs a 110-V supply for the blower motor and an interlocked control system so that the burner does not come on unless the proper low pressure is present in the flue. Although more expensive, a power-vented water heater can vent through the wall via low-temperature plastic pipe and contains a control system that can be integrated with the fuel cell thermal recovery loop.

A power-vent system enhances installation flexibility when a gas water heater has to be added to an RFC installation and no existing chimney is available. An example is a unit that is used as a retrofit to an existing electric water heater in an all-electric home. As explained in the manufacturer's installation instructions, the unit may require an outside opening for combustion air in a tightly constructed dwelling such as an electrically heated home.

The power-vented system in Figure 25 is a through-the-wall version of the more conventional Bradford White water heater with an internal, double-wall, air-gap heat exchange coil. The M2-C-TW-75T10CN model uses a flue gas blower and ordinary 3-in. PVC pipe as the vent. This system adds an electrical burner thermostat that can be precisely set and includes a pilotless ignition system. Thus, the tank thermostat can be connected in series with an added upper tank thermostat to reserve burner operation for only those times when the fuel cell's thermal recovery loop cannot keep up with the customer's hot water demand or during a fuel cell shutdown. Moreover, because this unit does have a standing pilot, all of the water heating fuel consumption could, at least theoretically, be provided by fuel cell thermal recovery—including the 10%–15% normally used for a gas water heater's pilot light—while preserving an automatic customer hot water backup. However, this extra thermal recovery potential is not free. The added cost of installing a power-vented version of a conventional water heater can reach \$650 including materials and labor.

4.4.4.5 Antifreeze-Filled Thermal Recovery Loop

The coil inside the gas water heater has a special double-wall, air-gap leak detection system to isolate the thermal recovery coil from the tank's potable water. This obviates any concern that contamination of the potable water side could occur via the fuel cell power plant if an air gap does not exist inside the fuel cell's own heat exchanger. This special double-wall coil also minimizes permitting problems. Cross-contamination is always a concern when potable water is involved on one side of a fuel cell thermal recovery system. Even so, for added safety, this fuel cell heat exchange closed system should be filled only to an operating pressure of about 15 psig as set by the loop's expansion tank. This low loop pressure adds a second level of security independent of the vented air gap because any leak would likely go from the higher-pressure potable hot water into the thermal recovery loop rather than in the other direction.

Thermal recovery piping should be insulated. In the likely event that the fuel cell is located outdoors, the piping will have to be heat-traced if ordinary water is used. An alternate is to fill the fuel cell thermal recovery loop and tank coil with a low-toxicity antifreeze mixture consisting of propylene glycol DowFrost and demineralized water. Because the heat exchange coil in the tank is a double-wall configuration with an air gap, no permitting concerns should exist even when it is filled with a propylene glycol. Even so, the system should be reviewed in advance with state or local code officials and the fuel cell manufacturer.

If Dowfrost is used in the system, the system's valves, drains, and fill ports should be clearly labeled and tagged so Dowfrost is not inadvertently introduced into the potable water system. In addition, any Dowfrost system should have special fill ports to further reduce the chance of a fill error. Under no circumstance should an ordinary ethylene glycol automotive antifreeze mixture be used in any fuel cell thermal recovery loop—even if it has a double-wall, air-gap heat exchanger—because of environmental, corrosion, and serious toxicity hazards.

4.4.4.6 Reduced Heat Pump Grid Kilowatt Demand and Emergency Space Heating

Because this particular Bradford White water heater has a 75,000-Btu burner capable of supplying 60,000 Btu/hour, it opens a dimension of flexibility for hydronic-assisted heating. Although such loops are normally used only for add-on rooms, these systems are known as combination systems and are used in small homes, in which they are simpler and more efficient than a normal gas furnace.

An additional circulating loop can be added to provide supplemental or emergency space heating. This would be an “open” loop that uses an additional circulating pump to draw 140°F hot water from the water heater's potable water outlet, circulate it through a hydronic coil in the furnace or heat pump air handler duct, and return it through the cold inlet dip tube back into the water heater tank for reheat. This type of open potable water loop for an air handler hydronic coil is generally approved by local code authorities but should be checked during site planning. Of course, all components in the loop must be approved for potable water use. An exercise timer can also be included as part of the loop to alleviate stagnation concerns.

The resulting hydronic heating loop fed by the newly installed water heater system could:

- Provide emergency heat to a heat pump home in the event of a grid outage

If located in a duct downstream of a heat pump air handler, the hydronic coil could provide emergency heat in the event of a grid outage in which the fuel cell's electrical output is not sufficient to power both the normal dwelling base load and the heat pump compressor. During a winter grid outage, the system could be arranged so that the air handler blower and the additional duct heating circuit turned on to provide emergency heating. Indeed, the system should be capable of maintaining normal indoor temperatures in an “electric heat-insulated,” 2,000-ft² home down to an outdoor temperature of 0°F. Such a system would be applicable to heat pump homes or electrically heated homes that have forced-air ductwork for central cooling.

- Replace up to 16 kW of heat pump winter-peaking supplemental heaters, thereby reducing the home's electrical demand on the grid beyond the DG effect of an RFC.

This occurs because the typical air-sourced central heat pump system is a high-end space conditioning system that serves a dual purpose. In the summer, the air in the home's air handler-duct system serves as a thermal source to evaporate the refrigerant that has been compressed and re-condensed to liquid in an outside unit. In effect, the heat pump operates as a conventional central air-conditioning system. In the winter, the cycle is reversed. The outside ambient air becomes the source to evaporate the refrigerant, which is then condensed in the home's air handler coil, releasing heat. Unfortunately, as the ambient outdoor temperature decreases, the home's heat loss and related heating demand increase and heat pump output declines because of the larger indoor-to-outdoor temperature difference. When outdoor temperatures reach around 20°F –30°F, the heat pump's capacity is no longer sufficient, and supplemental electric resistance heaters in the air handler kick in to supply needed heat. Because the supplemental heater load is larger than the normal 3-kW heat pump compressor load and occurs at low ambient temperatures, the heat pump supplemental heater demand is a very unattractive grid use likely coincident with winter peak loads. Thus, this configuration offers a DG advantage for electric utilities having space heating winter peaks. This issue is less pronounced with ground source heat pumps because they have a higher winter source temperature.

Adding this type of external hydronic heating loop for emergency space heating or peak reduction has been analyzed using the installation cost-estimating program in the CRN RFC demonstration tool kit. The hydronic space-heating loop would cost \$1,590, including 15.8 hours of labor. This assumes a 10-ft interconnect and includes adding a hydronic coil to existing ductwork, the circulating pump, air bleeds, anti-stagnation timer, and all other necessary controls.

4.4.5 Additional Systems Under Assessment

Fortunately, fuel cell thermal recovery can take advantage of systems already developed by the solar water heating industry. One example is the Rheem Solaraide hot water heater pre-heat configuration. This system is already installed at one DOD site within the CRN RFC demonstration program. Two other new equipment examples are shown in Figure 26. One of these is a Wand that inserts into the outlet of an existing water heater; the other is a Heliodyne external U-shaped heat exchanger with two circulating pumps, expansion tank, TP relief valve, and controls. Both units are double-wall, air-gap heat exchangers and suitable for propylene glycol-filled thermal recovery loops to the fuel cell power plant. These systems were identified by LoganEnergy personnel in the DOD military base program and in the CRN RFC demonstration program.

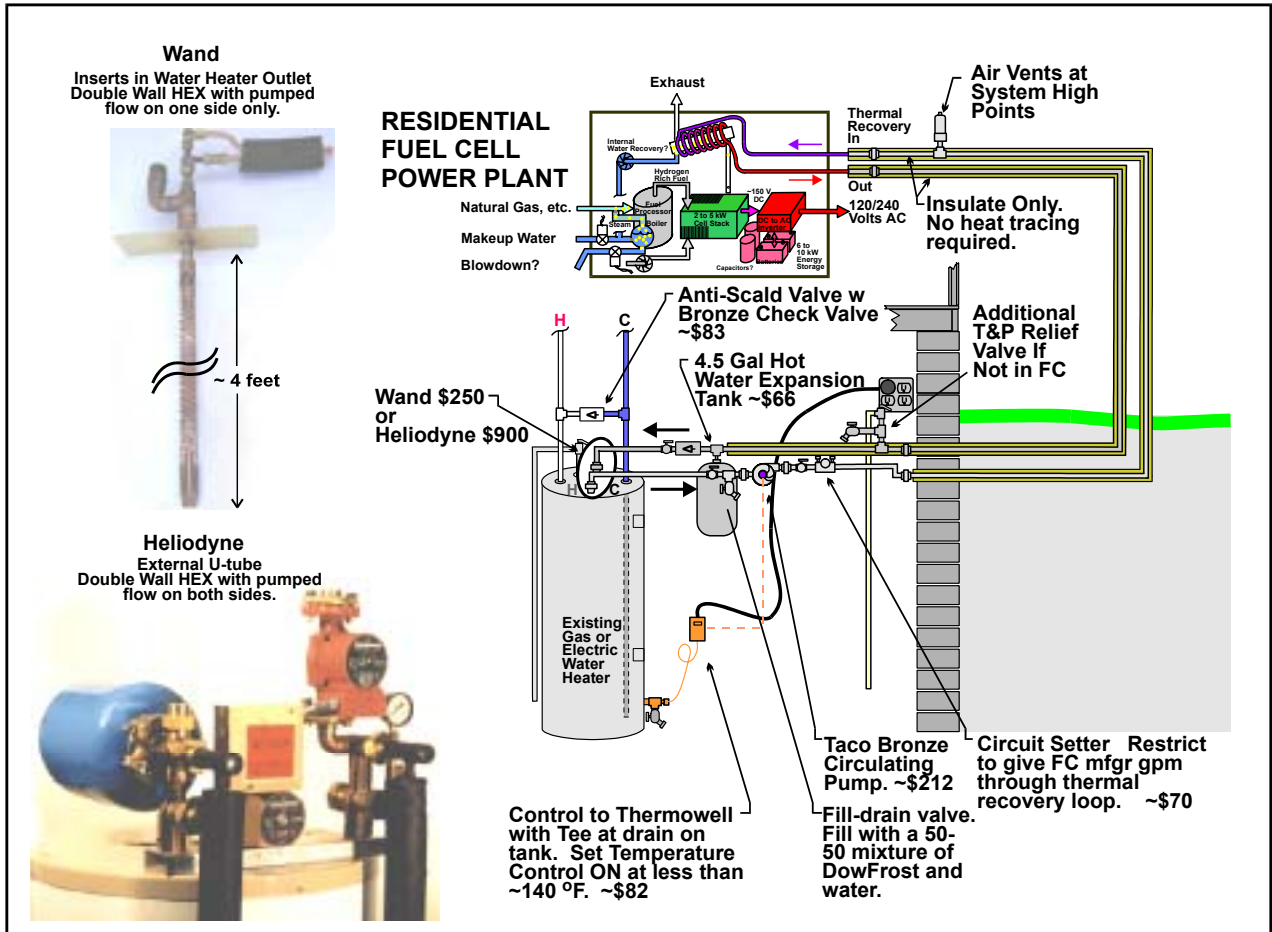

Figure 26. Additional thermal recovery systems under assessment

The basic supply and return piping for the propylene glycol-filled system between the water heater and the fuel cell are detailed on the right of the figure and cost \$1,920 for the standard installation. This includes 25.3 hours of labor. Based on the installation cost-estimating program, the circulating pump, expansion tank, TP relief valve, controls, and hardware for the Wand system would add \$1,350, including 10.5 labor hours. This would yield a Wand system total cost of \$3,270.

In contrast, the Heliodyne is a pre-fabricated system that costs an estimated \$900. However, this includes two pre-installed circulating pumps, an expansion tank, a TP relief valve, and a control package. The estimated installed cost for that portion of the system is \$1,560, including 9.3 labor hours. The total installed cost of the Heliodyne external heat exchange thermal recovery system is \$3,480.

Although both systems show potential, the Wand has a smaller effective heat exchange surface area than the external U-tube heat exchanger. Both systems illustrate the benefit of continuing to search for applicable cost- or performance-effective fuel cell thermal recovery equipment in other innovative applications such as the off-the-grid or solar water heating applications.

4.5 Combination Space Heating and Water Heating Thermal Recovery

4.5.1 Application

Space heating thermal recovery has one and one-half to three times the potential thermal use of water heating. Space heating is not normally considered for fuel cell thermal recovery because of the relatively short annual operation of furnaces. However, when carefully combined with pre-existing water heating thermal recovery, the incremental cost of residential space heating may be attractive. Figure 27 is such a system.

This configuration starts as a standard indirect thermal recovery system for an existing gas or electric water heater. This segment consists of an external double-wall, air-gap heat exchanger that is essentially a shell-and-tube device. Included as part of the pre-assembled package are a counter flow heat exchanger, a main circulating pump for the thermal recovery loop, a secondary circulating pump for cycling water heater potable water through the heat exchanger, a thermal expansion tank, a TP relief valve, and the related control system. These components are all clustered at the top of the water heater.

As the residence begins to draw hot water and the water heater tank cools, the control system turns both circulating pumps on. The main circulating pump circulates fuel cell thermal recovery fluid through the loop from the fuel cell through the center tube in the heat exchanger. At the same time, a second pump circuit moves cool makeup water from the hot water heater in a counter direction through the outside “shell” surrounding the center fuel cell thermal recovery tube in the U-shaped heat exchanger. Because the heat exchanger is a double-wall, air-gap unit, a Dowfrost mixture can be used in the fuel cell thermal recovery loop to eliminate freezing problems with the outdoor portion.

The space-heating portion of thermal recovery is an add-on set of components comprising:

- A three-way valve that acts as a bypass around the U-tube heat exchanger

When additional hot water is needed, the controls at the water heater start both circulating pumps, and the three-way valve energizes to divert thermal loop flow through the U-tube heat exchanger’s center tube. Conversely, if the water heater circuit is not calling for water heating, the three-way valve reverts to its off position, and any thermal loop flow bypasses the U-tube by diverting to the U-tube heat exchanger’s outlet.

- A slide-in hydronic heating duct coil mounted in the space-heating airflow inside the furnace

In a conventional furnace with a relatively high heat transfer temperature, the coil needs to be located in the lower portion of the furnace between the existing filter and the furnace hot air blower. This coil is oversized so that maximum heat transfer can be obtained, air pressure drop is minimal, and the coil face area is consistent with the typical furnace filter dimensions. The latter minimizes the cost and pressure drop of any coupling sheet metal work.

If the residence uses a heat pump, the thermal recovery coil is located above the heat pump coil because it has a relatively low surface temperature when in heating mode. Thus, if the thermal recovery coil were before the heat pump, it would interfere with the heat pump's own heat transfer. Having the thermal recovery coil downstream also has the bonus of returning air warmed a further 5°F–8°F, which helps counter a frequent psychometric homeowner complaint that winter heat pump forced-air systems feel too “cool” for comfort.

- An adjustable temperature control to sense outdoor temperature.

At an outdoor temperature of 60°F, the control closes and turns on the main thermal recovery loop circulating pump if it is not already operating. At the same time, it unlocks a three-way valve at the space-heating hydronic coil. This valve is normally in the bypass position and diverting thermal loop flow around the space-heating hydronic coil.

However, if space heating is needed and the loop temperature is above a set point such as 110°F, the three-way valve activates to direct thermal loop fluid through the hydronic coil for space heating. This prevents the furnace from blowing cool air if the water heater thermal recovery is also on and, therefore, using most of the fuel cell's thermal recovery energy. When the three-way valve operates to supply space heating, a contact in the valve automatically bridges the furnace fan switch to start its blower.

An alternative, more precise control system replaces the customer's conventional heating thermostat with a unit with two heat settings. This permits the thermal recovery hydronic space-heating coil to always have the first chance to provide thermal recovery space heating for the residence.

Although the thermal recovery system may appear complex, it is actually relatively straightforward. It consists of a water heater thermal recovery circuit and a space heating circuit arranged in series, with the water heater given priority. The thermal recovery loop flows past these thermal recovery users and incorporates a three-way valve and related controls to control each use. If either of these uses can use the fuel cell's thermal energy, the controls are paralleled so that either turns on the fuel cell thermal recovery loop.

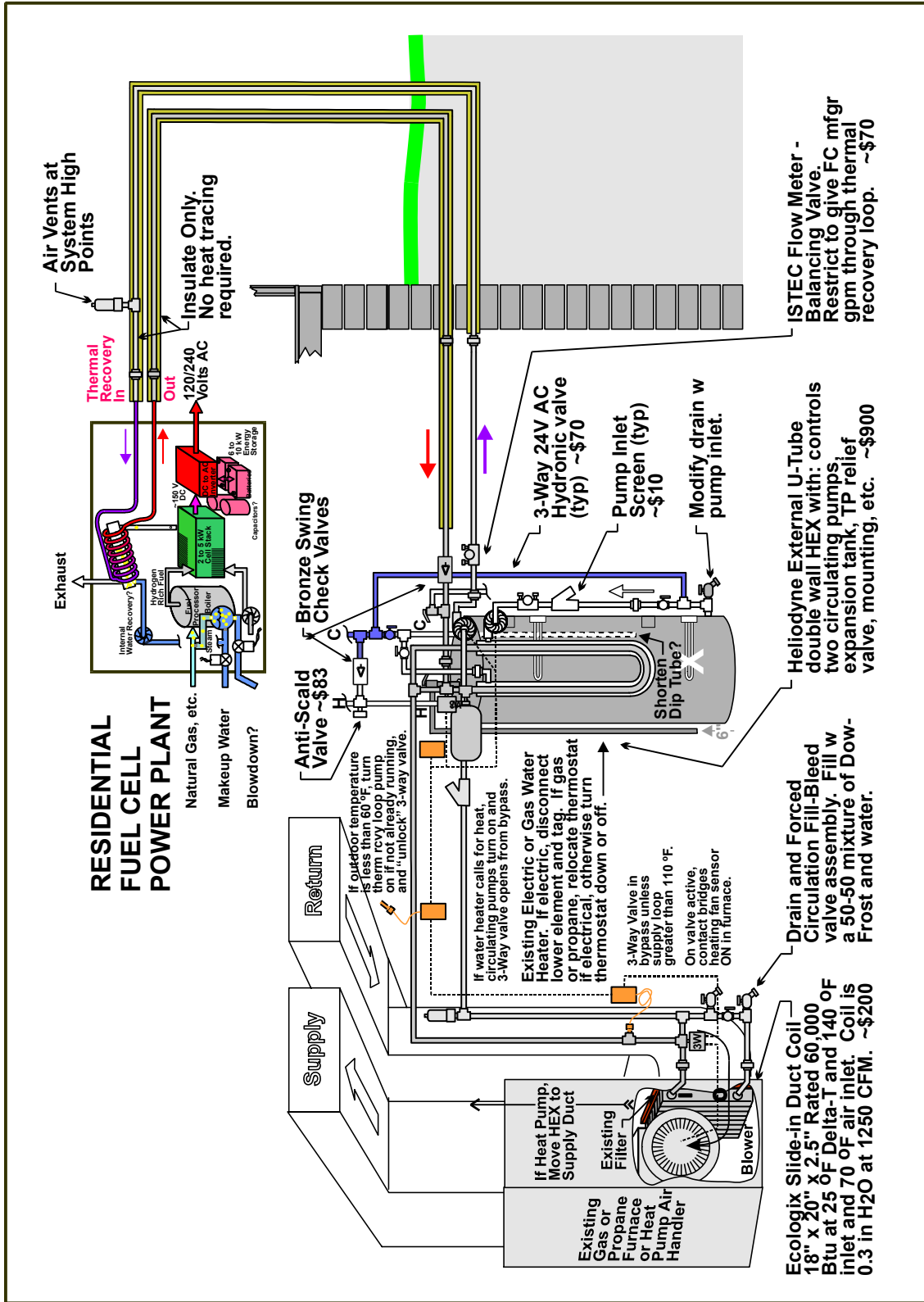

Figure 27. Combination space heating and water heating thermal recovery

4.5.2 System Cost

The Heliodyne U-tube heat exchanger is a pre-fabricated system that costs \$900. However, this includes two pre-installed circulating pumps, an expansion tank, a TP relief valve, and a control package. The estimated installed cost for this portion is \$1,560, including 9.3 labor hours. The \$3,480 estimated total installed cost adds the main thermal recovery loop to the hot water heater portion. This total includes 34.9 labor hours as well a 15-ft trenched outdoor interconnection, a basement wall penetration, and a 20-ft indoor distance to the hot water heater.

According on the tool kit's installation cost-estimating program, adding the space heating thermal recovery would cost an additional \$2,070. This would include a 15-ft distance from the water heater to the furnace, purchasing and installing a 60,000 hydronic coil in the furnace ductwork, two three-way bypass valves, and all related controls. This portion of the system labor is 20.2 hours.

The overall installed cost for fuel cell thermal recovery for water heating plus space heating would be \$5,550, which includes 55.1 labor hours. Because the space-heating portion can be added to any of the thermal recovery water heating systems described earlier, the same dual thermal recovery system would cost about \$4,770 for a potable direct water heater thermal recovery system.

4.5.3 Comparative Thermal Recovery Economics

Calculating the thermal recovery savings from space heating is a complex undertaking because the hot water thermal recovery and the space heating thermal recovery operate in series. Thus, the energy available for space heating thermal recovery is the balance from the thermal recovery input after hot water heating is deducted. Also, the number of hours that space heating thermal recovery can be used a year is a function of local climatic conditions and the residence's thermal demand at specific outdoor temperatures. Moreover, fuel savings are a function of the type of heating fuel and the system using that fuel.

As a result, special CRN tool kit software has been developed to calculate space heating annual cost savings. First, the residual energy available for space heating needs to be calculated. This computation uses a number of inputs, including gallons of hot water used per day, water heater inlet and outlet temperatures, water heating fuel efficiency, and percentage of water heating supplied by the thermal recovery loop. The resulting average daily water heating thermal recovery use is calculated and then subtracted from the fuel cell's available thermal recovery to yield the energy available for space heating.

Space heating inputs include the residence's design heat loss at 0°F as well as the temperature at which heating begins after deduction for the effects of solar and internal heat gains. Using this data, heating requirements are calculated for 5°F ambient outdoor temperature interval bins. These bins are concurrently populated with the number of hours a year that the outdoor temperature is within the bin range. Although specific data can be entered, users can toggle input to select climatic temperature bin data for Atlanta, Georgia, or Columbus, Ohio. These are two locations often used for benchmark analysis in the heating, ventilation, and air conditioning industry.

Table 7. Space Heating Thermal Recovery Savings and Allowable Capital Costs

Location and Space Heating System	Thermal Recovery Savings		Maximum Economic Thermal Recovery Installed Cost
	Mil Btu/Yr	Dollars/Year	
Atlanta, Georgia			
Heat Pump			
Electric Water Heating at \$0.06	18.8	\$380	\$2,460
Space Heating at \$0.06	8.0	140	900
Total	26.8	\$520	\$3,360
Propane Furnace			
Electric Water Heating at \$0.06	18.2	\$380	\$2,460
Space Heating at \$1.15/gal	28.2	340	2,170
Total	47.0	\$720	\$4,630
Propane Furnace			
Propane Water Heating at \$1.15/gal	27.0	\$760	\$4,920
Space Heating at \$1.15/gal	28.2	340	2,170
Total	45.2	\$1,100	\$7,090
Electric Resistance Heating			
Electric Water Heating at \$0.06	18.8	\$380	\$2,460
Space Heating at \$0.045	21.1	280	1,790
Total	26.8	\$720	\$4,250
Columbus, Ohio			
Heat Pump			
Electric Water Heating at \$0.06	18.8	\$380	\$2,460
Space Heating at \$0.06	34.5	610	3,890
Total	26.8	\$990	\$6,350
Natural Gas Furnace			
Water Heating at \$7/Mil Btu	27.0	\$450	\$2,870
Space Heating at \$7/Mil Btu	46.0	320	2,060
Total	63.0	\$770	\$4,930
Propane Furnace			
Electric Water Heating at \$0.06	18.8	\$380	\$2,460
Space Heating at \$1.15/gal	46.0	550	3,550
Total	64.8	\$930	\$6,010

Note: The standard dwelling in this analysis is two-story and 2,000 ft² with a length-to-width ratio of 2:1 and 14% double-glazed glass in the walls. The dwelling is built to electric heating standards, with 5.3 in. of wall insulation and 8 in. of ceiling insulation. Air changes are 0.7 per hour. The calculated heat loss is 36,010 Btu at 0°F using a 65° F balance point temperature. Fuel choices for water heating and space heating are as noted. Hot water use is 80 gal per day at an 80°F rise with 90% from fuel cell thermal recovery. Fuel cell thermal recovery potential is 10,000 Btu per hour. Thermal recovery savings in million Btu per year are *after* the effect of equipment efficiencies. Maximum economic thermal recovery installed cost is based on a 10-year life at 9% cost of capital.

Users then select a fuel and heating system and fuel cost. Temperature-based heating efficiency curves are available for gas or propane furnaces; heat pumps, including supplemental heaters; and electric resistance heating. After the user selects the outdoor temperature “unlock” setpoint for the thermal recovery three-way valve, the software computes the available thermal recovery that can be used within each temperature bin. Related temperature-dependent fuel efficiencies for the space heating system are then used to calculate the fuel that could be saved for each temperature period. These results determine average annual savings for the particular system and operating configuration selected for analysis. Based on equipment life and debt rate entries, the program also calculates the maximum allowable cost that could then be spent to install the space heating thermal recovery.

4.5.4 Conclusions

With the exception of the Atlanta heat pump, all of the space heating thermal recovery savings are in the range or \$300 or more per year. This yields allowable maximum economic thermal recovery installation costs for the space heating portion in the \$2,000-dollar range. In comparison, the estimated installation cost is \$2,070 before any cost-reduction tuning. If the equipment life remains at 10 years but the cost of capital is reduced from 10% to 7%, the allowable installation cost increases by about 10%. Somewhat surprisingly, even the Columbus gas furnace is in the same \$300 thermal savings range even though natural gas at \$7/million Btu would generally be considered a relatively cheap fuel.

The innovative use of a separate control system rather than coupling the space heating thermal recovery to gas burner operation of the gas furnace is justified because gas furnace operating hours are less than available climatic heating hours. The reason is gas furnace output must be selected for a worst-case design point, a high heating load such as 0°F to -10°F. Thus, normal furnace operation at the warmer average winter temperatures, or mild weather heat pump use, is for relatively short periods of time. The furnace then shuts off until the dwelling indoor temperature again drops. Based on both Atlanta and Columbus climatic data, if the space heating thermal recovery were operating with the furnace burner, space heating thermal recovery would decline by 70%–75%. Instead of \$300–\$500 annual space heating savings, the results would be only \$90–\$150 annually and could not support the incremental added installed cost for the space heating portion of fuel cell thermal recovery.

An additional encouraging factor is the complementary nature of the hot water heating and space heating thermal recoveries. Hot water heater loads are most likely to occur during daylight hours, most particularly in the morning to mid-day. In contrast, space-heating loads are most likely to occur late in the day and at night. This is for several reasons. First, a typical diurnal temperature swing of about 12°F exists between warmer daylight and cooler nighttime ambients. Second, solar heat gains generally couple with internal heat gains from occupants and appliances to add about 5°F–10°F to the dwelling’s daytime temperature. This is the reason for the balance point described earlier in the software. The fortunate end result is that space heating needs for thermal recovery are more likely to be at night and are counter-cyclical with normal hot water heating needs.

To some extent, even the Atlanta heat pump might prove attractive if combined with the Bradford White CombiCor indirect thermal recovery system. This is because this gas water heater burner is large enough to provide the Atlanta customer's hydronic furnace coil with relatively normal emergency space heating even when the grid has an extended outage and the on-site fuel cell is not large enough to run the dwelling's 240-V, 3–4 kW heat pump compressor.

4.6 Thermal Recovery Heat Transfer Assessment

Controlling thermal recovery loop flow is important if suitably high temperatures are to be maintained at the heat transfer surfaces for the water heater. Given a constant inlet temperature to the fuel cell's heat exchanger, the fuel cell is assumed to supply a constant thermal transfer in British thermal units per hour, irrespective of the loop flow within a reasonable range. Thus, the strategy to secure an acceptable heated water temperature has been to reduce the loop flow rate, thereby driving return flow temperature higher. For example, hot water is more useful to the consumer if it comes at a 140°F fuel cell supply than at a 100°F fuel cell loop thermal recovery temperature.

In fact, even though heat transfer appears to be a simple operation, the underpinnings are complex. For heat transfer to a liquid, the amount of heat that can be transferred depends on the driving force (temperature difference between the fuel cell and loop sides) and the thermal resistance to that heat flow. For example, the water in the pipe parts of a heat exchanger tends to form a boundary layer next to the pipe wall and has 600 times as much resistance to heat transfer as does the copper of the pipe wall.

A typical profile is shown in Figure 28 for heat transfer from the thermal recovery loop's copper pipe to the liquid in the water heater. The vertical axis shows the temperature at various points for the heat flow; the horizontal axis, shows the various components as relative distances. The system consists of a copper tube containing thermal recovery circulating fluid. The tube is wound around the water heater's external wall with heat transfer enhanced by a conductive paste. The water heater itself has a steel wall with a thin porcelain glass liner. Large vertical drops on the graph indicate large temperature differences and therefore relatively high resistance to heat transfer across that region.

As indicated on the graph, the major resistance is the boundary layer of the water itself inside the tank. Indeed, the tank is actually designed to maintain a thermocline with hot water on the top and cold makeup water from the dip tube on the bottom. Because the water circulation inside the tank is only by slow convective currents and water is much less conductive than metal, a great deal of the heat transfer resistance is the layer of water against the tank wall. Unfortunately, little manufacturer or even solar industry data are readily available to estimate heat transfer flows within the systems.

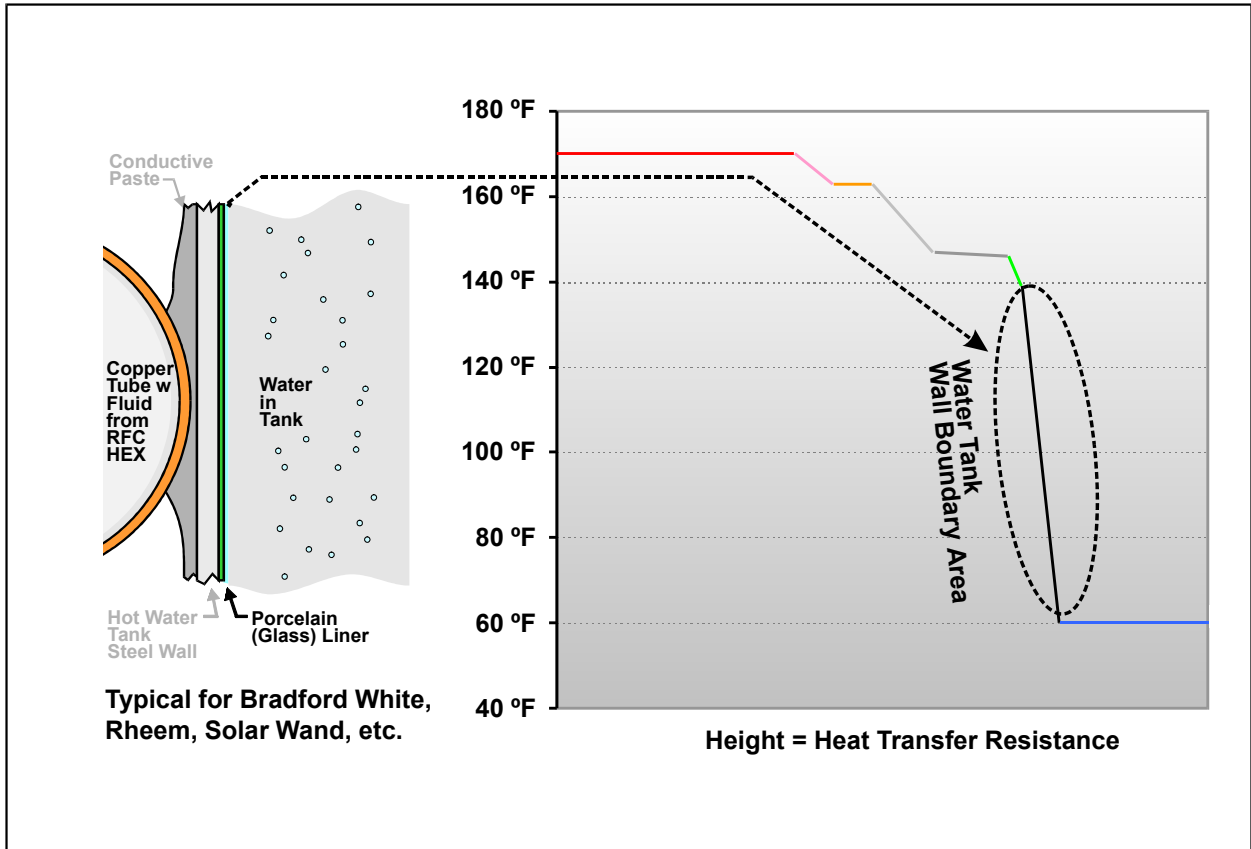

Figure 28. Heat transfer from thermal recovery loop to water heater

Nonetheless, to evaluate systems and develop cost-effective thermal recovery designs, it is important to understand the issues. As a result, a standard thermal recovery design has been developed that consists of a copper coil brazed to the wall of a hot water tank. Using this reference configuration, various systems can be “graded” using comparative heat transfer calculations embedding available data and reasonable approximations. The resulting engineering assessments consider two factors. The first is how the heat transfer per square foot of surface likely compares with a brazed copper tube on the exterior wall of a bare water heater tank wall containing no internal porcelain layer. The second factor is the square feet of the actual heat exchange in the system under consideration. The two factors together yield comparative heat transfer ratings.

The results indicate little difference between the internal and external tank coil systems because both have essentially the same 10-ft² heat exchange surface to the potable water in the hot water tank. As expected, turbulent flow on both sides of an external U-shaped heat exchanger significantly enhances the effective physical heat exchange surface by a factor of about seven, giving an equivalent tank surface of around 18 ft². Of course, this occurs at the expense and complexity of an added circulating pump. Analysis of the System 3 tank insert device is still under way, but preliminary data indicate it works better than its calculated area indicates.

Table 8. Comparative Hot Water Thermal Recovery Systems

Thermal Recovery System	Estimated Effective Heat Transfer Surface Referenced to a Brazed Copper Tube on the Exterior Wall of a Hot Water Heater Tank (Square Feet)
<p>System 1: 120 ft of 3/4-in. copper tubing wound around the exterior wall of hot water tank. Conductive paste also used between the tubing and the exterior tank wall. Tank internal wall has porcelain glass protective layer. System is a double-wall, air-gap heat exchanger.</p>	10.3-ft ² equivalent surface
<p>System 2: 80 ft of 1/2-in. copper tubing internal coil with a high-density polyethylene sheath and a monofilament leak path. System is a double-wall, air-gap heat exchanger.</p>	11.1-ft ² equivalent surface
<p>System 3: 4-ft insert in water heater outlet consisting a ~1/2-in. copper flow path in a copper return sheath. Surface area is 2.2 ft². System is a double-wall, air-gap heat exchanger.</p>	3.5-ft ² equivalent surface
<p>System 4: External U-shaped shell-and-tube heat exchanger estimated at 2.3 ft² of surface. Circulation pumps provided for turbulent flow on both sides. System is a double-wall, air-gap heat exchanger.</p>	17.6-ft ² equivalent surface

4.7 Thermal Recovery System Mapping

For these reasons, the CRN RFC demonstration tool kit contains thermal mapping software for use during RFC commissioning. This software can create a map of the thermal recovery potential at various temperatures and thermal recovery loop flow rates. By providing an understanding of actual thermal recovery parameters, mapping is critical to improving thermal recovery applications and the economic benefits that are cardinal to enhanced fuel cell use.

Figure 29 shows the thermal recovery mapping software and its results for a thermal recovery field system. The thermal recovery mapping software uses a two-part process. The first segment sets the circulating loop flow rate for the best compromise among the heat transfer from the fuel cell power plant, the thermal recovery water heating availability, and the entry temperature to the water heating thermal recovery. Given a target of 140°F, the loop flow parameters are monitored as the flow is slowly increased to a set point at which the thermal recovery loop supply temperature starts to fall below 140°F.

CRN RFC Demonstration Tool Kit: Thermal Recovery Mapping Software

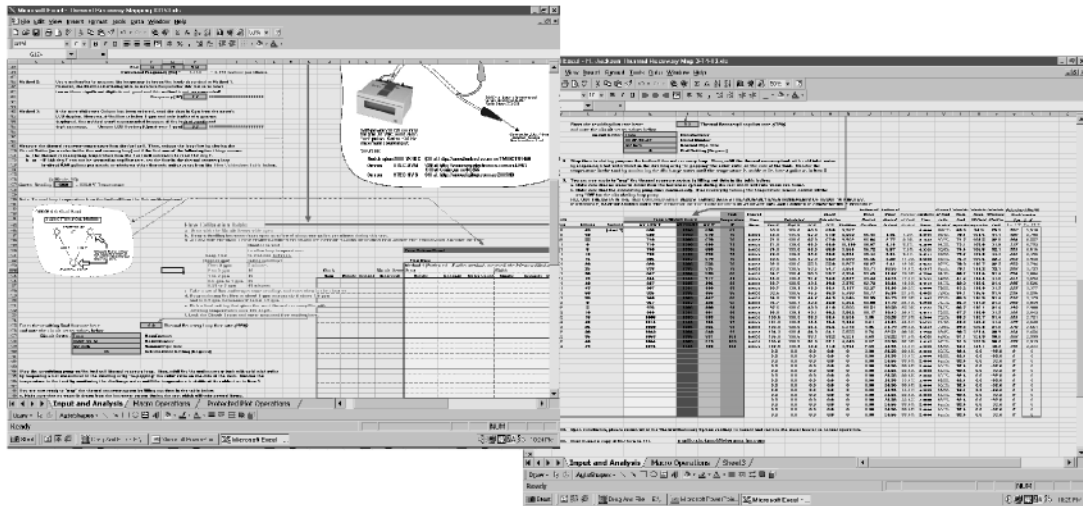

Rheem Solar Tank w External Coil

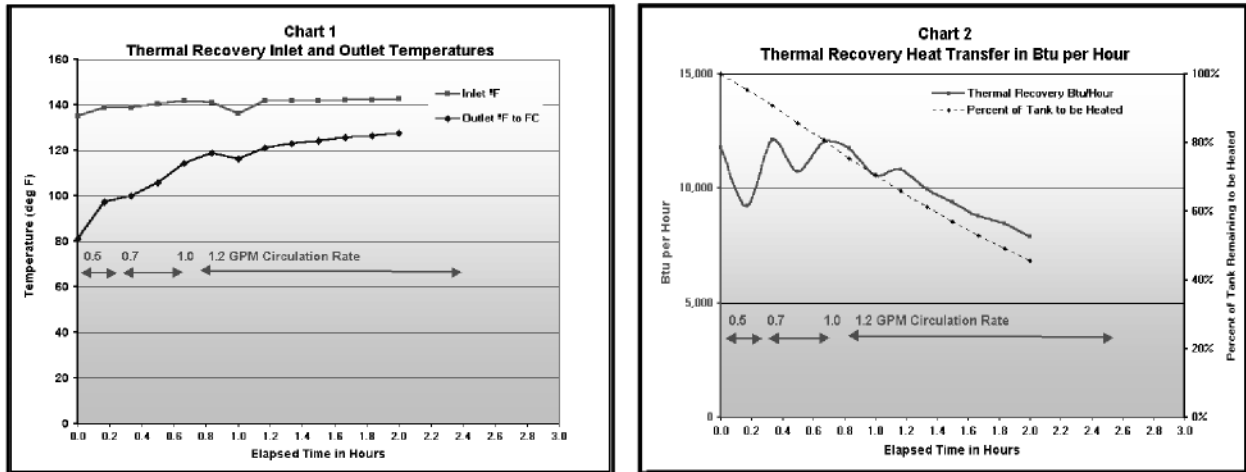

Figure 29. Thermal recovery mapping software and results

The second step assesses the supply and return temperatures in the thermal recovery loop to ascertain how these change over time as the customer’s hot water tank warms up. This is evident in the left graph, labeled Chart 1, which shows how the fuel cell supply temperature to the heat exchange has remained stable. However, the return temperature back to the fuel cell continues to rise as the hot water tank warms. Because the loop flow is fixed, this differential affects the available thermal recovery shown by the solid line on Chart 2. This initially remained relatively stable as the thermal recovery loop’s flow rate was increased from 0.5 to 1.2 gal/min. However, after the loop flow was set to a constant value and the customer’s water tank continued to warm up, the heat transfer declined from some 11,000 Btu/hour to around 7,500 Btu/hour when only the last 45% of the customer’s 80-gal tank remained to be heated.

This depth of analysis is important for understanding the complex interaction between the hot water heating thermal recovery system and the heat exchange that provides this energy to the customer from the fuel cell power plant. This ultimately enables the best choice and tuning of systems to maximize thermal recovery benefits within acceptable installation costs. Although thermal recovery is probably not as intellectually interesting and has not received the attention of grid electrical interconnects, good thermal recovery application is just as key to the RFC's implementation success.

4.8 Reducing Thermal Recovery Costs

4.8.1 Background

A goal of the CRN RFC demonstration program is to assess and enhance RFCs as a viable DG candidate. Thus, installation costs are an important factor. Installation expense and complexity affect successful RFC acceptance just as initial power plant purchase pricing does. Efforts are under way to benchmark and improve all RFC interconnection costs, including electrical grid and thermal recovery installation.

For thermal recovery, two segments are crucial. Thermal recovery attractiveness is essentially the fuel value of energy savings offsets compared with the cost of installing the thermal recovery system. The first part of the effort is epitomized by the intensive evaluations of hot water thermal recovery systems and the potential for space heating fuel offsets. The second part, described below, is reducing the general costs of installed thermal recovery systems.

4.8.2 Reduced Components and Materials Costs

An extensive effort is under way within the CRN RFC demonstration program to explore the costs of various systems, including direct and indirect thermal recovery and manufacturers' equipment selections. Complementary efforts are aimed at reducing the costs of materials and labor for these target thermal recovery systems. Figure 30 assesses the possibility of using smaller-diameter, easier-to-install flexible interconnect tubing. It assesses the pressure drop of the 120 ft of 3/4-in. tubing in the external coil in the Rheem System 2 and of the 80 ft of 1/2-in. tubing in the internal coil Bradford White System 3 when combined with the thermal recovery loop's own tubing. The latter is 16 ft of 3/4-in. tubing and fittings around the hot water heater combined with 60 ft of tubing with related fittings between the hot water heater and the fuel cell power plant.

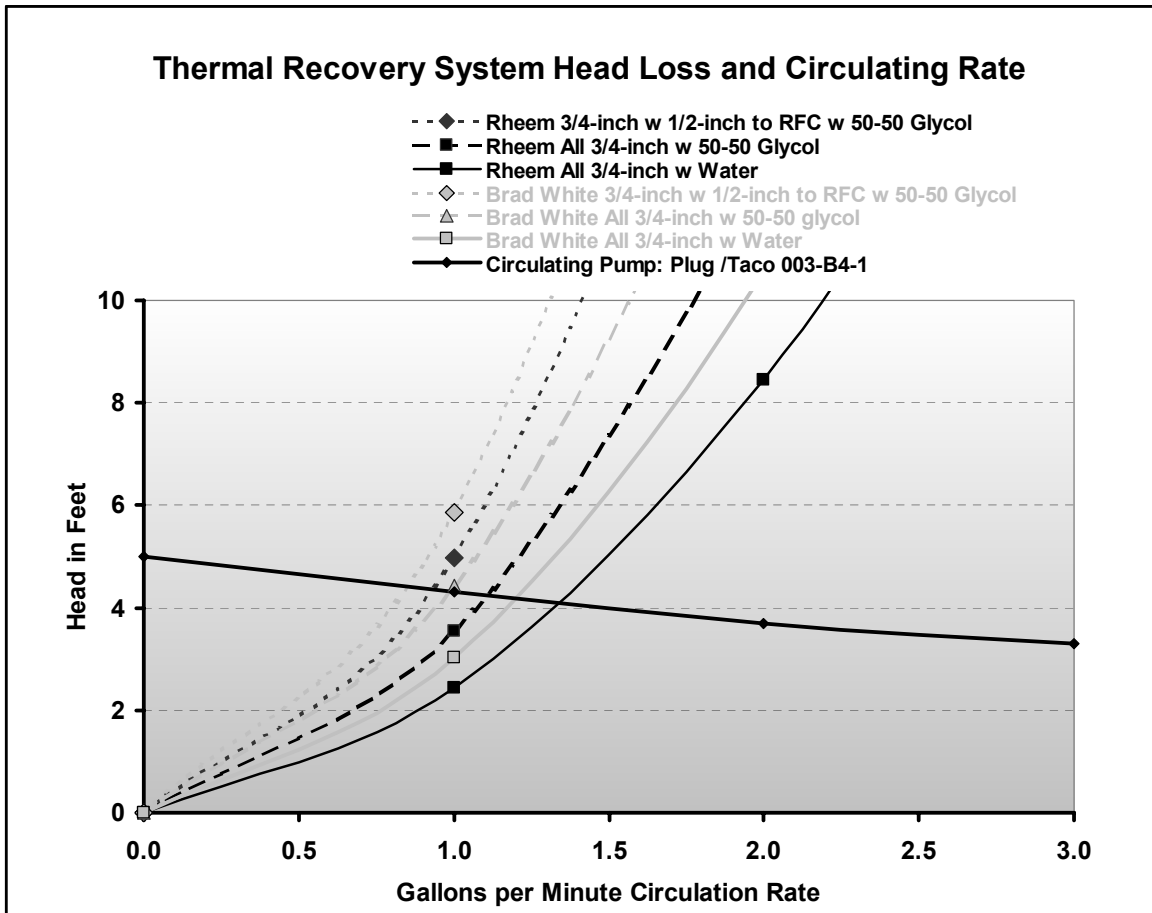

Figure 30. Thermal recovery piping and circulating pump flow curves

The composite operating chart shows the relationship between the circulating pump and the overall thermal recovery loop, including the interconnection tubing. The vertical axis shows the head loss in the system. This is typically expressed in feet for hydronic systems because 1 ft of water is equivalent to a 0.433 psig pressure drop. The horizontal axis shows the circulation rate of the system. The piping and fluid curves all trend upward and to the right from zero flow. Because pressure drop in a pipe is related to the square of the flow velocity, the pressure drops in the system increase significantly as the circulating flow increases. Pressure drops are shown for both 3/4-in. interconnecting tubing and 1/2-in. tubing. These are essentially plumbing tubing, and the nominal sizes refer to inside diameter, which means that the 1/2-in. tubing is equivalent to 5/8-in. refrigeration tubing. Pressure drops are also shown for water and a 50-50 antifreeze mixture of propylene glycol and water.

Superimposed on these pressure drop calculations is the circulating pump curve. When the pump starts, the loop's flow rate will increase until the pump head just matches the related pressure drop. Thus, the reason for the circuit setter shown on the earlier system drawings is to add enough controlled pressure drop in the piping to "set" a desired thermal recovery loop flow rate. A reason for considering the smaller 1/2-in. tubing for interconnection is that it is available in pre-insulated rolls that are easier and less expensive to install in the field than the larger 3/4-in. rigid, uninsulated tubing. The latter has numerous soldered fittings and requires hand-applied insulation.

The closeness of the pressure drop curves demonstrates there is little practical difference in the pressure drops and that pre-insulated, 1/2-in., flexible tubing should be acceptable. This is the equivalent of commonly used 5/8-in. refrigeration tubing. Labor savings are projected to be 5.5 hours or \$360 for each of the "standard" fuel cell installations used in the earlier thermal recovery system comparisons.

Other examples are more mundane. These include finding a suitable control system that is commercially available and mass-produced (rather than a site-built controller specified by one of the fuel cell manufacturers). The end result is the specification of a commonly available power supply and fan control relay used in residential heating systems. The result, already incorporated in the system costs described in this section, is a savings of more than \$200 in site labor.

4.8.3 Reduced Installation Labor Costs

4.8.3.1 Improved Installation Guides

For typical fuel cell thermal recovery installations at residential sites, field labor represents \$2,000 to as much as \$3,500 and is 65%–75% of the thermal recovery cost. Labor is usually even higher for residential demonstration units when plumbers and electricians are not familiar with the technology.

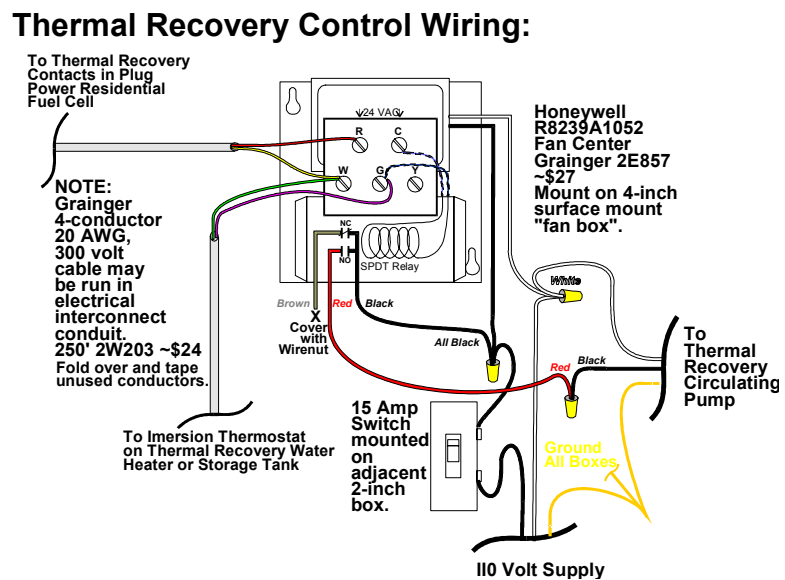

Figure 31. Commercially available thermal recovery controller

Targeted educational efforts are under way to reduce installer uncertainties and excess site labor. These efforts are two-fold and encompass both fuel cell manufacturers and site installation personnel:

- Manufacturers have been asked to consider providing step-by-step installation sketches like those received with a replacement dishwasher or water heater. One example of this type of material is Figure 31, which shows the installation of the thermal recovery circulating pump control. Other examples, which would need enhancement of close-up details, are the thermal recovery system sketches shown in figures 24 through 27.
- Logan Energy has suggested videotaping a complete installation. This could be used by plumbers and electricians at future installations to enhance their comfort level with otherwise unfamiliar technology.

Improved installation guides and informational sketches can help bridge the gap to contractor experience and reduce costs of initial RFC electrical and thermal recovery installations.

4.8.3.2 Component Supply and Preassembly

Thermal recovery and site labor costs are based on “stick built” residential installations. This means that the local contractor has to include all the hours associated with securing the individual parts from various sources, determining how they are to be connected together, and then assembling them on site by cutting and soldering.

For example, all thermal recovery systems have the following parts:

- On the return, cold side of the hot water heater or space heating system that returns loop flow to the fuel cell:
 - Drain port
 - Isolation valve
 - Fill port
 - Union
 - Circulating pump inlet screen
 - Circulating pump
 - Circuit setter (flow setting valve)
 - Cold-side Thermowell (for demo sites)
 - British thermal unit flow meter (for demonstration sites)
 - Union
 - Isolation valve
 - Air bleed valve
- On the hot side of the loop from the fuel cell to the water heater:
 - Hot-side Thermowell
 - Air separator
 - Air bleed valve
 - Expansion tank
 - Union
 - Isolation valve.

For each of these components, it would not be unusual for an installer to need as much as 15–30 min of labor time to read the instructions, decide where and how to mount it, cut a length of 3/4-in. copper tubing, find and solder adapters on each end, and thread the parts together. Although the interconnecting tubing “jumper” between each part costs \$2.05 in materials, its labor can be \$15–\$30. In contrast, a prepurchased threaded brass nipple costs about the same but only requires about \$5 of labor for the same connection.

Thus, one of the efforts under way is to identify a standard installation “stick” assembly for the cold and hot ends of the thermal recovery loop, particularly for more common systems such as the add-on solar tank shown. A detailed “dishwasher installation-like” sketch would show the parts and the pre-selected fittings for connecting them together in sequence. The sketch could be accompanied by a box of pre-supplied parts and fittings, or the ends could be assembled elsewhere in advance of the site work.

It is unlikely that the manufacturer could integrate many, if any, of these components into the fuel cell power plant. Space and service access are limiting, and there are inherent differences among thermal recovery concepts from site to site. However, with proper site installation preplanning and possibly even prefabrication, the procedures being developed should provide a useful equivalent. The result should save as much as 6–8 hours of installation labor totaling \$400–\$500. Moreover, additional savings would likely occur from direct parts purchases, which avoid local markups and resolve the issue of parts not being locally available.

4.8.3.3 Conclusion

Coordinated efforts are under way through the CRN RFC demonstration program to enhance the potential for fuel cell thermal recovery at residential dwellings and reduce the installed costs of the systems. Progress is being made on both fronts.

5 Natural Gas and Propane Fuel Supply

5.1 Standard Metering Installation

5.1.1 Background

Fuel supply interconnection and metering for the RFC demonstration sites has been straightforward, and no significant issues are evident from the field demonstrations. Figure 32 depicts the revised standard installation guideline, which includes a meter pulse output for data logging as well as a pressure gauge and a fuel-sampling port.

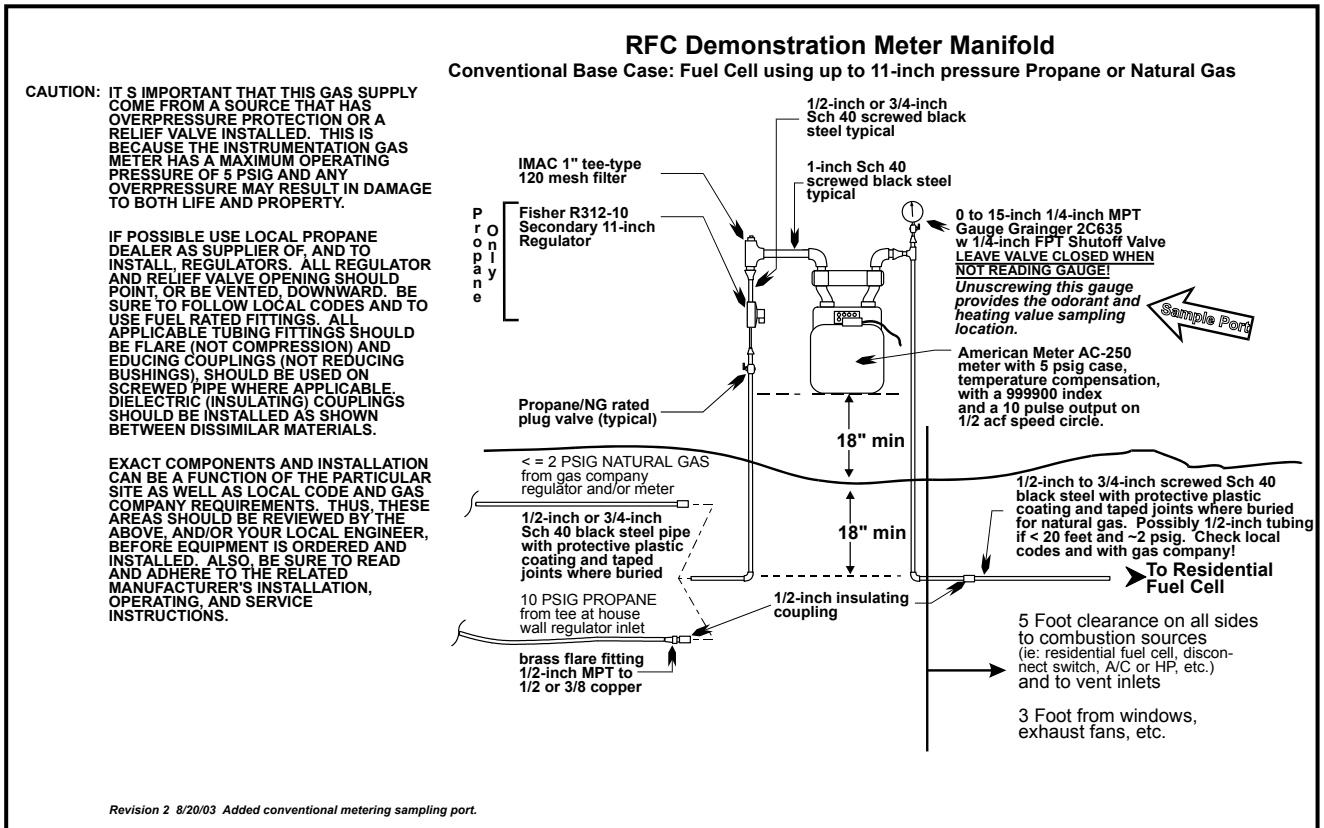

Figure 32. Standard residential fuel cell fuel supply metering

Despite their apparent simplicity, natural gas meters are well-developed devices yielding an accuracy equal to, or better than, 1%. Natural gas itself is principally composed of methane (CH₄) but includes relatively low percentages of higher hydrocarbons such as ethane and other possible diluents such as carbon dioxide and nitrogen. Although liquefied petroleum gas (LPG) is commonly referred to as “propane,” it universally represents a mixture of propane (C₃H₈) and higher hydrocarbons such as butane (C₄H₁₀). The better “commercial propane” grade of LPG is called HD5. This mixture is 95% propane and 5% butanes and is the LPG grade typically specified by RFC manufacturers for their equipment. This HD5 version of LPG has a typical energy content, or higher heating value, of around 2,560 Btu per standard cubic foot (SCF). However, this energy content can change markedly depending on the actual amount of butane present at the fill and how the liquid “boils off” during tank drawdown.

In contrast to propane, natural gas has smaller hydrocarbon molecules and, thus, a correspondingly reduced energy content of around 1,000 Btu/SCF. A standard cubic foot is 1 ft³ of dry gas at 60°F and 30 in. of mercury pressure, which is 14.73 pounds per square inch absolute pressure (psia). Atmospheric pressure at sea level is 14.696 psia. Even though natural gas has less energy per cubic foot, its overall cost is \$6–\$7/million Btu of energy. In contrast, propane at \$1/gal would cost \$10.95/million Btu, or about twice as much for the same amount of RFC energy.

Two types of natural gas meters are in common commercial use: rotary turbine and positive displacement. Provided that the gas flowing through the meter is medium- to low-pressure, positive displacement meters are generally less expensive, easier to install, and have a greater turndown ratio. Thus, positive displacement, often called diaphragm, meters are the first choice for this residential demonstration program. These meters are quite accurate when internal temperature compensation is specified and relatively inexpensive and trouble-free. Gas meters are essentially an “actual cubic foot” measuring device. Because natural gas and LPG/propane are for all practical purposes an ideal gas at these temperatures and working pressures, their metering is subject to the normal gas law in which PV/T equals a constant. This means both pressure and temperature can influence the output readings of a demonstration site’s gas meter.

5.1.2 Demonstration Program Pressure and Temperature Correction Need

Before leaving the factory, gas meters can be proof-tested and calibrated to a pressure of 14.73 psia. The standard condition at which natural gas is measured is 14.73 psia at 60°F. This is essentially a 4-oz flowing pressure through the meter at an elevation of 470 ft, where it is assumed the average gas customer resides. Thus, for fuel-to-electric efficiency measurement accuracy, any demonstration gas meter needs to be corrected for the gauge pressure that is flowing through the meter and the absolute normal air pressure at the elevation where the meter is installed.

Gauge pressure (psig) is measured by an ordinary round pressure gauge like that used to measure tire or water pressure. Normal atmospheric pressure changes with elevation and is 14.696 psia at sea level. The National Oceanic and Atmospheric Administration has tables of “normal” atmospheric pressure in inches of mercury for any elevation above sea level. Site elevation can be easily determined using the <http://teraserver-usa.com/address.aspx> site. The calculation of this correction factor is now made automatically within the CRN RFC demonstration tool kit by the Rfc_Monthly_Meter_Reading.xls spreadsheet when site altitude is entered into the master data.

The effect of temperature on gas meter readings is significant but difficult to ascertain without temperature measurement in the field. This is because the temperature of the gas flowing through the meter is somewhere in a band stretching from vaporized propane temperature through soil temperature to ambient air temperature. As is the case with pressure, the effect is based on the ratios of the absolute temperatures relative to a measurement standard of 60°F for natural gas metering. Absolute temperature is measured in degrees Rankine and calculated as °R = 460 + °F.

For example, at 100°F the meter will read almost 8% fast. Conversely, at -10°F the meter will be slow by more than 13%. Although it is possible to compensate for temperatures by electronic measurement and integration, the most practical and cost-effective solution for this type of demonstration program is to purchase temperature-compensated meters as indicated in the CRN RFC demonstration tool kit metering guidelines. These use a bimetal linkage, much like the pendulum on accurate mechanical clocks, to automatically compensate for temperature by changing the rate of the meter's odometer. These meters have an accuracy of plus or minus 1% or better over a broad temperature range and ensure that flow pulse counts, monthly volume readings, and calculated efficiencies will be accurate.

5.2 Lower Versus Higher Heating Value

5.2.1 Importance

Significant misunderstanding exists about fuel cell efficiency and data specified on a lower heating value basis. The section adapted below was developed for widespread distribution to co-ops as part of the CRN microturbine and RFC demonstration program to highlight these concerns and stress the importance of proper reporting and analysis protocols.

Calculating Fuel Use for Microturbines or Fuel Cells—Without Getting Shortchanged

To evaluate the economics of an RFC installation, co-op engineers need to understand the nuances of how fuel costs and use are measured. Natural gas, propane, oil, and coal all are sold by volume or weight with their energy content noted on an HHV basis. But when determining, for example, the cost of electricity from an RFC, it is necessary to know the cost of the fuel on the same energy basis the manufacturer uses to state the unit's efficiency.

Although we all know that British thermal units are a common measure of energy, most of us don't normally care that when we buy a cubic foot of natural gas or a gallon of propane we actually have fewer British thermal units when measured on a LHV basis than when measured on an HHV basis. What is this LHV and HHV alphabet soup, why does it exist, and why do you need to know? For the answers, read on.

Fuel Cells, Microturbines, Combustion Turbines, and Why They Typically Use LHV

Fuel cell and microturbine manufacturers typically quote their efficiency in terms of "lower heating value" (LHV) because LHV best represents the true useful energy in fuel. On the other hand, fuels are priced and analyzed according to "higher heating value" (HHV). This difference can cause an underestimation of fuel use by as much as 10% if LHV equipment efficiencies are inadvertently mixed with HHV fuel energy contents.

When a hydrocarbon fuel—including coal—is burned, the combustion products are carbon dioxide and water vapor. Essentially, the carbon in the fuel combines with oxygen in the air to make CO_2 ; the hydrogen in the fuel molecule makes H_2O . When this combustion product is allowed to condense to a liquid, the measured heating value is called HHV. This is often expressed in British thermal units per pound for coal, per gallon for propane or fuel oil, and per cubic foot for natural gas. When this water is in vapor form, the heating value is called LHV, and the British thermal units are less. If a manufacturer says the efficiency of a fuel cell or microturbine is, say, 32% LHV, it means that 32% of the fuel British thermal units *when measured on a lower heating value basis* will be converted into electricity by the device. On the other hand, if the device is said to have an efficiency of 32% HHV, then 32% of the higher heating value British thermal units will be converted into electricity. To make things even more messy, common gas appliances such as furnaces and water heaters always have their efficiencies quoted on an HHV basis.

Natural Gas and Why HHV Got Started

Natural gas supplied by a utility is 80%–95% methane (CH_4). It also contains some ethane, propane, nitrogen, and CO_2 . So the energy value of natural gas can range 950–1,130 Btu/ft³ HHV. (A British thermal unit is the energy it takes to raise one pound of water 1°F.) Most gas utilities sell natural gas by million Btu HHV.

The energy content of natural gas and other fuels historically was measured by water bath calorimeters. When natural gas burns, this happens: $\text{CH}_4 + \text{air}$ produces $\text{CO}_2 + 2\text{H}_2\text{O}$. The H_2O appears as water vapor in the combustion products but is condensed at the calorimeter's water bath temperature. This conversion of water vapor to liquid releases more heat. This is the reverse of the process of having to continue to apply heat to a teakettle or a boiler to keep converting its water to steam. LHV, on the other hand, does not count the energy of condensing the gas flame's water vapor into liquid water.

If you call your gas company or propane dealer and ask how many British thermal units of energy are in a cubic foot of gas coming from the meter or in a gallon in your tank, they will universally tell you a number that is HHV-based. In most instances, offhand, they won't even know the LHV British thermal units.

A typical natural gas might have an HHV of 1,045 Btu/ft³ and a corresponding LHV of 943 Btu/ft³. If those figures were confused, or reversed, it would result in a fuel use error of more than 10% for microturbines and fuel cells.

For example, given the above cubic foot of natural gas, if the manufacturer reports an efficiency of 32% LHV and that figure is multiplied by 1,045 HHV, the result would appear to be 334.4 Btu of electricity produced, or about 0.098 kWh for each cubic foot of natural gas put into the machine. In fact, the actual amount of electricity that would be generated—correctly figured at 943 LHV x 32%—comes out to 301.8 Btu, or about 0.088 kWh. In other words, when the LHV efficiency was mixed with the typically used HHV, we and the manufacturer each made different assumptions about the amount of useful energy in a cubic foot of natural gas (1,045 Btu HHV by us and 943 Btu LHV by the manufacturer).

LPG, Propane, and What's What

LPG (liquefied petroleum gas) is a byproduct of natural gas production or refinery operation. It contains chain hydrocarbon gasses that condense to a liquid at ordinary temperatures and modest pressures. Although LPG is commonly referred to as—and often is confused with—propane (C_3H_8), it can also contain such things as propylene (C_3H_6) and a fair amount of butane (C_4H_{10}). The propane the public buys is a subset of LPG that contains fewer of these non-propane ingredients. Fuel cells are typically specified to use HD5 propane, which contains at least 90% and quite often 95% propane. Incidentally, like natural gas, LPG and propane don't smell, so the distributor adds an odorant such as ethyl mercaptan (CH_3SH , where S is sulfur). Mercaptan has to be absorbed by a chemical bed inside a fuel cell so that the sulfur doesn't poison the cell stack or fuel processor catalysts.

HD5 propane, which is 95% propane and 5% butane, has an HHV of about 92,200 Btu/gal and an LHV of 84,850 Btu/gal. The fuel industry universally uses HHV; microturbine and fuel cell manufacturers are equally intent on using LHV to describe efficiency, perhaps to some degree because the resulting number is more impressive.

For a co-op planner, the easiest solution is to convert any manufacturer's stated LHV efficiency into an HHV efficiency and then use quoted fuel prices. To do this, simply divide any LHV efficiency by the HHV-to-LHV ratio of the fuel. For example, the ratio of HHV to LHV for the above HD5 propane is ($92,200 / 84,850$) 1.087. This is the LHV efficiency correction divisor for a fuel cell or microturbine running on propane. For a natural gas machine, this correction factor is calculated the same way, but the answer is more like 1.1, depending on the exact natural gas composition.

Also, it is often useful to convert propane costs from cents per gallon into dollars per million British thermal units so that they can be compared with other fuel costs. To convert cents per gallon HD5 propane into dollars per million British thermal unit HHV, multiply the cents per gallon by 0.1085. Thus, 115¢/gal HD5 propane is equivalent to \$12.48 natural gas per million Btu HHV.

How to Avoid the LHV-HHV Trap

- Make sure you know whether a manufacturer is quoting efficiency on an LHV or HHV basis.
- Always convert efficiencies stated as LHV to their HHV basis and note on your analysis why and how you did it.
- Get in the habit, at least when dealing with microturbines and fuel cells, of always marking LHV or HHV after efficiencies or heat rates.

The bottom line assuming 115¢ HD5 propane
Fuel cost/Btu = 115¢/gal x 0.1085 = \$12.48/million Btu HHV = 0.001248¢/Btu HHV

For a 32%-LHV-efficient PEM fuel cell:

$$\eta_{\text{HHV}} = 32\% / 1.087 = 29.4\% \text{ HHV}$$

$$\text{¢/kWh} = [3412.6 \text{ Btu/kWh} / 29.5\% \text{ efficiency HHV}] \times 0.001248\text{¢/Btu HHV} = 14.5\text{¢/kWh}$$

For a 40%-LHV-efficient solid oxide fuel cell:

$$\eta_{\text{HHV}} = 40\% / 1.087 = 36.8\% \text{ HHV}$$

$$\text{¢/kWh} = [3412.6 \text{ Btu/kWh} / 36.8\% \text{ efficiency HHV}] \times 0.001248\text{¢/Btu HHV} = 11.6\text{¢/kWh}$$

Note: These costs do not include the benefit of thermal recovery from the fuel cell for water heating. For a co-op customer with a 2-kW average annual load that uses electric or propane water heating, the thermal recovery credit could be as much as 2.5¢ per kilowatt-hour, bringing the solid oxide unit's effective fuel cost down to about 9¢ per kilowatt-hour.

5.2.2 Field Sampling Need

Knowing the higher and lower heating values with reasonable accuracy is essential to measuring the actual efficiency of RFCs operating in field demonstrations. Energy output can be readily measured by a conventional electric meter. However, energy input is more complex. Propane/LPG, in particular, if not properly done is subject to significant error. For this reason, extensive guidelines have been developed as part of the CRN RFC demonstration tool kit. These are needed because the energy input is determined by multiplying the metered fuel flow in standard cubic feet by the heating value of the fuel, which is always given as British thermal units per standard cubic foot. A supplemental concern, particularly with propane, is that variable sulfur-bearing odorant levels can prematurely saturate removal cartridges and thereby cause irreversible damage to sensitive catalysts in the RFC's fuel processing and cell stack components.

For natural gas, the procedures are fairly simple. Natural gas compositions, heating values, and odorant levels can usually be obtained from the local gas company. These are generally good enough, but the guidelines do call for spot-checking the British thermal unit level at the time the unit is commissioned. Propane/LPG heating values can vary in British thermal unit content even if HD5-quality propane is specified, as is typically the case with fuel cell manufacturers. HD5 is a fuel that contains at least 95% propane and no more than 5% butane.

There are two reasons for heating value variations. The first is that the mixture delivered to the site might not exactly be HD5 specification and, even if it is, there can still be a heating value variation depending on whether the mix is close to 5% butane or somewhat less. The variation occurs because butane, being a larger molecule, has more energy content per cubic foot than does propane. A quick heating value calculator has also been developed as part of the tool kit's software.

The second reason is that propane and butane, because they are different sizes of molecules, tend to “boil” at different rates in the site storage tank. Propane is the smaller molecule of the two and tends to boil off more readily than butane. Thus, the composition of the gas in the top of the tank, which is fed to the fuel cell, can vary as the site storage tank empties.

The British thermal unit sampling detailed in the CRN RFC demonstration program uses a \$50 sample cylinder from a specified supplier, Empact Analytical Systems. This pre-evacuated steel cylinder, 2 in. in diameter and 12 in. long, is connected to a pre-purged meter manifold at the propane sampling point. The cylinder is then sent back to the laboratory for analysis by a gas chromatograph, and the analysis is e-mailed back for entry into the tool kit’s monthly meter reading and analysis software.

This procedure is performed at commissioning for natural gas or propane/LPG RFC power plants. After that point, no further natural gas samples will generally be needed unless something unusual happens. However, for propane units, a sample is taken at commissioning and at each monthly meter reading for the next 3 months and at least quarterly thereafter.

5.3 Odorant Issues and Measurement

5.3.1 Introduction

Normal natural gas and propane do not “smell;” therefore, leaks may not be detected by consumers until it is too late. For safety, a distinctive-smelling gaseous compound is added in parts per million by volume. These odorants are almost universally sulfur-bearing compounds and most typically ethyl mercaptan. Ethyl mercaptan is an ideal odorant because it does not fade, is distinctively pungent, and has a suitable boiling point and vapor pressure. Unfortunately, ethyl mercaptan, like almost all odorants, contains sulfur.

Sulfur compounds will irreversibly poison the platinum catalyst inside PEM fuel cell stacks and harm the catalysts in the front-end fuel processor beds. Solid oxide units are somewhat less sensitive to sulfur compounds but will also be affected. An added concern, particularly with propane, is that variable sulfur-bearing odorant levels can prematurely saturate the fuel cell’s front-end sulfur removal cylinders and cause undetected irreversible damage. This can occur because of the amount of odorant added at the regional distribution center and because the odorant, ethyl mercaptan, is a heavier molecule. Thus, there can be less odorant than average when a tank is initially used after a refill and more than expected at the end of the tank drawdown.

Field tests of RFCs may encounter propane odorant issues because the odorant is chemically reactive and has a higher boiling point than the two principal constituents of commercial propane, which are propane and butanes. A host of interrelated issues can lead to unanticipated odorant levels in propane-operated RFCs.

These include:

- **Excess dosage**
The code requires a minimum odorant dosage of 1.5 lb of ethyl mercaptan per 10,000 gal of propane. This should average out to about 26 ppmv in the gas phase. However, many bulk terminals may dose in the 2.5–3.5 pound range to ensure sufficient odorant always exists. This can lead to proportionately higher odorant levels.
- **Odorant fade**
In a new tank that had its inside wall exposed to moist air, some internal rusting may be present. The resulting iron oxide will react with the odorant to reduce its vapor level below that occurring in an “old,” seasoned tank. This can cause demonstration or factory test sites using new propane tanks to significantly over-predict the life of fuel cell odorant removal cartridges compared with real field market conditions.
- **Excess odorant volatility**
Actual tests indicate a 6.3 ppmv odorant level for propane dosed at the 1.5-lb level. However, laboratory equilibriums data predict only 1.6 ppmv. Thus, the odorant can be more volatile when vaporized with propane than equilibrium vapor pressures alone would indicate.
- **Odorant concentration on tank drawdown**
The tank’s propane odorant boils off less rapidly during the early stages of vapor use from the tank and, therefore, concentrates in the remaining liquid phase. On the first filling of the tank, the vapor phase propane odorant level might be only 5 ppmv for the first 20% of the propane used and then rise to 18 ppmv by the 80% drawdown point. This is because the odorant and propane have differing boiling points and vapor pressure equilibriums.
- **Odorant concentration with site use aggregation**
Because the liquid in the tank acts as an odorant concentrator, repeated fillings and drawdowns will greatly increase the odorant in the residual tank liquid and, thus, in the resulting vapor that is used by the fuel cell. For example, the odorant concentration in the vapor, fuel cell use, phase might be around 10 ppmv at the 50% drawdown point for the first fill (assuming that odorant fade does not exist) and 26 ppmv at the 50% drawdown of the tenth fill when the tank has finally stabilized. Moreover, if the tank were drawn down to the 80% point after 10–20 fills, the vapor phase odorant level fed to the fuel cell could reach 45 ppm.

Thus, the levels of propane odorant that will need to be removed are far from trivial. Even at the parts-per-million levels, sulfur entering a residential power plant can easily reach 0.4–0.6 lb/year just from the ethyl mercaptan odorant in the propane or natural gas fuel.

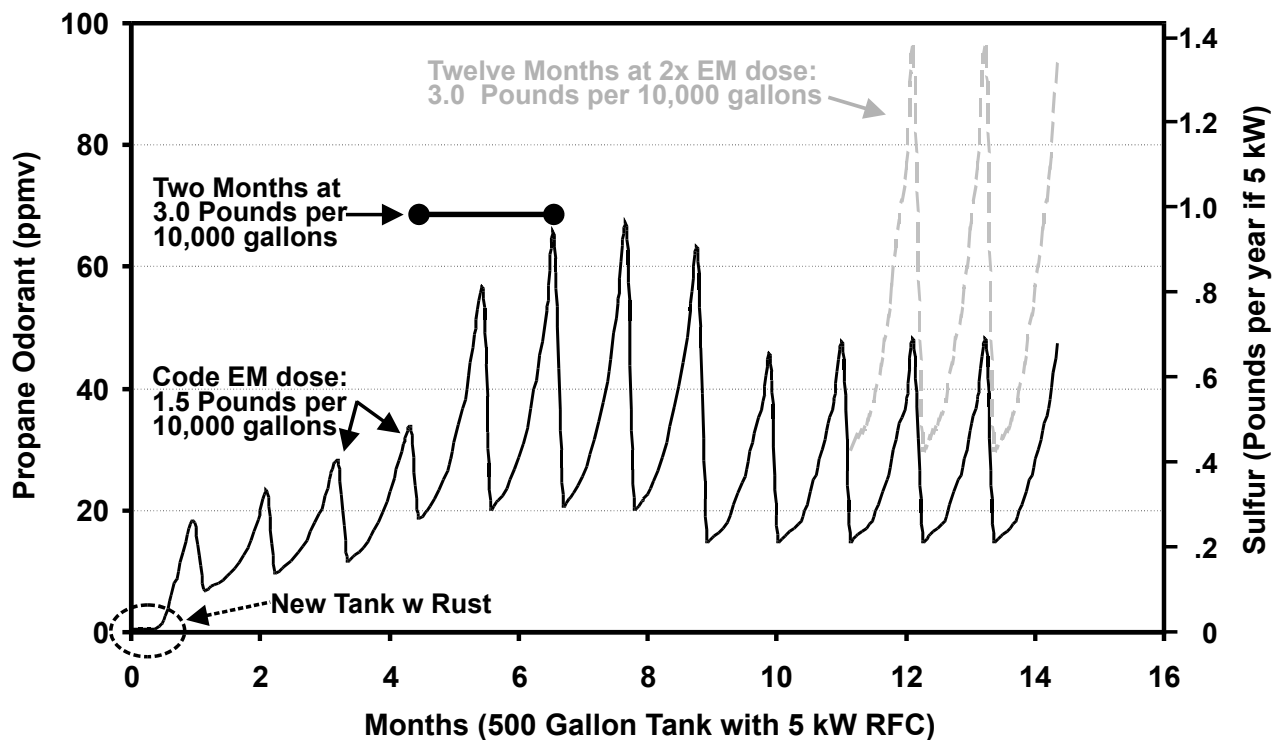

Figure 33. Potential propane odorant level changes over time

Figure 33 uses published equilibrium analyses to illustrate how the above factors can combine to yield significant changes in sulfur levels that need to be removed by the fuel cell power plant. Even given these variations and the fact that some sites will use “seasoned” propane tanks, the demonstration program’s relatively limited effort will provide valuable insight into the variations that need to be accommodated in the next generation of commercial fuel cells.

Other sulfur components, some of which can be more difficult to remove, may also be in the propane before the odorant is added. These naturally occurring sulfur species are either components of the natural gas from which the propane was separated or from oil refinery operations that produced the propane product. These other sulfur compounds can include hydrogen sulfide; its carbon dioxide hydrolysis product, carbonyl sulphide; carbon disulfide; and methyl mercaptan. There is a total sulfur specification for propane that converts to 177 ppmv. Sulfur levels in the field seem to be in the 30–50 ppmv range, but little, if any, published data exist. There is, however, a body of unpublished, anecdotal information.

5.3.2 Sulfur Odorant Removal

Several systems have historically been used to remove odorants from propane and natural gas. These range from activated carbon to copper-promoted active carbon to zeolites to special-purpose chemical scrubber beds containing copper and zinc oxides. The effectiveness of the beds is measured by two parameters. The first is residence time or space velocity (cubic feet of gas scrubbed per hour per cubic foot of bed), which measure the ability of a bed to rapidly clean gas. The second is the amount of sulfur that can be captured per pound of bed material.

RFC systems may consist of two beds, with a method for determining breakthrough. The field-sampling system developed in this section for the CRN RFC demonstration program appears quite workable. In this system, the “saturated” bed would be removed, the second bed swapped or valved to the first position, and a new cylinder added as the second bed. This is typically referred to as a “lead-lag” bed operation in the chemical industry. In any configuration or change out strategy, consideration needs to be given to related safety issues such as purging because the treated fuel gas leaving the bed is odorless.

One class of sulfur odorant removal compounds is copper and/or zinc oxide pellets. In this instance, the sulfur is chemically captured by conversion of the copper material, for example, to copper sulfide. These types of sulfur bed removal materials are manufactured by a number of major catalyst companies. Refills are generally \$5–\$7/lb but are characterized by much higher sulfur capture levels, perhaps as much as 10% or more. However, a downside is that these reactions take place far better and faster at elevated temperatures of more than 100°F. Thus, it is not clear how well, if at all, these types of beds would work with propane flowing at 0°F into a fuel cell cabinet at 30°F. Thus, some type of warming of the beds may be attractive, if not mandatory. An interesting note is that the copper content may be sufficient for the spent bed material to be processed as “copper ore” through existing relationships with bed material suppliers. Such disposal would be a marked advantage if it avoids hazardous material disposal charges, which are typically around \$1,000 a barrel.

Another class of bed materials is zeolites, with or without metal promotion. However, these generally have the cost of oxides without the same sulfur retention. One gas company indicates it has developed a zeolite material for odorant removal. An interesting characteristic is that its zeolite changes color after absorbing odorant. This suggests that, if some way can be found to seal it in a code-approved visible tube or window, it may be possible to provide a visible odorant breakthrough indicator after an odorant removal cylinder.

A third class of bed materials is carbons and metal-promoted carbons. Although less costly per pound than zeolites or metal oxides, their sulfur capture capability is lower, which raises their life cycle cost. In addition, neither are specific to sulfur compounds and may have part of their capacity taken up unpredictably by other molecules in the gas stream or even release previously captured compounds later in their life cycle.

Catalytic and related removal beds are generally designed according to residence time or space velocity parameters. Residence time refers to the time the gas remains in the bed or per foot of bed. Space velocity is the design flow rate in cubic feet of gas per hour that would pass through an equivalent bed that was a cube one foot on a side. The latter units are thus hr^{-1} . If the RFC were operating at 5 kW and 35% LHV efficiency on propane at 60°F, then about 0.0057 CFS of propane would need to be fed to the unit. These and other parameters are incorporated in a special range-finding software analysis developed within the CRN RFC demonstration.

The analysis allows for the adjustment of bed sulfur capacity and other applicable parameters. Included is an estimated cost of \$250 per cylinder change-out to cover the costs of shipping the replacement cylinder to the fuel cell service person, travel time to and from the site, labor time to change the cylinder, and shipping the spent cylinder back to the manufacturer for disposal. The preliminary results show that the apparent cheapest solution of using low-cost activated carbon is actually the most expensive when change-out shipping and labor are considered. On the other hand, the most expensive initial cost solution of using \$5–\$7/lb beds composed of copper or zinc capture material is actually the most cost effective because it avoids one or more change-outs per year, at least given the assumed design parameters.

Although odorant removal bed materials are suggested for work at “ambient” temperatures, ambient in an outdoor RFC might be a 30°F cabinet with 0°F propane flowing into the odorant removal bed. Thus, supplier tests should confirm that the beds will remove sulfur compounds at expected design efficiencies at such field temperatures. If, as may be the case, the selected bed materials need a “warmer” ambient, then some system will need to achieve that temperature. Under these circumstances, the fuel temperature at the valves may set the achievable bed temperature.

Given a target bed temperature of 120°F, approximately 2,000 Btu/h of heat input would be required, of which about only 5% would be needed to warm the inlet fuel itself. The balance is heat loss by two sulfur removal cylinders, assuming a 1-in. insulation around the cylinders at a 30°F cabinet environment. Preliminary analysis indicates that the most workable and cost-effective arrangement would use a tube-to-cylinder contact from the thermal recovery system. However, this would necessitate moving the thermal recovery loop’s circulating pump, inlet screen, air separator, expansion tank, and TP relief valve inside the fuel cell power plant. Given that thermal recovery for water heating will likely be used at most, if not all, RFC sites, such equipment would be needed in any event, and it may be cheaper to have them installed at the factory (rather than paying a local site plumber \$65 an hour to install them elsewhere). Several cubic feet would, however, be added to the power plant’s volume, and this could be a cost issue. An alternative would be to put the odorant removal beds in a moderate temperature “oven” around the cell stack, particularly for solid oxide RFCs.

5.3.3 Site Odorant Measurement

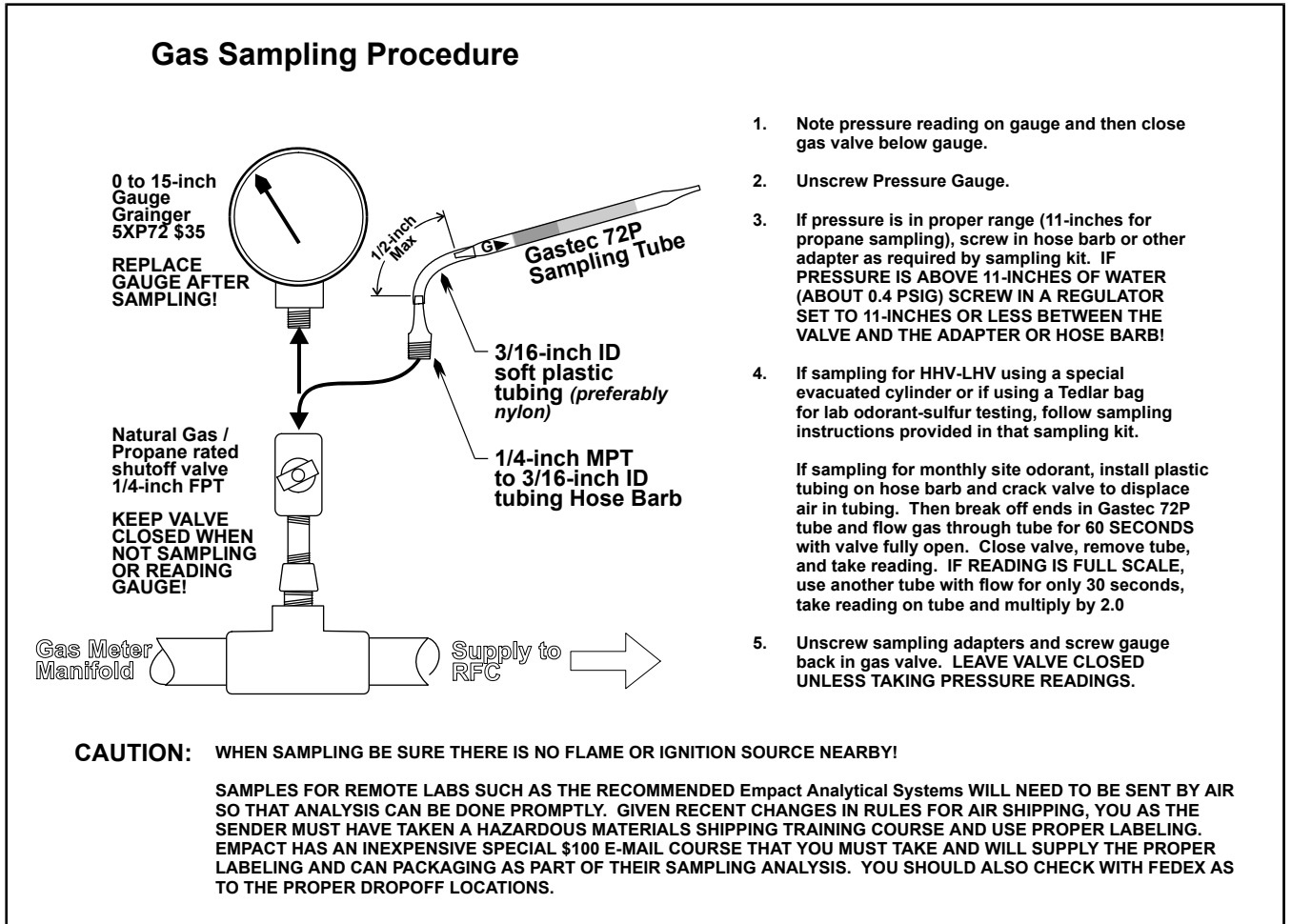

Figure 34. RFC odorant and heating value sampling protocol

A relatively simple procedure has been developed to sample ethyl mercaptan odorant in normal ranges. This uses a simple \$5 stain tube. With the Gastec 72P sampling tube, it takes just a minute to take a field sample with a normal range of 2.5–40 parts per million by volume for ethyl mercaptan in LPG/propane gas.

The sampling procedure shown in Figure 34 covers normal odorant levels. The sampling time can also be adjusted for odorant levels outside this range. At least one sulfur compound gas chromatographic test sample will be taken at commissioning as a cross-check and to determine if other sulfur-bearing compounds are significant enough to merit samples during demonstration.

6 Market and Grid Effects

6.1 Residential Customer Application

6.1.1 Load Prediction

Of interest in the assessment of grid DG potential and interaction with RFC residents is the profile of the larger customers to which RFCs are potentially more economically attractive. Valuable DG grid interconnect potential can be mined from DOE's Energy Information Administration. This agency conducts periodic energy surveys of residential energy use and markets. The 1993 survey collected data from more than 7,000 residential consumers across the country in the 10 census divisions.

These census areas are subsampled in city, suburban, town, and rural locations. Because anonymous data files are available for each interview, it is possible to use database software to construct a detailed picture of dwelling characteristics by geographic region and within urban and rural environments. Moreover, the survey collects actual annual electric use when possible and includes a detailed appliance and space-conditioning survey. Thus, the survey data have been mined to reveal electric use for more than 1,700 single-family or one-family detached dwellings where data were available.

Special statistical techniques then analyze the dwelling data to develop correlations of average annual use. The methodology, multiple regression analysis, analyzes the differences among the 1,732 lines of data to develop correlations among average annual electric use and other energy survey components. This analysis also incorporates survey parameters such as the dwelling square footage and local heating-cooling degree days.

The results are shown in Figure 35 and project, for example, that heating and cooling loads should be a function of degree days below 65°F and above 75°F, respectively. The analysis setup also uses the square root of the dwelling area because that approximates the perimeter wall length, where most heat losses and gains occur. The statistical analysis then starts through other uses and calculates the set of individual variables that best predicts the dwelling's total electric load.

The calculated predictors are overlaid on Figure 35. These indicate, for example, that the non-appliance heating-cooling base load is 0.41 kW plus 0.00019 times the heated area in square feet. The graph shows actual average annual load in kilowatts on the vertical axis and the projected kilowatt loads on the horizontal axis. Thus, a perfect prediction would produce a data point on the black 45° line. The analysis statistically predicts 49% of the variations in annual loads. Nonetheless, the data do provide a valuable starting point for considering the types of annual loads that would be associated with various types of dwellings and electric uses for RFC applications.

Actual versus Estimated Average Load as a Function of Residence Floor Area, Electric Appliance Saturation, and Electric Heating-Cooling Type . . .

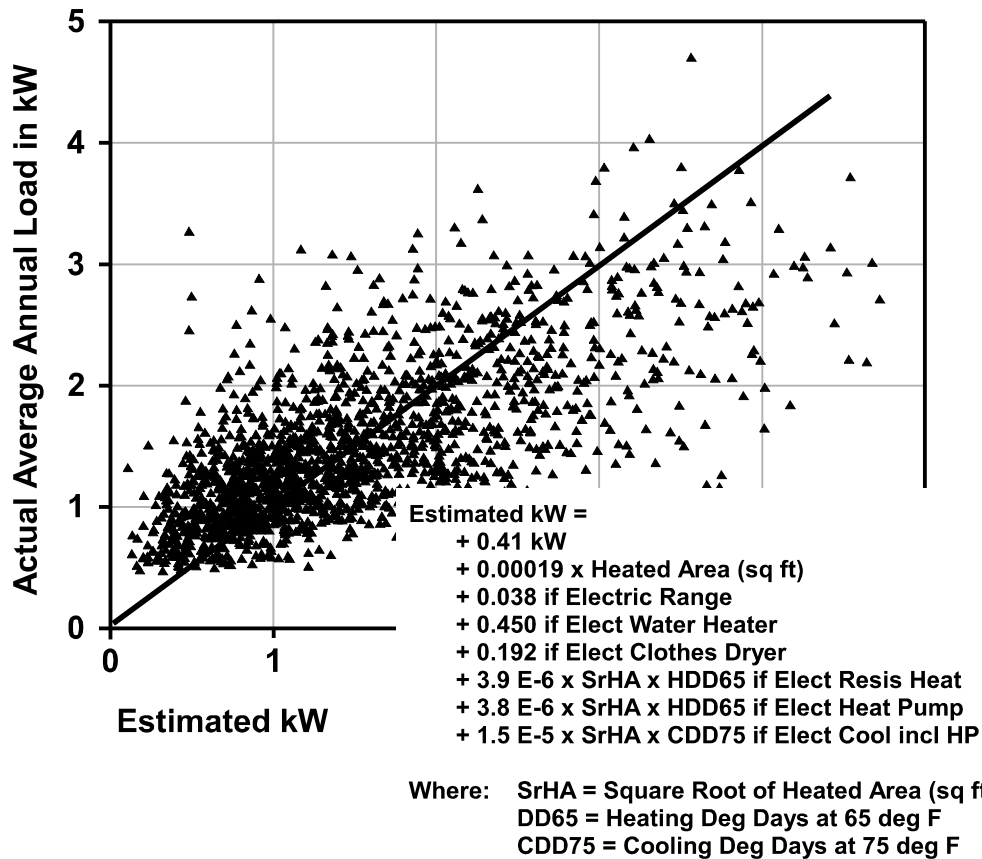

Source: *EnSig proprietary analysis of 1732 actual customer's measured use from raw 1993 EIA Census Data. Resulting r² is 49 percent accuracy.*

Figure 35. Residential annual electric energy use patterns

6.1.2 Customer Size and Application Profile

Even more important is understanding how the spectrum of customer-related uses interrelates with planned fuel cell capacities. Excluding electric resistance heating because those loads are inconsistent with RFC capacities, the results from 1,480 dwellings where detailed consumptions were available from actual utility bills have been analyzed. The frequency distribution curves are shown in Figure 36.

The data are only for single-family or one-family detached dwellings. The information has been processed to show the number and size of users relative to average annual electric loads in kilowatts. In effect, the data are calculated by dividing a customer's total annual kilowatt-hour use by 8,760 hours per year.

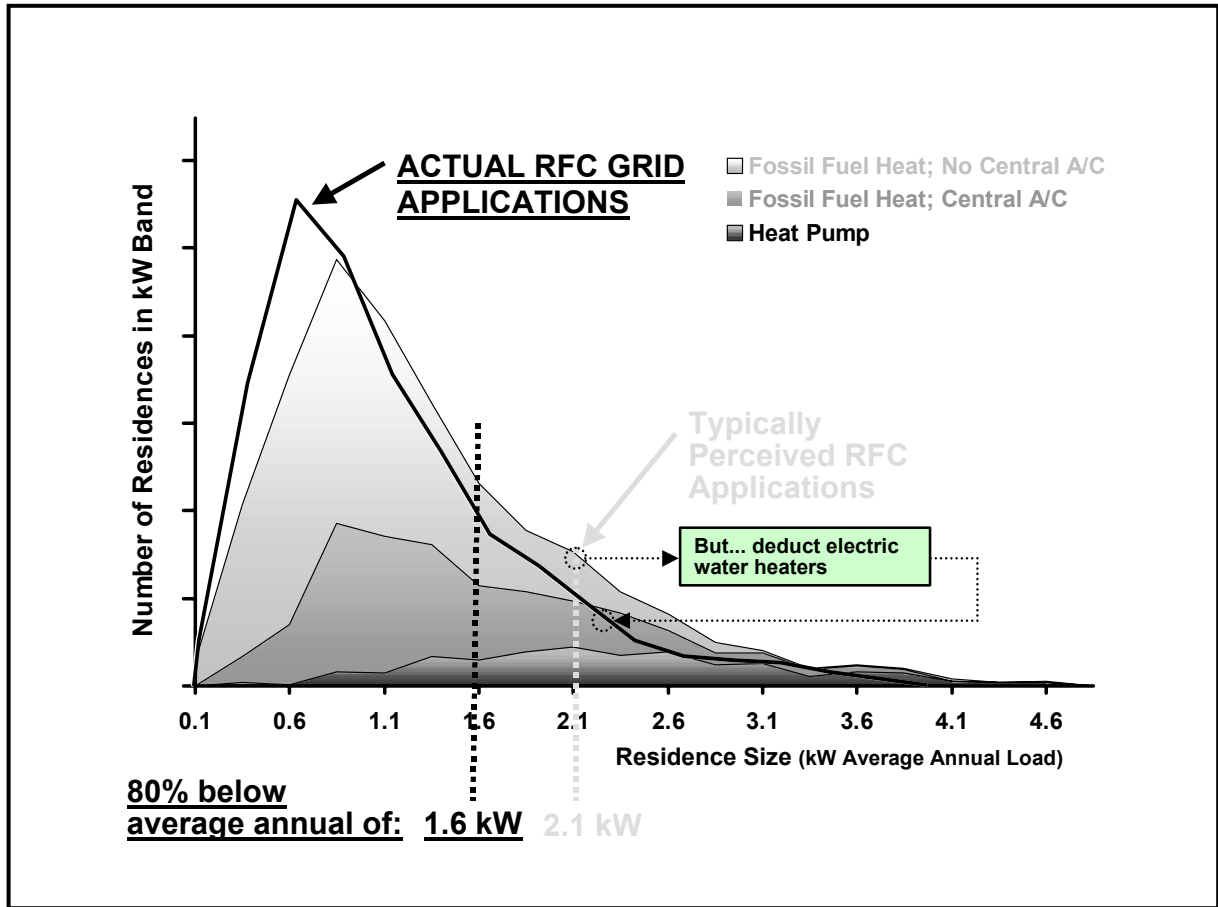

Figure 36. Residential fuel cell customer size profiles

The vertical axis denotes the number of customers in annual 0.25-kW electric use bands. The horizontal axis shows the customer’s average annual use in kilowatts. For example, a 1.6-kW customer would use 14,016 kWh per year (1.6 kW average x 8,760 hours per year) or 1,168 kWh per month. To provide a better appreciation of the key market classes of customers of RFC DG, the composite analysis is broken into three components. These are, from top to bottom:

- Residences that use natural gas or propane or oil heating and do not have central air conditioning
- Residences that use fossil fuel heat and do have central air conditioning
- Residences that use heat pumps.

Electric resistance heating has not been included because it has an atypically high electric use that is inconsistent with RFC applications. It would not make energy sense to convert natural gas or propane into electricity at 30% efficiency to use the resulting power in a baseboard electric resistance heater. A conventional gas or propane furnace would have 80% efficiency.

The heat pump dwellings tend to have a higher electric use than other classes of customers but represent a smaller portion of fuel cell applications. Although certain areas, such as the South Atlantic Census Division, have a heat pump saturation of more than 30%, the national average saturation of heat pumps is less than 10%.

Of particular interest, however, is the fact that the overall market distribution shows relatively small annual loads. The composite frequency distribution peaks at less than 1 kW. Moreover, 80% of the fuel cell applications have an average electric use less than 2.1 kW. In fact, many of these residences have electric water heating, considered a prime candidate for fuel cell thermal recovery. For example, 30% of urban and suburban residences have electric water heaters, and electric water heater saturations reach 67% in rural areas. Thus, the actual fuel cell customer electric use profile will be smaller because the electric water heater portions of the load would be converted to fuel cell thermal recovery.

Because the original data incorporate individual appliance surveys, it has been possible with to back out electric water heating loads and redevelop the market frequency distribution for RFC DG applications. This is shown by the solid black line in Figure 36. A full 80% of the fuel cell potential residences have an average electric use less than 1.6 kW. This suggests only a small fraction of the potential market will be able to take advantage of the improved fuel cell economics that occur with a larger average annual electric users. Larger electric loads spread the fuel cell's relatively high fixed cost over larger electric volumes and result in a lower average cost per kilowatt-hour to the customer. Uncovering these relationships is a crucial part of the CRN RFC demonstration program.

6.1.3 Customer Electric Demands

Given an understanding of average annual customer loads, the next most important factors in considering RFC applications are daytime versus nighttime loads. These affect the size of the RFC power plant relative to grid export power potential and the capacity needed for remote applications. Of course, remote fuel cell power plants also need to respond to instantaneous demands that can be much higher than hourly or 15-min peak demand profiles would indicate.

One source of information on composite load profiles is the CRN LoadShape program. In late 1997, this joint CRN/EPRI undertaking provided electric co-ops with important load profile data from EPRI's Center for Electric End-Use Data. The resulting output is a CD ROM-based library containing more than 1,000 annual load shapes for residential, commercial, and industrial customers. More than two dozen of these segments also include hourly weather-adjusted data for 20 city climates served by CRN members.

Table 9. Residential Peak Demand Electric Relationships

Typical Average Annual Load Versus Projected Day-Night Loads (kWh per Hour)

Average Annual Load (kW)	Assumed Night Load (10 p.m. to 8 a.m.)	Resulting Day Load (8 a.m. to 10 p.m.)
0.5	0.25	0.7
1.0	0.5	1.4
1.5	0.5	2.4
2.0	0.5	3.3
2.5	0.5	4.2

Typical Multipliers on Customer Average Annual Load to Get Hourly Demands

Type Desired	Multiply to Get "Likely Peak" By	Multiply to Get "80% Below Peak" By	
Typical fossil fuel-heated residence without electric water heater	Minimum Month	1.8	2.3
	Median Month	2.3	3.6
	Average Month	2.8	4.4
	Maximum Month	5.7	10.0
Heat pump residence without electric water heater	Minimum Month	1.6	2.7
	Median Month	2.4	5.0
	Average Month	2.9	5.8
	Maximum Month	5.0	9.7

Typical Appliance kW Demands and Related Average Annual Loads

	15-Minute Demand (kW)	Average Annual Use (kW)
Electric Water Heater	4.5	0.63
Electric Range	6.0	0.16
Electric Clothes Dryer	4.9	0.17
Central Air Conditioner	4.7	0.64

The basic LoadShape software is designed to estimate grid coincident hourly uses and demands relative to 10 or more users. However, the related LoadShape data also include coincidence factors, which are the ratio of the system peak to the average of the individual residence peaks. Typical coincidence factors are on the order of 0.25–0.37. Given this information, LoadShape information can be statistically deconstructed to gain an understanding of likely daily and peak residence loads.

Provided that heat pumps are not being used, most average and larger residences tend to show night hourly loads around 0.5 kW. The resulting day load can then be calculated in the first section of Table 9 because the average daily use is also known. For typical residences in the 1–2.5 kW annual use range, hourly day loads can be expected to be in the 1.5–3.5 kW range. This suggests that the optimum dispatch for an export-neutral fuel cell might be 0.5 kW at night and around 3 kW during the day.

Residential loads will vary with occupant use patterns and the number and types of appliances. The second section of the table shows multipliers on the average annual load to estimate likely peak hourly use. These resulting data are shown for minimum, median, average, and maximum months. For example, a customer with a 2-kW average annual electric use could be expected to have a likely maximum month hourly demand of 2 x 3.9 or 7.8 kW. Also shown are statistically calculated demands such that 80% of the associated values would be less than the calculated value.

An obvious question is: How can demands be so much greater than the average use, some of which are relatively low? The third section of the table shows the answer in terms of appliance demands versus related average annual use. For example, electric ranges and clothes dryers can have 15-min or longer demands on the order of as much as 4–6 kW even though their operating hours are so low that average annual uses are on the order of 0.15 kW.

6.2 End-of-the-Grid Applications

6.2.1 Co-Op Profiles

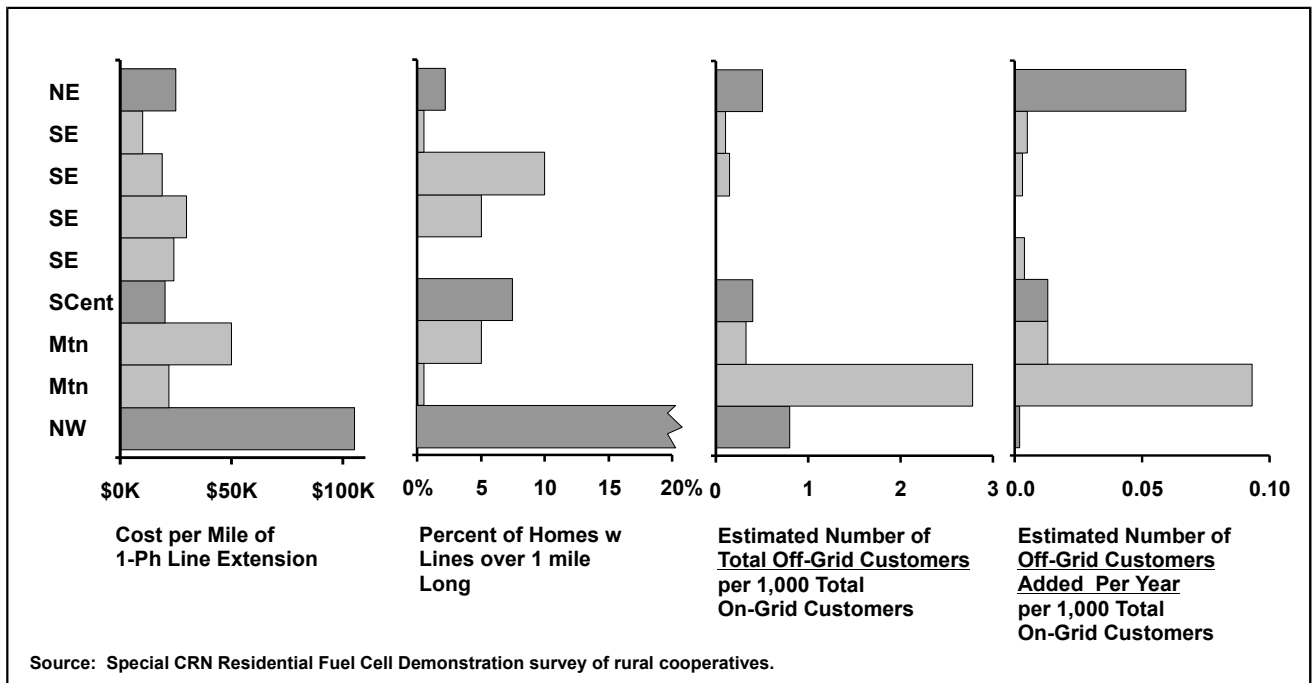

Figure 37. Rural co-op line profiles and remote market estimates

Rural electric cooperatives serve 15 million homes and businesses and represents 12% of the U.S. population. Even so, co-ops own almost 45% of the electric distribution line miles and cover 75% of the nation's land. The net result is that co-ops have 6.6 customers per distribution line mile compared with almost 35 customers for investor-owned electric companies.

As part of the CRN RFC demonstration program, co-op participants were surveyed to determine the potential for RFC DG as an alternative or supplement for serving particularly isolated sections of their service areas. Serving such customers is not inexpensive. Co-ops typically have 22 poles per mile, even for a single-phase distribution or customer service line. As Figure 37 illustrates, single-phase distribution lines typically cost at least \$10,000 per mile. In some regions of the country, they can cost \$35,000 per mile or more. The cost depends not only on the soil conditions for setting poles but also on right-of-way accessibility and clearing costs. Moreover, in some areas of the country, securing rights of way is extremely difficult because of federal regulations and customers who do not want poles "spoiling" their newly acquired view.

Co-op line extension policies have been tightened over the years and now generally allow only two or three poles without cost to the customer. New customers must pay the rest of the cost upfront as a contribution in aid of construction or finance it over a 5-year period at normal interest rates. As shown in the second graph of the figure, more than 5% of the homes on many co-op lines have service or distribution lines more than a mile long. Indeed, this percentage may be much larger for co-ops serving particularly remote regions. At \$10,000 a mile for a single-phase distribution service extension, a two-mile service line extension would cost the customer \$18,600. Conversely, this could be used to offset much, if not all, of the purchase and installation cost of even an early-market entrance RFC. This is one reason for co-op and customer interest in RFCs. Other factors include electric needs beyond the end of the grid, such as irrigation and communication facilities, and construction of residences beyond the economic reach of the grid.

The third graph in Figure 37 shows the estimated number of remote residences in the co-ops that responded to the survey. Actual remote residence data are difficult to come by because records are not required and no U.S. census questions explore this issue. Even so, co-ops typically have around 10,000 customers, and most in the Southeast report at least a few off-grid residences in their service territories. In the Mountain states, the estimate is 2 or 3 remote residences per 1,000 customers. Although not covered in this report, the survey also explored what systems these customers use to provide their power needs.

In terms of new customers, a few co-ops believe that remote residences are being added at a rate of about one per year per 10,000 existing customers, as shown in the right chart in the figure. One of the activities within the CRN RFC users group is to acquire and analyze remote residence data from all other sources, particularly the photovoltaic industry. These admittedly sketchy data indicate that the existing pool of remote residences represents about 0.4 homes per 1,000 existing residences, which is fairly close to co-op estimates for existing remote off-grid homes on their lines. Additional data from the solar industry report new annual remote residence construction around 0.1 per year per 1,000 existing on-grid residences. This is also consistent with co-op survey estimates.

The number of remote residence applications can be expected to vary geographically because of population and existing electric grid densities, the number of new people that find an area attractive, and the region’s general attractiveness for non-grid sources such as photovoltaics.

Moreover, a corollary issue merits significant, thoughtful future exploration. This is whether the existence of an attractive RFC option might encourage additional off-grid remote residence construction by individual owners or builders as fuel cell microgrids. For example, given the rise of cell phone and satellite technology, an attractive fuel cell option that replicates an on-grid electric lifestyle could open up the prospect of a number of attractive home sites in the South and West that have been so far bypassed by customers and builders because of the high extension costs or right-of-way permitting difficulties of conventional grid service extensions.

6.2.2 Comparative Cost of Off-Grid Technologies

6.2.2.1 Installation and Operating Cost Estimates

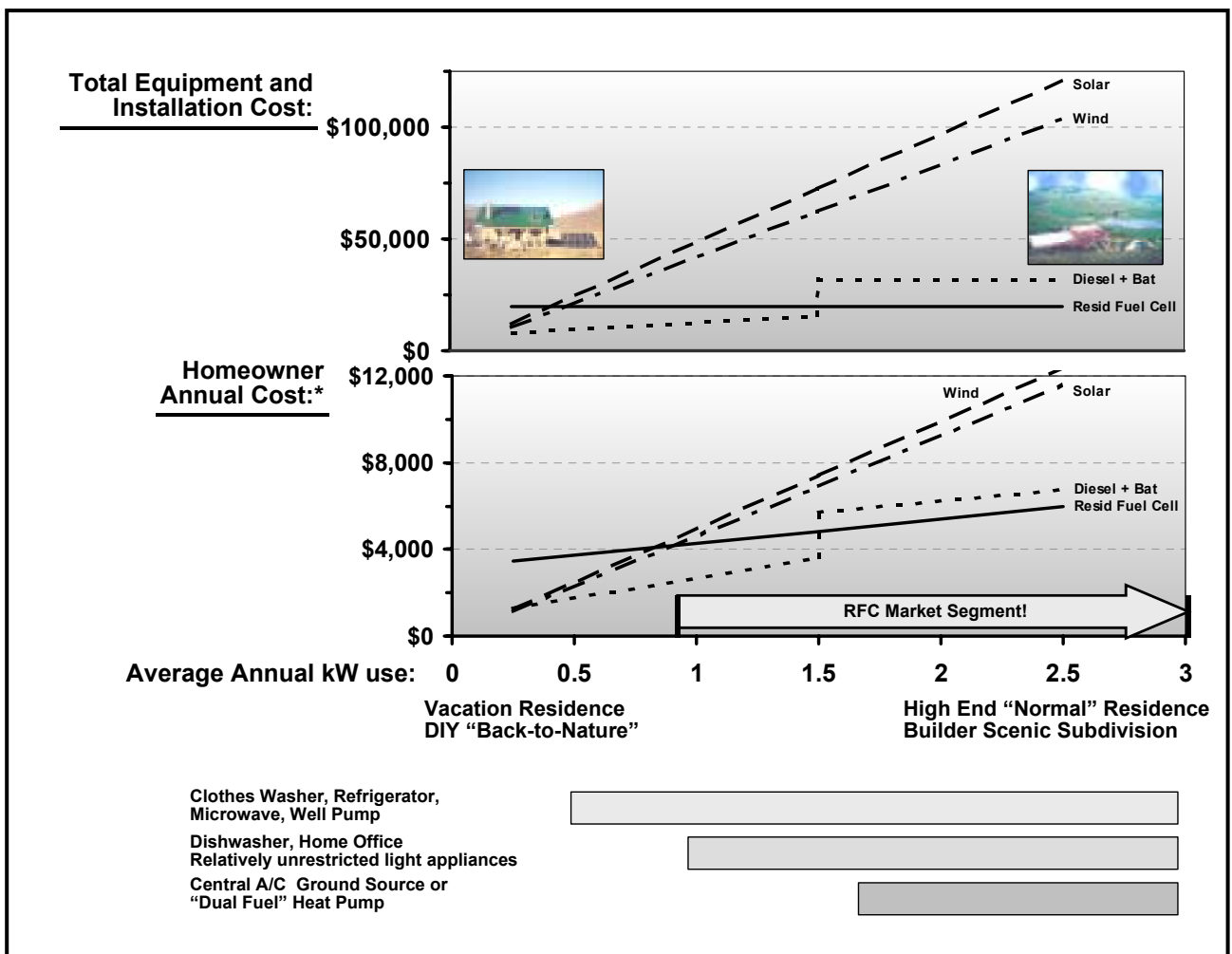

Figure 38. Comparative cost of off-grid technologies

With the exception of the noisy and service-demanding engine generator, the principal technologies for remote off-grid residential power applications are solar photovoltaic or wind generation. To understand how RFCs might fit into the picture, the CRN RFC demonstration program conducted an assessment of the costs, strengths, and weaknesses of remote residence options for review by the CRN RFC demonstration users group. Figure 38 summarizes these results for initial capital costs of equipment and installation and overall annual ownership and operation. The vertical axis shows cost, and the horizontal axis shows the dwelling load in terms of average annual kilowatt use. The horizontal bars on the bottom show customer loads typically associated with related annual use. Generally, unless the dwelling is a vacation, back-to-nature residence, annual average dwelling loads of at least 0.5 kW, and probably more like 1 kW, will need to be supported by the installation.

Unlike fuel cells, which range around 5 kW per power plant and can make more electric power by adding more fuel, solar and wind systems have a relatively fixed output. Thus, increased dwelling electric loads necessitate larger and larger capital investments. This is why cost lines for solar and wind power generation rise as dwelling power needs increase.

The solar and wind systems are assumed to be sited in regions generally favoring the technology. For solar, this meant the southern United States in an area that produced an average annual 0.19 kW of electric power for each 1 kW of solar panel capacity; for wind, it meant a “good” mid-continent location with a 20% annual availability. Thus, if anything, these assumptions are biased in favor of solar and wind systems.

The base system was assumed to target 1.5 kW of annual average power availability. This is on the high end of the capacity scale but takes full advantage of the economies of scale, if any, that exist for wind and solar technologies. Costs were assumed to be linear per kilowatt for solar and wind equipment and installation expenses, which probably tends to underestimate the cost of wind and solar at smaller installation sizes.

The solar system was most impressive. To produce 1.5 kW annually requires 60 140-W panels mounted on a roof area 54 ft long and 17 ft wide. Also included is a pair of 2.5-kW inverters and 10 kW of deep-discharge lead acid batteries. The equipment costs were \$55,400. Installation consumed 26 labor days, which might be low, and brought the total installed cost to \$67,900. To this is added a companion solar hot water system consisting of four 20-ft panels with an installed cost of \$4,900. The average annual cost of the system is based on a 25-year capital recovery period for the solar photovoltaic panels and components, including the inverters; the batteries are assumed to have a 6-year life. The cost of capital, or interest rate, is assumed to be 7%. The calculated annual cost of \$6,945 includes no annual maintenance allowance for any of the equipment. This \$6,945 annual cost is equivalent to \$0.499/kWh.

The wind system consists of a 7.5-kW generator with 12.5-ft blades mounted on a tilt-up 100-ft tower. The inverters and batteries are the same as those used for the solar installation and solar water heating system. Equipment costs for the wind-powered electric system were \$50,300, including a 500-ft pole-mounted wiring run from the residence to the wind tower. Installation consumed 15 labor days and brought the total installed cost to \$67,900. The wind system was assumed to have a 15-year life because of its mechanical components. The same interest rate and battery life used in the solar system were used. The resulting annual cost of \$7,435, which has no annual maintenance allowance for the equipment, is equivalent to \$0.525/kWh.

To complete the spectrum of alternatives, a long-life diesel engine system was also evaluated. The base system consists of two 6-kW China diesels, one of which is a spare, or a 12-kW Lister-Petter diesel generator. To this are added a prefabricated soundproofed shed; a 500-gal aboveground, double-wall oil storage tank; and a thermal recovery system. The same battery and inverter system used for the wind and solar systems is also included so the diesel system does not have to run continuously. The total installed cost is \$26,030, including 11 days of labor. The capital recovery costs are based on a 15-year life for the engines. The final annual cost is \$5,755, which includes 1,320 gal of diesel oil at \$1.15/gal and a \$130 yearly allowance for diesel maintenance. The overall annual cost of \$5,755 would be equivalent to \$0.411/kWh.

The RFC system consists of a 5-kW propane-fueled power plant that costs \$12,500. Also included in the system are a buried 1,000-gal propane storage tank and a full thermal recovery system. The installed cost of \$19,530 includes 6 days of labor. Based on a 10-year equipment life, the annual cost is \$4,810. Embedded in this annual cost are 1,630 gal of propane at \$1/gal and a \$400 annual allowance for service and maintenance. The resulting cost of \$4,810 per year is equivalent to \$0.366/kWh. Unlike solar panels and wind generators, the fuel cell and engine systems can provide increased annual residence power by burning more fuel.

6.2.2.2 Costs and Features Analysis

For solar and wind generation, panels or turbine capacity must be added to supply greater annual electric use. This capacity addition is an expensive capital cost and is why solar and wind power lines have a greater annual cost slope than diesel generators and fuel cell power plants, which can meet demand with the addition of more fuel. As the chart indicates, the fuel cell has lower installation than wind and solar systems that are sized for any thing larger than a do-it-yourself vacation or back-to-nature dwelling. Even with a fairly expensive propane fuel purchase, the RFC reduces “annual” costs at dwelling loads larger than 0.8 kW average annual use. Thus, the economic RFC market is generally above 4 kW of installed photovoltaic or wind capacity. Above this level, a fuel cell offers lower capital outlay.

The RFC also provides a relatively seamless “normal on-grid” living style because it can produce unlimited amounts of power provided that the hourly load is kept less than 5 kW. Although it uses a fossil fuel, the fuel cell is not affected by storms or adverse short-term weather conditions that can curtail power from solar and wind systems.

In addition, the RFC is more viewer-friendly. It has no visual pollution akin to roof solar panels or 100-ft wind turbine towers; there is no need to clear wind or sunlight shadowing trees. From an architectural point of view, the fuel cell does not require south-facing roofs and introduces no design constraints in dwelling siting or directional orientation. Thus, unlike solar and wind generation technologies, an RFC market entry would enable high-end builders to use existing designs and construction practices and their remote residence occupants to have close to an on-the-grid electrical lifestyle. Satellite and cell phone technologies have already cut the only other wires needed to a remote dwelling. For these reasons, the RFC is likely to expand the potential for remote residence siting more than solar and wind generation.

6.3 Overall Market Assessment

As explained in the demonstration overview, extensive market and sensitivity studies are under way as part of the CRN RFC user group effort. These results are based on extensive modeling of application issues integrated with analyses covering economies of scale and of production. The principal tool in this effort is the CRN RFC market analysis program in the CRN RFC tool kit.

Input data are from DOE's Energy Information Administration. The 1993 EIA survey collected data from more than 7,000 residential consumers across the country in the 10 census divisions. These census areas are actually subsampled in city, suburban, town, and rural locations. Because anonymous data files are available for each interview, it is possible to use database software to construct a picture of dwelling characteristics by geographic region and within urban and rural environments. This survey also collects actual annual electric use when possible and includes a detailed appliance and space-conditioning survey.

This spreadsheet program incorporates the 1,732 samples for which detailed consumptions were available from actual utility bills. Only single-family or one-family detached dwellings were used. Projected RFC power plant purchase and installation costs—including thermal recovery and propane tanks, where necessary—were then calculated for each dwelling. Options allow for the escalation of fuel prices and electric rates and for the use of regional electric pricing or fuel rates. The program then determines the cost of use of an RFC for homes not using electric resistance heat and whether each customer would have saved money on an annual basis.

This model has proved to be flexible because of its spreadsheet heritage and can incorporate a catalog of prospective fuel cell power plants so that the model's customers can "choose" the unit that best meets their load. This model has been principally used for sensitivity studies. Major results are highlighted in Figure 39.

- **Extremely sensitive to RFC power plant price**
\$5,000 covers none-to-full market band.
- **Five times as sensitive to electric prices as to fuel prices**
- **RFC economic markets differ among census regions because of fuel electric prices**
- **Only attractive heat pump customers are dual-fuel or ground source**
- **\$30 a month of perceived RFC benefits expands early economic market tenfold**
- **RFC catalog selection is crucial to “growing” market**

Figure 39. Key residential fuel cell market analysis results

A number of factors concerning critical application economics have emerged from the CRN RFC market analysis program software assessments. In addition to yielding fundamental insights into major application acceptance, these results have provided a sound, intuitive understanding of factors related to RFC market entrance application.

- The economic market (that is, whether the customer saves money) is extremely sensitive to RFC power plant price. Given a stable installation cost, a \$5,000 shift in fuel cell pricing covers the entire none-to-full market band.

Although this sounds unusually sensitive, this \$5,000 range would be equivalent to a shift of about \$710 in annual cost, assuming a 10-year equipment life and a 7% cost of capital or interest rate. When divided by the annual use of about 13,000 kWh for a typical 1.5-kW consumer, the result is a price swing of more than \$0.05/kWh. Such a change would cover much of the spread in residential electric prices across the country. This explains why the overall national economic market is so sensitive to fuel cell power plant price.

- Fuel cell markets are five times as sensitive to electric rate changes as they are to fuel prices.

Fuel cell economics use the differential between the electric energy price and the fuel price to pay for owning and operating the unit. Thus, the differential is more important than the absolute fuel cost. For example, assume that electric prices are \$0.07/kWh (or \$20.51/million Btu because there are 3,412.6 Btu in a kilowatt-hour) and that natural gas fuel prices are \$7/million Btu. At this point, the electric-to-fuel differential is \$20.51 minus \$7, or \$13.51 per million Btu. If electric prices were to rise 10%, the differential would increase by \$2.05. In contrast, if natural gas were to increase by the same 10%, the differential would only decrease by \$0.70. The economic market size, in effect the number of customers for whom a fuel cell would save money, is extremely sensitive to this electric-to-fuel energy cost differential, which further magnifies the inherent electric-to-gas price sensitivity.

- RFC economic markets differ significantly among census regions.

Consumer natural gas and propane prices, most likely because of transportation costs, vary significantly among geographic areas of the country. Electric prices also differ among census regions because of differences in the costs of and preferences for generation fuel. Moreover, the changes are not always symmetrical with fuel and electric prices changing the same relative amounts or even in the same direction. The result is that economic markets for fuel cells will emerge across the country with different regional timings because of differing regional energy price differentials.

- The only attractive heat pump installations will be dual-fuel or ground source units.

Normal air-to-air heat pumps move heat from outdoor ambient air to use for indoor heating. However, as ambient air temperatures become colder, the pumping differential between the indoor air and the colder outside air becomes larger, and the heat pump's ability to move heat diminishes. At the same time, the home's need for heat increases. At some temperature, such as 20°F, additional electric resistance heaters come on in the home's air blower to make up the difference between what the heat pump can deliver and what the dwelling needs. These electric heater loads can reach as much as 4–8 kW or more and are clearly too large for the fuel cell to run during a grid outage or at a remote residence. As a matter of fact, even running the compressor in a heat pump or similar central air conditioning unit is likely to be a stretch for the fuel cell. Dual-fuel heat pumps do not have electric heaters for low ambient temperatures and instead rely on a natural gas or propane furnace. The downturn in heat pump output at low ambient air temperatures is much less of a problem for ground source heat pumps because their buried coils rely on ground or well water temperatures, which are much warmer on cold winter days.

- \$30 a month of perceived benefits (such as protection from ice storm or hurricane outages and supplying home office or critical small loads) expands the early economic entrance market tenfold.

As alluded to earlier, the initial entrance markets will be greatly dependent on perceived benefits. Although \$30 a month may seem small to an outage-sensitive customer, it is equivalent of a \$0.027 electric price change, which is fairly significant when potential fuel cell economic savings are calculated.

- Proper RFC catalog selection is crucial to expanding the RFC market.

At this point, and probably well into its initial market acceptance, an RFC is likely to be a one-size-fits-all product. In addition, much of the annual cost of a fuel cell is tied up in its purchase price and installation cost rather than in the fuel cost to make the needed electricity. The result, if the catalog is not carefully selected, will be to price the unit out of economic reach for much of the low- and mid-size market because of high fuel cell fixed costs and low power uses to offset those costs. Even though economy of scale favors larger power plants, market acceptance and economies of production may favor increased sales of smaller, less expensive units over lesser sales of larger units. A critical piece that is missing in the RFC industry is a reasonable-quality residential DG application model and market foresight.

As illustrated above, the CRN RFC demonstration program and users group analysis has made headway in assessing and understanding key factors involved in implementing and growing RFC DG.

A related and equally important matter is understanding the RFC's prospective early-entrance market opportunities and issues. This is important because the early-entrance market represents a critical bridge between laboratory demonstration units and a mature DG RFC enterprise. Without successfully designing, building, and negotiating this bridge, no long-term RFC markets will exist.

Figure 40 shows some likely early entrance markets.

- **Off-grid homes and other off-grid uses**
 - Line extension for single-phase service line is \$10,000 to \$20,000+ per mile
 - Difficult or impossible to secure rights-of-way in parts of country
- **Home office users**
 - Avoid snow or ice storm interruptions (cost-effective digital satellite now available for telephone and Internet)
 - Avoid hurricane outages
- **Partial power supply to outage-sensitive office and other customers**
- **High-income technophiles or “greens”**
- **“Green” or upscale housing developers**

Figure 40. Residential fuel cell early-entrance markets

Remote residences are an important early market for RFCs, but little data exist to quantify the size of this target for existing homes or new construction. Also included in this category are other similar-size off-grid uses. New manufacturer offerings of propane-fueled demonstration power plants epitomize accelerated manufacturer interest in off-grid applications. The drivers for this market include the prospect of using avoided line extension costs to subsidize the high initial prices of RFCs. Moreover, even without this credit, early-entry RFCs should be able to produce substantial first-cost savings relative to like-capacity wind and photovoltaic systems. Although the details are not included here, the co-op surveys have identified other potential fuel cell markets for isolated power production (such as for communications equipment).

Separate early-entry markets exist for outage-sensitive grid users such as home office users and high-income residential users with similar concerns. Both are high-end users in regions subject to ice storm and hurricane grid failures, which can last for days or longer. Similarly sensitive users in the governmental and light commercial areas also appear to exist based on preliminary reviews. Examples include radio dispatch and communications facilities and backup power for convenience store lighting and gasoline pumps. In all likelihood, other similar applications remain to be assessed.

Other potential early-entrance markets exist with high-income technophiles or upscale customers desiring a “green,” low-emissions power source. However, relying on these to provide significant sales appears problematical without more information such as extensive surveys and focus groups. Focus groups have operated within the CRN DG program, but this is principally an effort requiring fuel cell manufacturer attention.

“Green” or upscale builders also represent a potential early-entrance market meriting consideration. These may represent subdivisions addressing customer concerns on electrical outage security or even microgrids in attractive but difficult-to-electrically-reach areas.

6.4 Need for Residential Distributed Generation Market Model

Valuable market application information has been mined from extensive analysis using the CRN RFC market analysis program. This software tool originally began as a means for co-ops to gain an intuitive, graphic understanding of their potential fuel cell economic market and how customer size, type of water heating, fuel prices, and electric rates affect that market. Input data are from DOE’s Energy Information Administration’s 1993 energy surveys of residential energy use and markets. The resulting spreadsheet program incorporates the 1,732 samples in the survey for which detailed consumptions were available from actual utility bills.

This CRN model has proved unusually flexible and can incorporate a catalog of prospective fuel cell power plants so that the model’s customers can “choose” whatever unit best meets their load. It has been subsequently used for the sensitivity study results reported in this and earlier sections. For example, Figure 8 strikingly illustrates the importance of manufacturer, industry, and research agency understanding of how economies of scale and production couple with market profiles in a complex development undertaking such as RFC DG.

The fact that these relatively groundbreaking analyses were conducted under the CRN RFC users group aegis illustrates:

- The value of having such range-finding analyses as the CRN RFC demonstration program within the DOE NREL program
- The pressing need for a “good,” industrywide market model to guide technology development and RFC application for DG planning.

This report’s market application results only scratch the surface of the value that could have been achieved, and should already exist, within the RFC development industry.

A “good” market model is fundamental to guiding the nation’s technology development goals and assessing if the related DG markets can or will exist. Figure 41 shows the fundamental characteristics that should be embedded in such a residential DG market model.

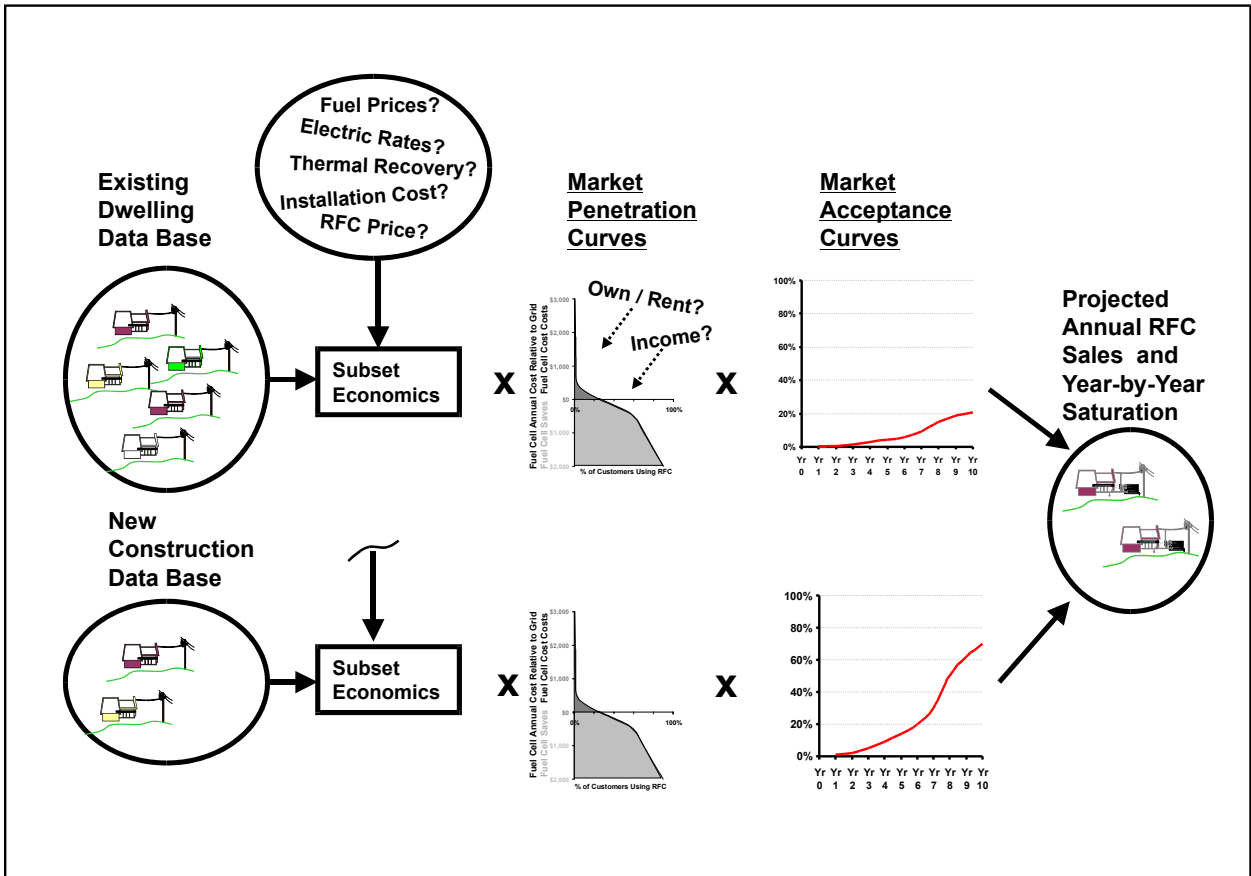

Figure 41. Residential distributed generation market model

To ensure universal applicability and acceptance, the market model protocol guidelines should be a joint effort of DOE and the DG industry. A special task force should guide the protocol effort with model development funding by DOE-NREL so that the end result is universally available. In addition to RFC technology and economic modules, strong consideration should be given to adding similar modules for solar photovoltaic, solar water heating, and wind.

As shown in Figure 41, the basic model would use input databases for new and existing single-family homes, including individual energy profiles with heating system and appliance types. Electric annual use should also be part of the profile. Although a number of private data sources are available, a merged database of recently conducted EIA surveys should be good enough. A statistical base of perhaps 3,000-5,000 should be sufficient, particularly if care is taken as to how census divisions are proxied. Included would be regional information on basic electric rates, fuel prices, and certain demographics.

The model would use the equipment module (RFCs, for example) to conduct residence-by-residence economic comparisons between the equipment and the dwelling's existing annual energy costs. Using annual savings or costs, a market penetration curve would then estimate the likelihood of purchase. A market acceptance curve subsequently predicts annual additions and cumulative DG capacity on regional and national bases.

The model should have the following type of structure and flexibility:

- A sufficiently large database of regional dwellings to provide statistically acceptable regional representations and accuracy. Included should be the individual dwellings' heating fuel; heating, ventilation, and air conditioning; and appliance types. Also included should be key demographics such as owned versus rented properties and income level.
- Costs should include regional or subregional electric rates, natural gas and propane prices, and escalation options for each energy type. Users should have the capability to override regional electric costs with a specific rate schedule and perhaps a dispatch module.
- Data subsets should cover new and existing housing as well as remote residences.
- RFC module calculations on a dwelling-by-dwelling basis that are capable of accommodating manufacturer price changes over time, installation costs by category, maintenance costs in cents per kilowatt-hour and total dollars per year, propane tank costs, optional dual-fuel additions for heat pumps, entry of a manufacturer catalog of sizes, related purchased costs, and part-load efficiency curves. Key variables such as total installation cost should be capable of overlaying a statistical probability distribution range of values for Monte Carlo simulations.
- Insightful market penetration overlay calculations, including separate adjustable market penetration curves for new and existing construction. These would essentially compute the percentage of persons who will use DG as a function of absolute annual costs or savings on a dwelling-by-dwelling basis. Included should be the flexibility for user-defined penetration models coupled with Monte Carlo statistical underlays. The latter would include driver calculations that are a function of key demographics such as owning versus renting and relative annual income level.
- Market acceptance buildup curves to accommodate how the percentage that use the technology will change as the product matures and consumer comfort levels increase.

This DG acceptance model would be invaluable to the manufacturing component of the industry, agencies involved in technology development guidance, and end-user utilities needing prudent DG planning. It could likely be developed in 3–6 months at a relatively nominal cost compared with the benefits of having such modeling capability for DG technology and application planning.

Full implementation of the model with solar and wind modules in addition to the RFC module would benefit all three of these DG technologies in development targeting, application analysis, and DG market penetration planning knowledge. To move this effort forward, the CRN RFC demonstration effort would work with other leaders, manufacturers, and model users in the industry on a limited-duration task force to set needed modeling protocols, serve as a test bed, and monitor the model's development and deployment. Development of this model would also complement needs already spelled out in DOE's "Grid 2030" Vision and Roadmap.

REPORT DOCUMENTATION PAGE

Form Approved
OMB No. 0704-0188

The public reporting burden for this collection of information is estimated to average 1 hour per response, including the time for reviewing instructions, searching existing data sources, gathering and maintaining the data needed, and completing and reviewing the collection of information. Send comments regarding this burden estimate or any other aspect of this collection of information, including suggestions for reducing the burden, to Department of Defense, Executive Services and Communications Directorate (0704-0188). Respondents should be aware that notwithstanding any other provision of law, no person shall be subject to any penalty for failing to comply with a collection of information if it does not display a currently valid OMB control number.

PLEASE DO NOT RETURN YOUR FORM TO THE ABOVE ORGANIZATION.

1. REPORT DATE (DD-MM-YYYY) May 2004		2. REPORT TYPE Subcontract		3. DATES COVERED (From - To)	
4. TITLE AND SUBTITLE Evaluation of the Field Performance of Residential Fuel Cells: Final Report			5a. CONTRACT NUMBER DE-AC36-99-GO10337		
			5b. GRANT NUMBER		
			5c. PROGRAM ELEMENT NUMBER		
6. AUTHOR(S) E. Torrero R. McClelland			5d. PROJECT NUMBER NREL/SR-560-36229		
			5e. TASK NUMBER DP04.1001		
			5f. WORK UNIT NUMBER		
7. PERFORMING ORGANIZATION NAME(S) AND ADDRESS(ES) Cooperative Research Network National Rural Electric Cooperative Association 4301 Wilson Blvd. SS9-204 Arlington, VA 22203				8. PERFORMING ORGANIZATION REPORT NUMBER AAD-1-30605-12	
9. SPONSORING/MONITORING AGENCY NAME(S) AND ADDRESS(ES) National Renewable Energy Laboratory 1617 Cole Blvd. Golden, CO 80401-3393				10. SPONSOR/MONITOR'S ACRONYM(S) NREL	
				11. SPONSORING/MONITORING AGENCY REPORT NUMBER NREL/SR-560-36229	
12. DISTRIBUTION AVAILABILITY STATEMENT National Technical Information Service U.S. Department of Commerce 5285 Port Royal Road Springfield, VA 22161					
13. SUPPLEMENTARY NOTES NREL Technical Monitor: Holly Thomas					
14. ABSTRACT (Maximum 200 Words) Distributed generation has attracted significant interest from rural electric cooperatives and their customers. Cooperatives have a particular nexus because of inherently low customer density, growth patterns at the end of long lines, and an influx of customers and high-tech industries seeking to diversify out of urban environments. Fuel cells are considered a particularly interesting DG candidate for these cooperatives because of their power quality, efficiency, and environmental benefits. The National Rural Electric Cooperative Association Cooperative Research Network residential fuel cell program demonstrated RFC power plants and assessed related technical and application issues. This final subcontract report is an assessment of the program's results. This 3-year program leveraged Department of Energy (DOE) and National Renewable Energy Laboratory (NREL) funding.					
15. SUBJECT TERMS National Rural Electric Cooperative Association; NRECA; Cooperative Research Network; fuel cells; thermal recovery; distributed generation; DG; distributed energy; Electric Distribution Transformation Program; National Renewably Energy Laboratory; NREL					
16. SECURITY CLASSIFICATION OF:			17. LIMITATION OF ABSTRACT UL	18. NUMBER OF PAGES	19a. NAME OF RESPONSIBLE PERSON
a. REPORT Unclassified	b. ABSTRACT Unclassified	c. THIS PAGE Unclassified			19b. TELEPHONE NUMBER (Include area code)