

Advanced Buildings PEM Fuel Cell System

Presented by
Kyle Taylor - Project Manager

IdaTech, LLC
May 26, 2005



This presentation does not contain any proprietary or confidential information

Project Number:
FC49

Overview

Timeline

- Project start date 9/15/03
- Project end date 12/31/06
- Percent complete 49%

Barriers

- See next slide

Budget

- Total project funding
 - DOE share \$6,266,590
 - Contractor share \$3,374,318
- Funding received in FY04
 - \$ 2,074,550
- Funding for FY05
 - \$ 900,000

Partners

- IdaTech, LLC
- Marriott
- Portland State University
- Puget Sound Energy
- Sempra Energy
- CSA



Barriers addressed

Distributed Generation Barriers

- E. Durability
- F. Heat Utilization
- G. Power Electronics

Fuel Flexible Fuel Processor Barriers

- J. Durability
- K. Emissions
- L. Hydrogen Purification
- M. Integration and Efficiency
- N. Cost

Component Barriers

- O. Stack Material and Manufacturing Costs
- P. Durability
- R. Thermal and Water Management

Objectives

- To demonstrate **high electrical and overall efficiency**, reduced energy consumption, and reduced emissions for hotel and follow-on applications.
- To **overcome technical and cost barriers** through the engineering, design and construction of an integrated system utilizing fuel processor, advanced fuel cell, and balance of plant subsystems.
- To **validate a 50 kW PEM fuel cell system** design through field testing at three separate facilities which have been co-selected by Marriott International, Portland State University, Sempra Utilities and Puget Sound Energy.
- To use the information provided from this demonstration to target early **market entry opportunities**.

Approach

- This project will achieve the program objectives by focusing on the following approach for the development of a high efficiency, low cost, high reliability 50kW PEM system:
 - Combination of Steam Methane Reformer (SMR) and Pressure Swing Adsorption (PSA) systems that are robust yet cost competitive.
 - Effective purification of natural gas and water sources that is long lasting and cost optimized.
 - Utilize industrial Balance Of Plant (BOP) components with established reliability records.
 - Membrane Electrode Assemblies (MEA) composition and operating conditions must be optimized for long life.
 - Part of the development effort for this project is to identify and verify a set of conditions offering minimal voltage decay and fuel cross-over.

Approach

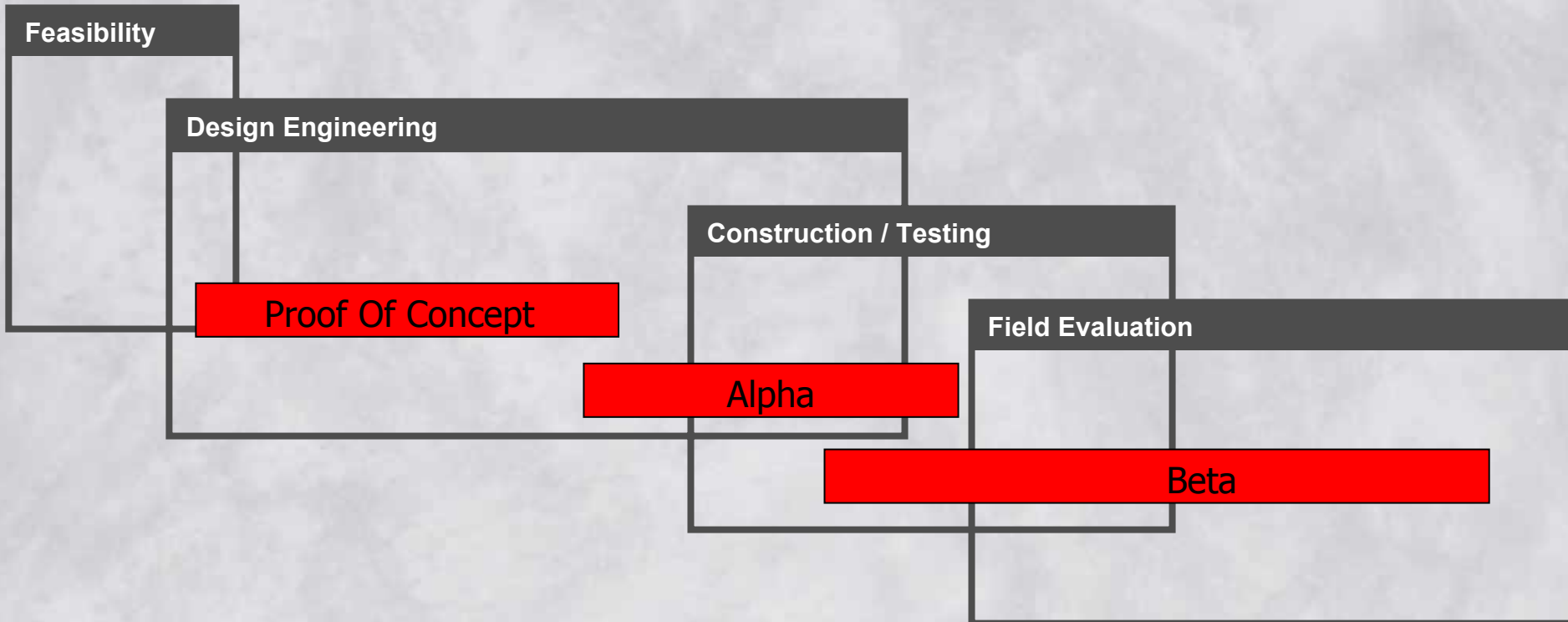

Approach (technical)

System Modularity by Function

Fuel Treatment Module

- Low maintenance interval, reliable sulfur adsorption
- Long life, high reliability water treatment
- High Recovery Pressure Swing Adsorption System

Fuel Processor Module

- Reactor design consistent with validated industrial designs
- Industrial Catalyst and Heat Exchanger Design
- ASME and CE Stamped Pressure Vessels

Fuel Cell Power Module

- Scale Up From Existing 5 kW Power Module
- Fuel Cell stack design optimized for long life
- Proven Industrial Power Electronics

Thermal Module

- Fuel Cell Temperature Control
- Condensing Heat Exchangers
- Low Pressure Drop

Technical Accomplishments

-Proof Of Concept Accomplishments-

- Operated 1/2 scale Proof Of Concept Fuel Processing system producing high purity hydrogen.
- Produced 400slm of high purity hydrogen
- PSA recovery consistent with program efficiency targets
- Validated Subsystems:
 - Water purification
 - Natural gas purification and compression
 - Pressure Swing Adsorption
 - Industrial Burner
 - Industrial Water pumps
 - Industrial Heat exchangers

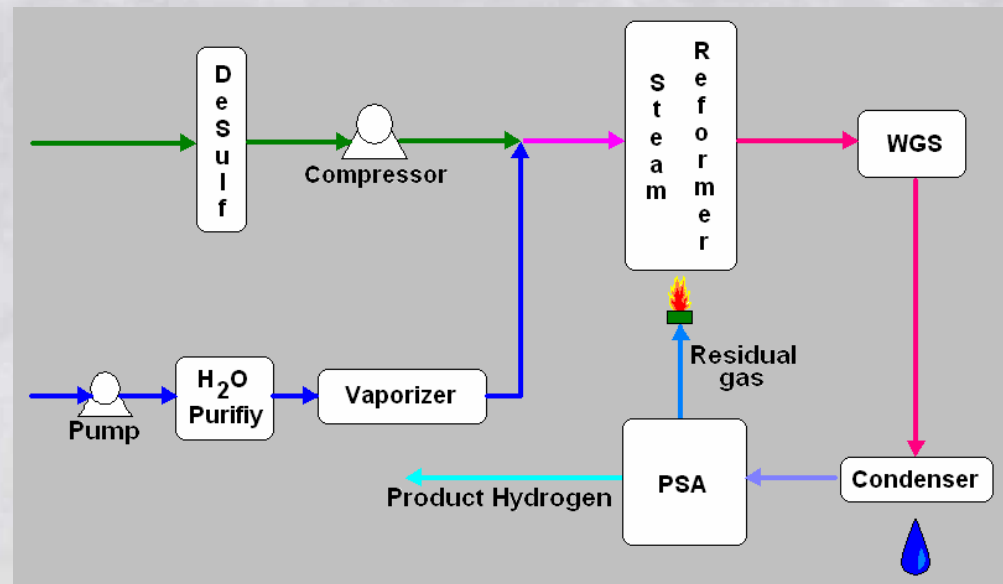

Proof of Concept System

Technical Accomplishments

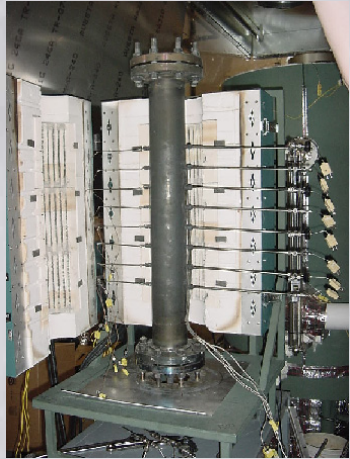

Sub-Scale furnace experiment

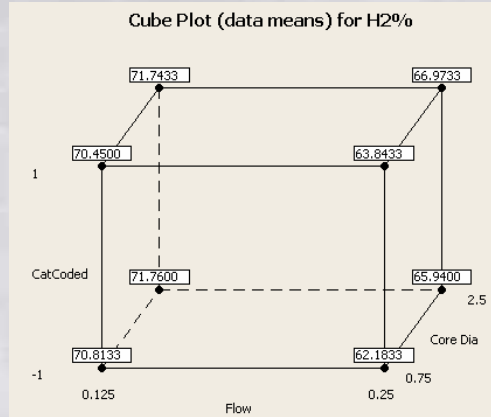

Design Of Experiment for Hydrogen output optimization

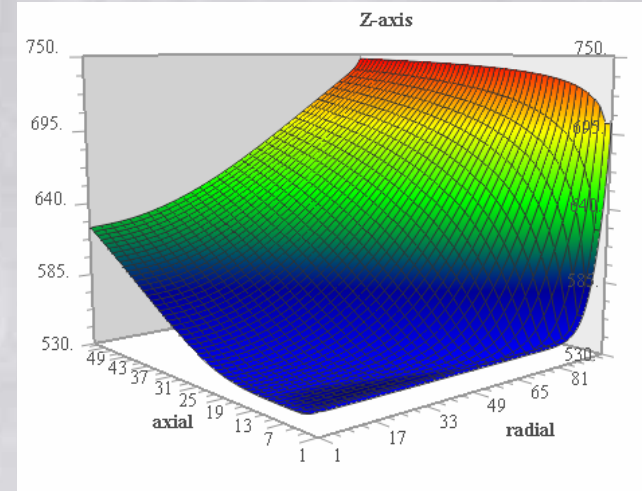

First principles Mathematical Modeling for Reactor design

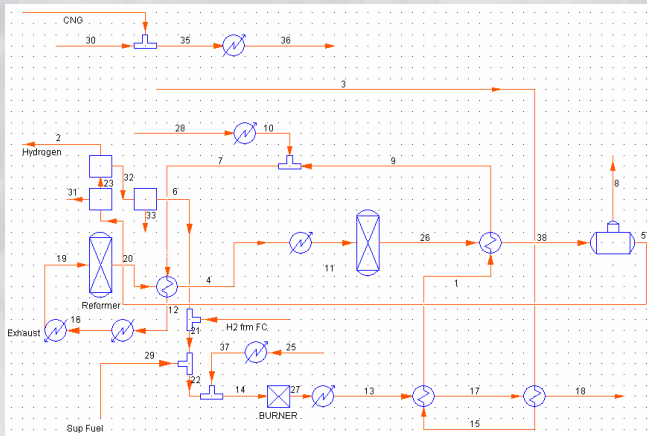

Process flow simulation for overall Heat-Balance

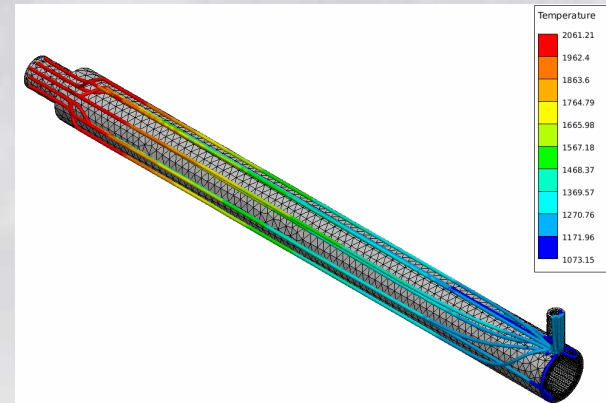

Computational Fluid Dynamics (CFD) for exhaust system temperature and flow optimization

Technical Accomplishments

-Fuel Cell Module/Power Electronics-

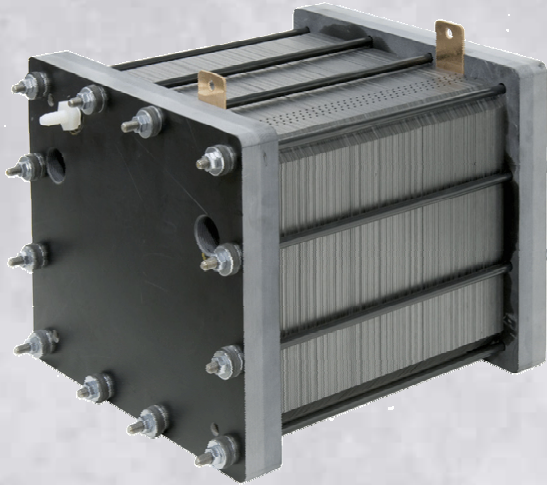

CM-50 STACK
PERFORMANCE

- Fuel Cell Module arranged and integrated for maximum performance

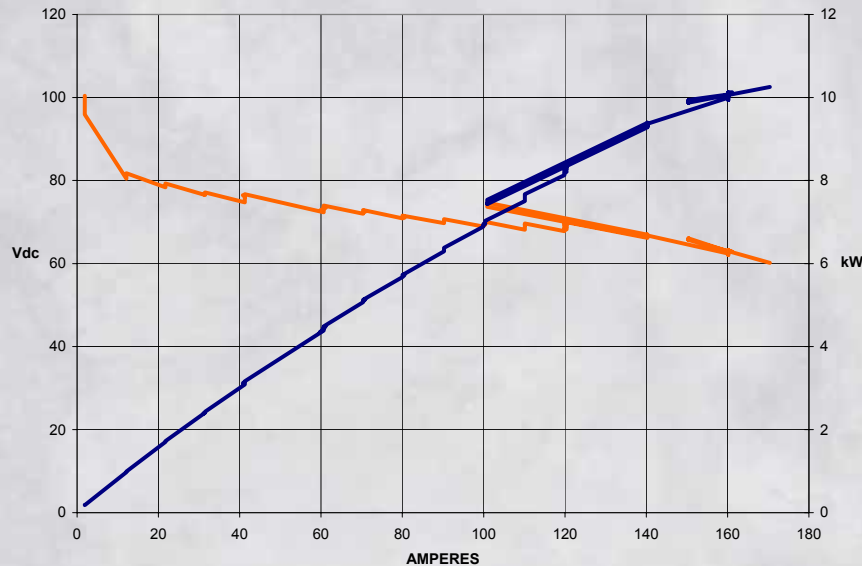

- Collaborated with power electronics supplier to optimize module for peak efficiency

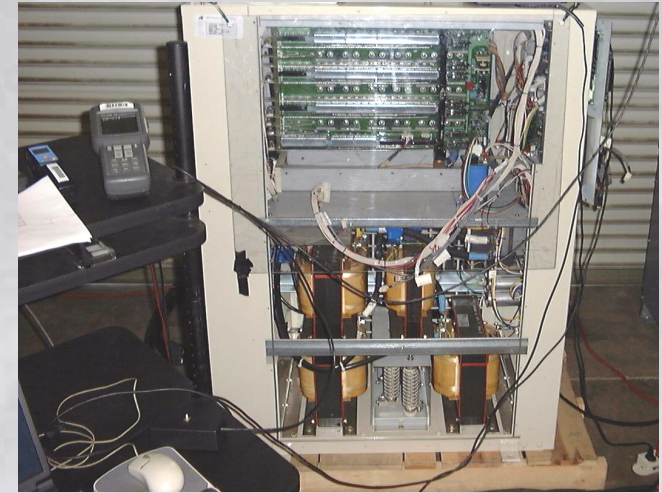

Technical Accomplishments

-Alpha System-

- Used past experiments and advanced modeling to develop the fully integrated Alpha system
- Layout was virtually designed to minimize tubing and electrical runs
- System modules are arranged for maximum serviceability
- System on schedule to be operational later this summer

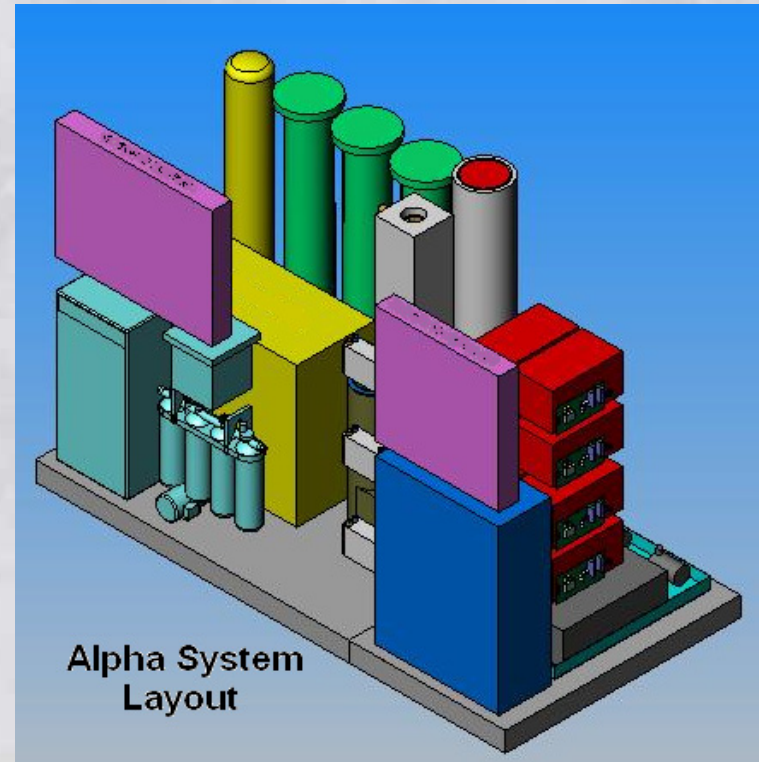

Future Work – Phase 2

Design Engineering: (Alpha)

Design verification of four system sub-modules: (FTM, FPM, FCPM, and TMM) using a proof of concept and Alpha development cycle. Alpha modules are integrated into a complete prototype system (Alpha-CM50) to be used for controls development and long term testing.

Task 2: Design Engineering	
Actions / Milestones	Deliverables
Proof of Concept Design	Special and Quarterly Reports
POC Test Data / Design Review	HAZOP Reports
Alpha Design	Code Compliance Review
Alpha Test Data/ Design Review	Alpha Demonstration

Completed

In progress

Future Work

Future Work - Phase 3

Construction and Testing: (Beta)

Document, cost improvements, and manufacture (Beta-CM50) power plants using six sigma statistical process control and ISO 9001:2000 methods

Task 3: Construction and Testing	
Actions / Milestones	Deliverables
Cost Improvements	Quarterly and Annual Reports
Design Documentation (complete Bill Of Materials and Assemblies)	Advisory Board Meeting
Factory Acceptance Tests	Final Design Package
Alpha endurance testing	Beta Field Deployment

Completed

In progress

Future Work

Publications and Presentations

- A. LaVen, "Advanced Buildings PEM Fuel Cell System," DOE Hydrogen, Fuel Cell, and Infrastructure Technologies Program Review Meeting, May 25, 2004, Philadelphia.

Hydrogen Safety

The most significant hydrogen hazard associated with this project is:

The production and utilization of a large volume of high purity hydrogen. This hydrogen is generated within the fuel processor section and is consumed within the fuel cell.

Hydrogen Safety

Our approach to deal with this hazard is:

To apply IdaTech's experience in hydrogen production, and handling to provide a safe operating environment. IdaTech is an ISO 9001 company, which has acquired UL and CE certification on equipment in the field, and has hundreds of man years of experience in safe hydrogen production and utilization.

IdaTech's test facility is equipped with hydrogen detectors which are connected to hydrogen sources to automatically shut off in case of hydrogen detection.

IdaTech is experienced with UL and CE standards that pertain to stationary fuel cell and reformer applications, and will continue to put into practice these standards. These standards include ANSI/CSA FC-1, ANSI/CSA FC-3, CSA 1.01 FC Supplemental, UL 2075, CGA G5.3, NFPA 70 article 692 , NFPA 853