

**2005 HYDROGEN, FUEL CELLS INFRASTRUCTURE
TECHNOLOGIES PROGRAM REVIEW**

**SMART FUEL CELL OPERATED RESIDENTIAL
MICRO-GRID COMMUNITY**

BY

DR. MOHAMMAD S. ALAM, Fellow – OSA, SPIE, & IEE

UNIVERSITY OF SOUTH ALABAMA

MAY 2005

**Project ID#
FCP18**

2005 HYDROGEN, FUEL CELLS INFRASTRUCTURE TECHNOLOGIES PROGRAM REVIEW

OBJECTIVES

- To expand the smart control algorithm to a micro-grid of ten houses
- To perform a system cost analysis
- To study system reliability
- To develop an energy management algorithm
- To perform micro-grid software and hardware simulations

2005 HYDROGEN, FUEL CELLS INFRASTRUCTURE TECHNOLOGIES PROGRAM REVIEW

BUDGET

- Phase I: \$2m
- Phase II: \$1m
- Phase III: \$0.5m

2005 HYDROGEN, FUEL CELLS INFRASTRUCTURE TECHNOLOGIES PROGRAM REVIEW

TECHNICAL BARRIERS AND TARGETS

Lack of Demonstrations or Examples of Real World Use:

- The 'Fuel Cell Operated Smart Home' gives educators and students the opportunity to gain hands-on and personal experience to improve their understanding and comfort when using fuel cell technology.
- Currently there are only a few real-world examples to which educators can point. The absence of installations and demonstrations also results in a lack of success stories and case studies to supplement educational materials and encourage early adopters.

2005 HYDROGEN, FUEL CELLS INFRASTRUCTURE TECHNOLOGIES PROGRAM REVIEW

APPROACH

- Number of homes determined
- Fuel cell power plant selected
- Layout designed
- Cost analysis performed
- Thermal recovery strategy devised
- Energy management algorithm developed

2005 HYDROGEN, FUEL CELLS INFRASTRUCTURE TECHNOLOGIES PROGRAM REVIEW

APPROACH (Contd.)

- Alternative energy evaluation
- System reliability
- Micro-grid simulation
- DAQ simulation
- PEM fuel cell simulations

2005 HYDROGEN, FUEL CELLS INFRASTRUCTURE TECHNOLOGIES PROGRAM REVIEW

SAFETY

- University of South Alabama Office of Research Compliance and Assurance inspects all laboratories annually
- Fuel Cell has extensive safety interlocks
- All electrical distribution panels have safety lockouts

2005 HYDROGEN, FUEL CELLS INFRASTRUCTURE TECHNOLOGIES PROGRAM REVIEW

PROJECT TIMELINE

- Phase I: Laboratory House and SEMaC completed
- Phase II: Micro-grid, LEMSYS and MEMSYS developed for micro-grid community
- Phase III: Energy management for micro-grid connected neighborhoods

2005 HYDROGEN, FUEL CELLS INFRASTRUCTURE TECHNOLOGIES PROGRAM REVIEW

TECHNICAL ACCOMPLISHMENTS/PROGRESS

- System cost analysis
- Alternative energy evaluation
- System reliability report
- Energy management algorithms
- Micro-grid simulation

2005 HYDROGEN, FUEL CELLS INFRASTRUCTURE TECHNOLOGIES PROGRAM REVIEW

INTERACTIONS AND COLLABORATIONS

- Teamed with Radiance Technologies, Inc. to develop SEMaC, MEMSYS and LEMSYS
- Made contact with other fuel cell research groups including CRN, Houston Area Research Center (HARC), and the Fuel Cell Testing Center (FCTC) in Johnstown, PA

2005 HYDROGEN, FUEL CELLS INFRASTRUCTURE TECHNOLOGIES PROGRAM REVIEW

PHASE III

- Smart energy management and control system for micro-grid connected neighborhoods
- Economic analysis
- Energy Management algorithms for load smoothing
- Hydrogen co-generation
- Smart energy management at the appliance level

Layout of Neighborhoods (Phase III Contd.)

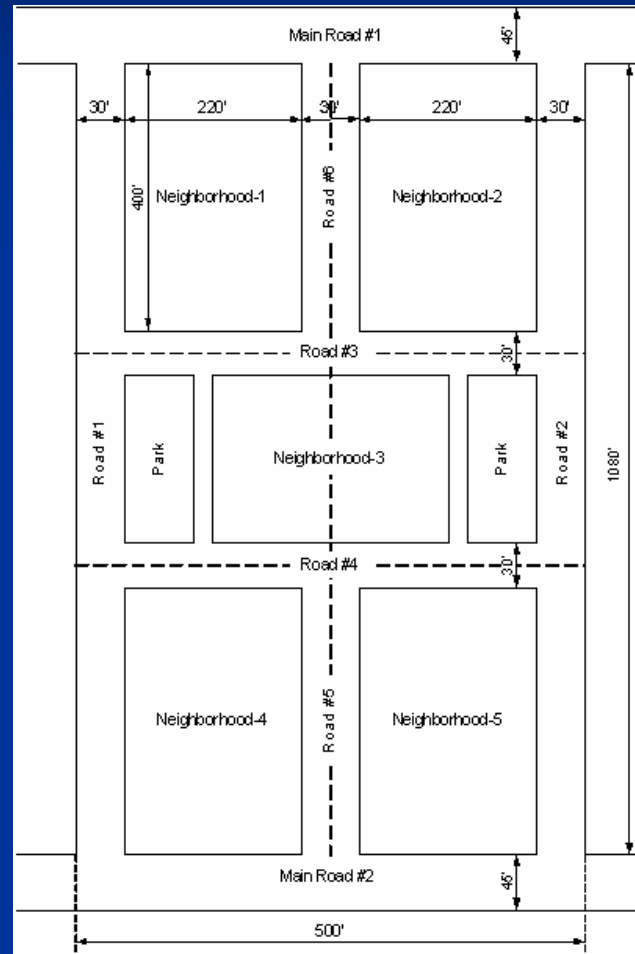

Mini – Grid Considerations

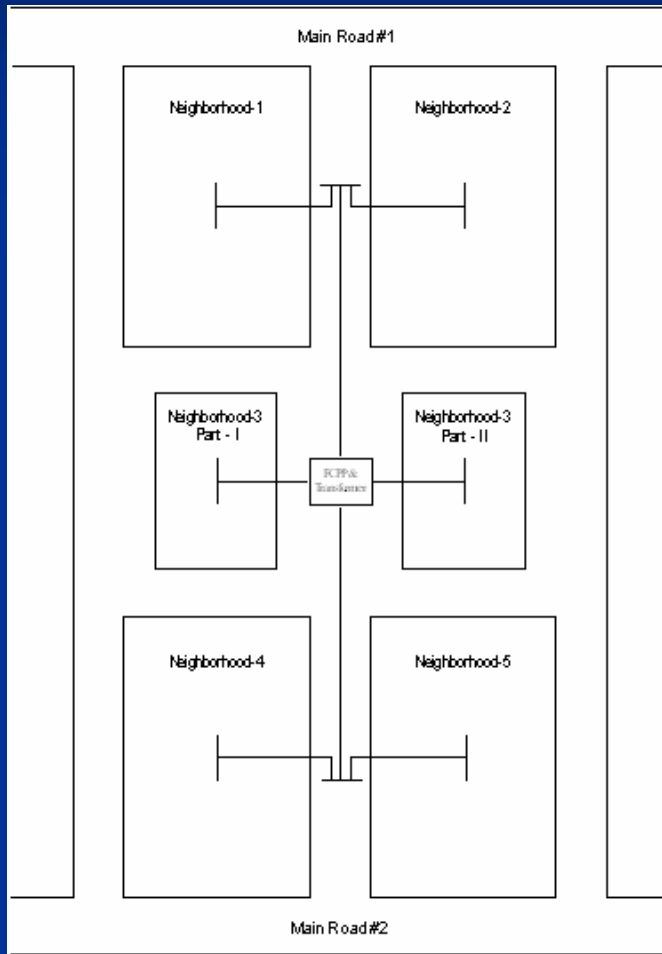

Single-Unit Design

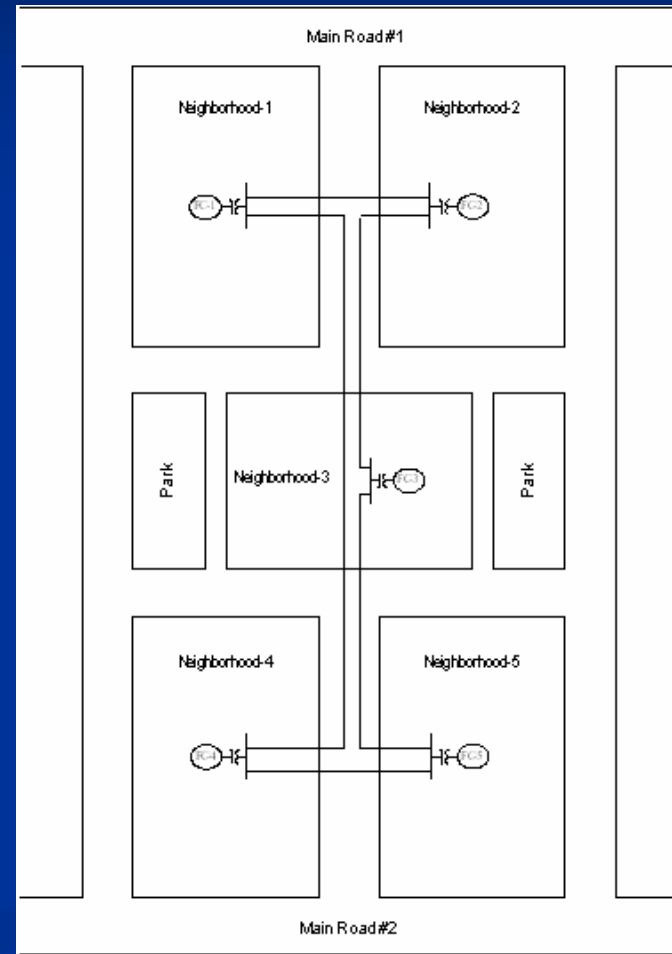

Multiple-Unit Design

Economics of Thermal Energy

Recovery : Objectives

- To determine a cost-effective use for thermal energy generated in the process of reforming natural gas to produce hydrogen
- To suggest a design for economical use of thermal energy
- To conduct a preliminary economic analysis

Approach

- A 50kW fuel cell produces approximately 30kW of thermal energy in conjunction with reformation of methane into hydrogen fuel
- The thermal energy is available for reclamation by use of a heat exchanger with ethylene glycol as the primary fluid and water as the secondary fluid
- The water enters the heat exchanger at a temperature of approximately 15C and exits at an outlet temperature of approximately 80C
- The temperature difference is too small for steam generation or for driving a stirling cycle heat engine
- The temperature is suitable for generation of hot water for domestic use
- Work during the first phase of the project concentrated on the details of central distribution of hot water to a micro grid community of 10 homes

Technical Accomplishments

- A system was designed to maintain central storage of hot water, which is continuously circulated in a distribution loop
- A secondary distribution system was designed to provide domestic hot water to individual residences
- A thermal analysis was done to determine the feasibility of the system
- An economic analysis was done to determine an approximate cost for the system

Assumptions

- 50kW fuel cell supplying 10 residences
- 30kW of thermal energy available
- Maximum hot water consumption of 250 gal/day/residence
- Peak consumption times of 7AM and 7PM
- Hot water supply temperature of 60C or greater

Micro grid Community

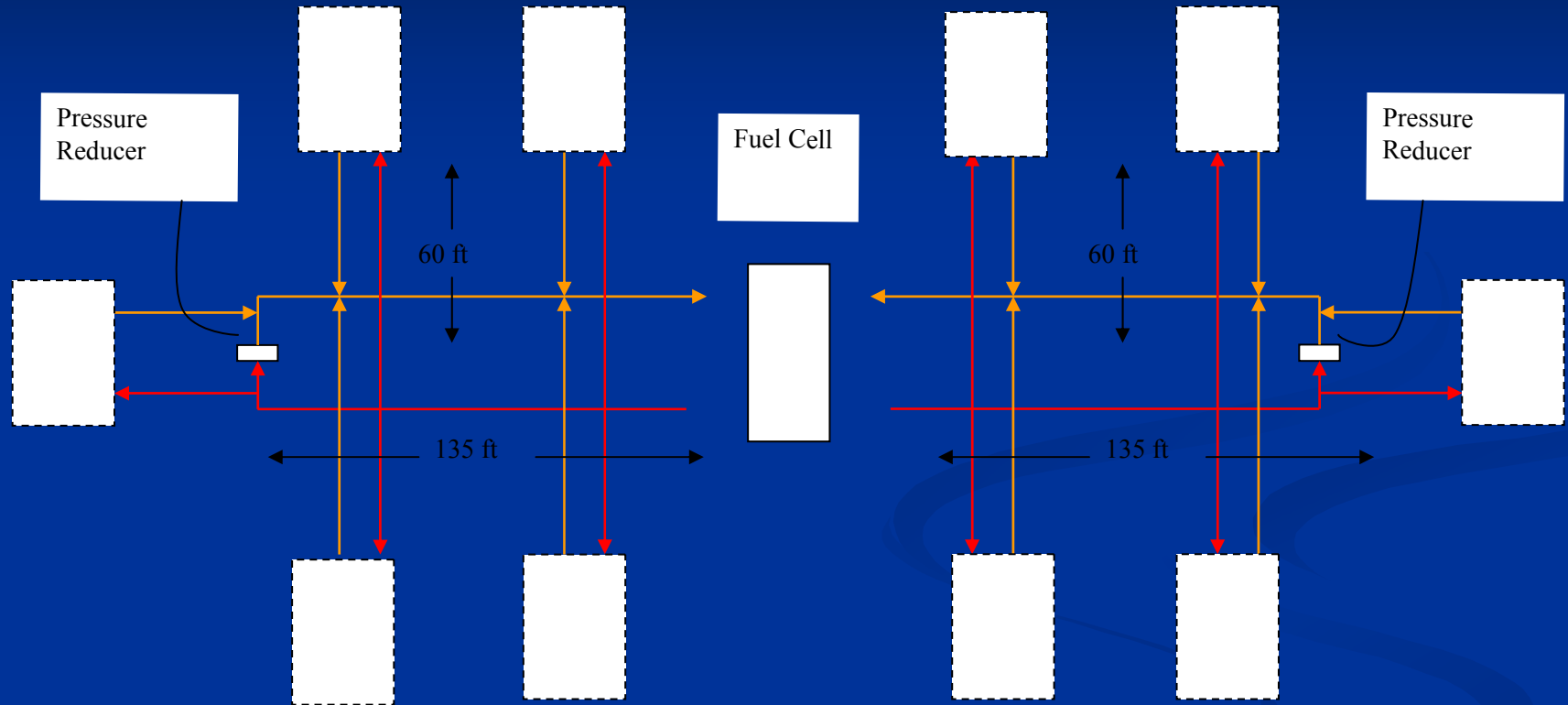

- Ten residences supplied by a 50kW fuel cell and reformer
- Hot water circulation through underground insulated pipes

Central Hot Water Distribution

- Water passes through the fuel cell heat exchanger and enters one of two storage tanks
- Hot water is circulated through underground piping to five residences from each storage tank

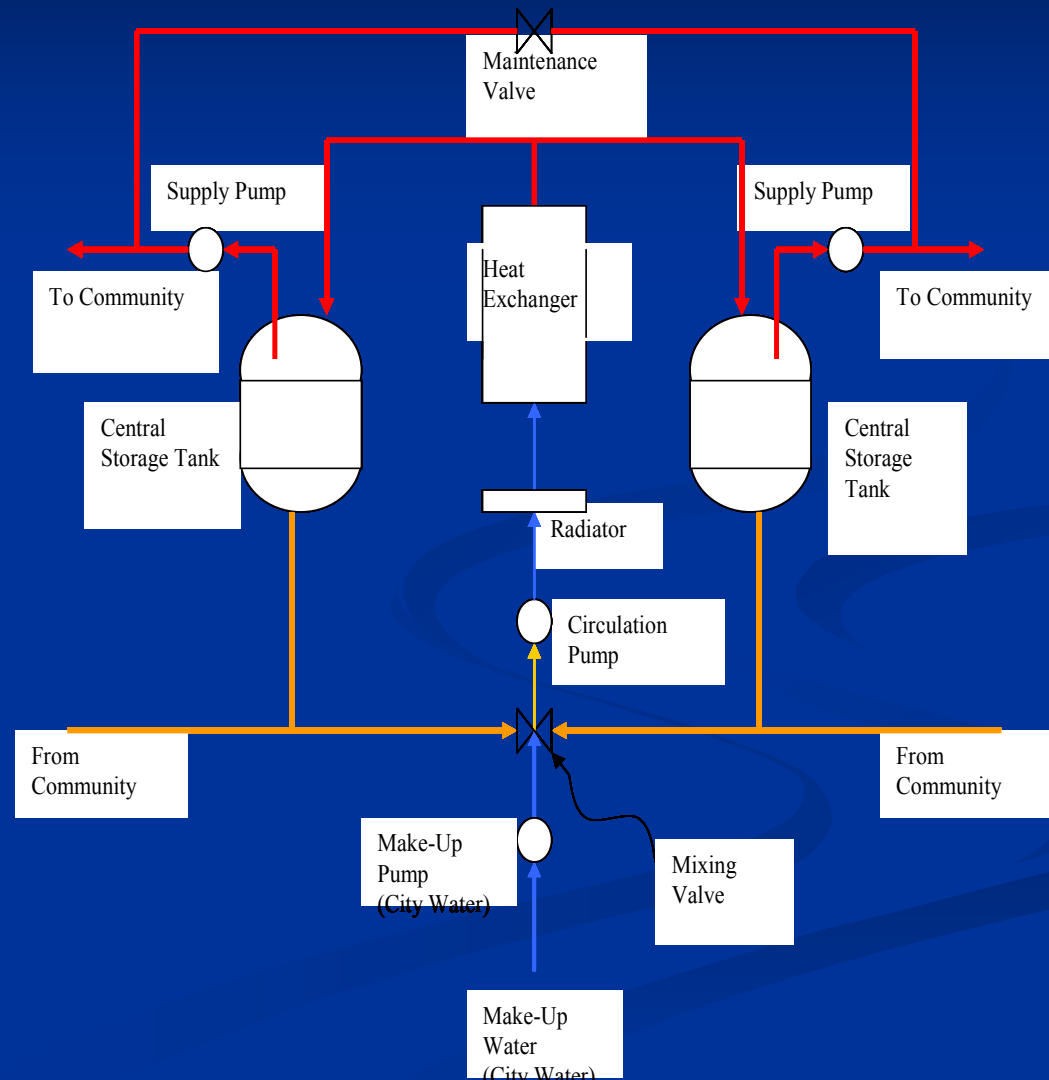

Residence Hot Water Distribution

- Hot water is supplied to a residential tank through a control valve
- The temperature of the water supplied to the residence is locally controlled
- A cold water mixing valve lowers water temperature
- An auxiliary heating element raises water temperature

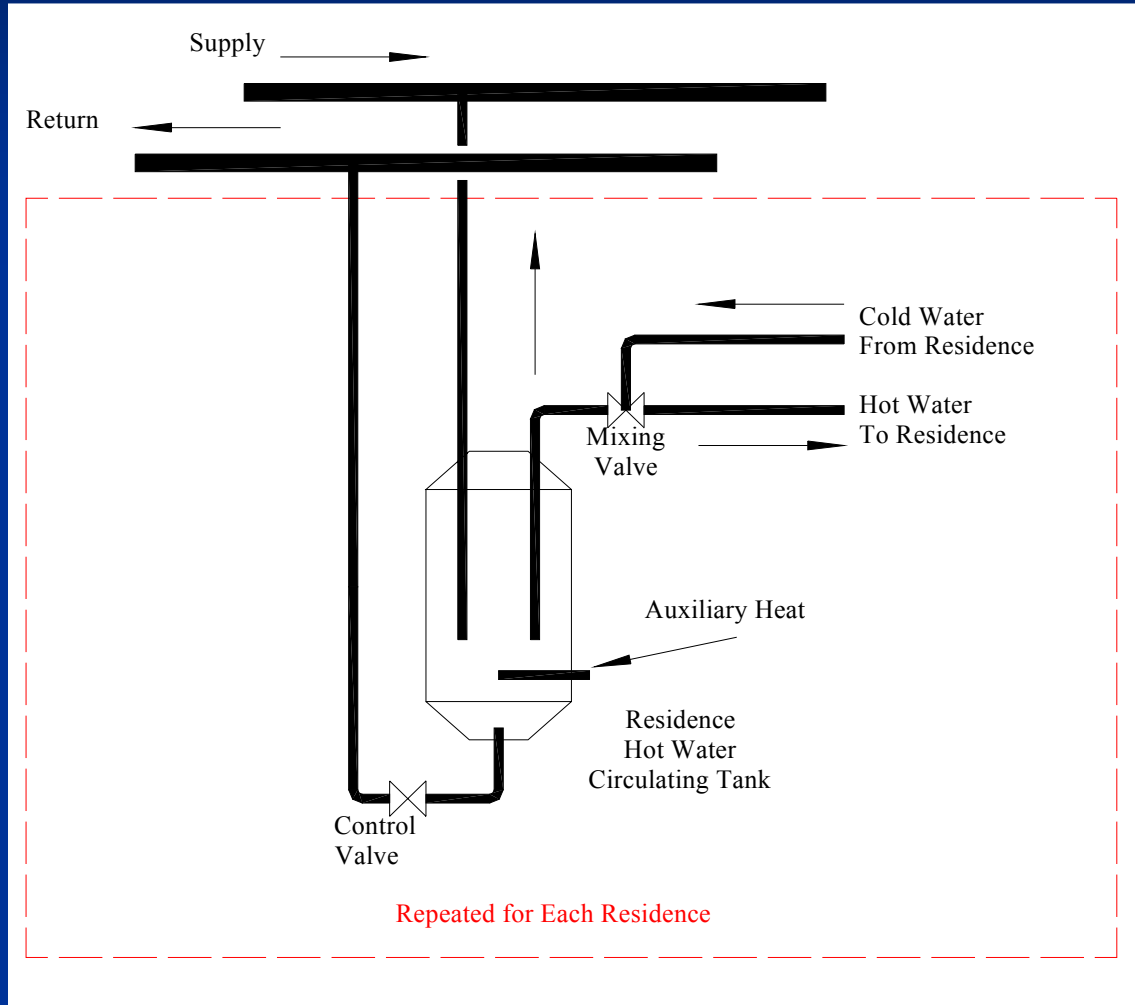

Estimated Component Costs

Component	Cost
550 Gallon Tank x 2	\$8,000
Pressure Pump x 2	\$2,000
Pump Controller x 2	\$5,000
Make-up Water Pump	\$400
Radiator Pump	\$400
Radiator	\$3,000
Piping (2 in. PVC)	\$1,000 (1.79/ft)
Pressure Reducer x 2	\$1,100
Valves	\$1000
Total System Cost	\$22,000

Table 1 - Components of the central distribution system

Component	Cost
40 Gallon Storage Tank w/ heater	\$150
Check Valve	\$100
Mixing Valve	\$100
Piping (3/4 in. PVC)	\$65 (1.79/ft)
Total System Cost	\$415

Table 2 – Components of the residential distribution system

Economic Analysis

- Central distribution system component cost: \$22,000.
- Residential system cost: \$415 per residence for a total of \$4150.
- Estimated installation costs: \$50,000
- Total system cost for 10 residence community: \$76,150.
- Cost per residence: \$7615

Future Work (Thermal Recovery)

- Extrapolate thermal recovery analysis to a 50-residence minigrid supplied by a 250kW fuel cell.
- Refine economic analysis
- Estimate maintenance costs
- Estimate operating costs and payback time

Reliability Modeling and Analysis of Grid-Connected PEM FCPP

- Fuel cell power plants are subject to a number of possible outage and derated states due to partial or full failure of auxiliaries.
- Furthermore, grid reliability indices such as failure rate, outage duration, etc. vary for different time period due to weather conditions, variety of power demands and random faults.
- Thus seasonal variation of grid reliability indices as well as partial or full failure of fuel cell auxiliaries should be considered for grid connected PEM FCPPs.

Reliability Modeling and Analysis of Grid-Connected PEM FCPP

- In the paper, a detailed state-space model of the grid-connected FCPP is presented which is a combination of proton exchange membrane fuel cell (PEMFC) Power Plant generation model and grid outage model.
- The state-space generation model of a PEMFC Power Plant is formed based on the failure modes of system auxiliary components. As for the grid outage state-space modeling, the effects of weather conditions such as normal and adverse weather are taken into consideration in modeling the failure and repair rates.

FC System Reliability Modeling

- A FC based power system mainly consists of a fuel-processing unit (reformer), FC stack and power conditioning unit.

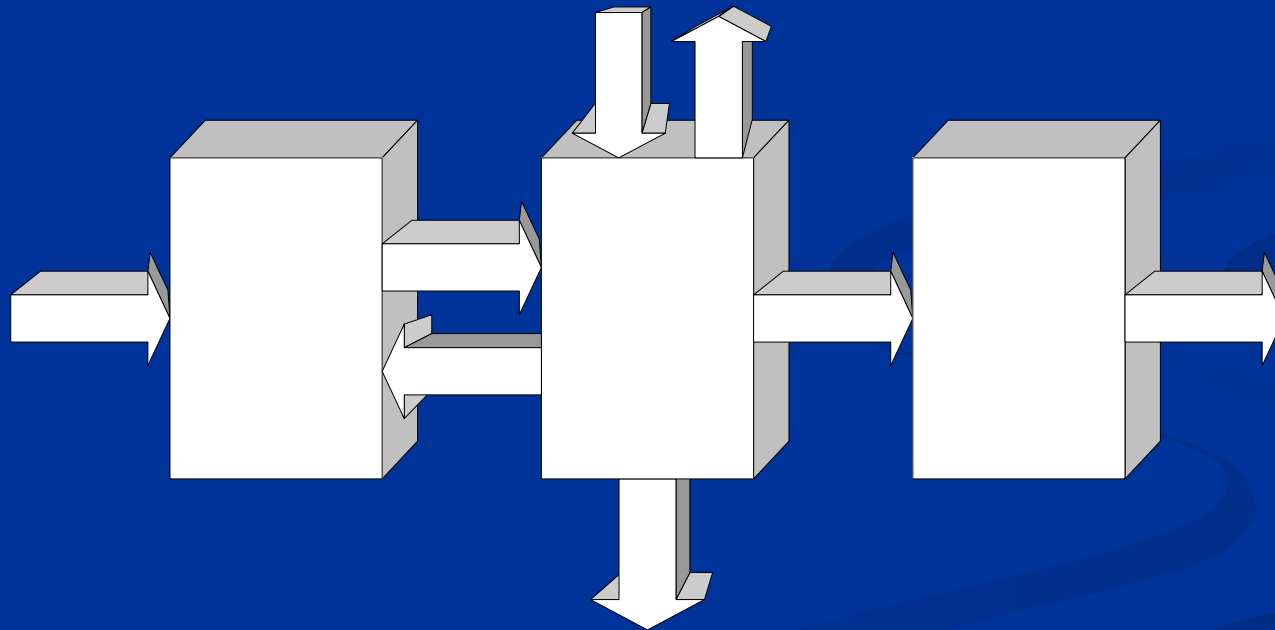

Basic fuel cell components

FC System Reliability Modeling

- The performance of a FC is generally characterized by using the polarization curve, which is a plot of the FC voltage versus load current.

$$V_{\text{stack}} = V_{\text{open}} - V_{\text{ohmic}} - V_{\text{activation}} - V_{\text{concentration}}$$

where,

$$V_{\text{open}} = N_0 \cdot (E^0 + E^1) = N_0 \cdot \left[-\frac{\Delta \bar{g}_f^0}{2F} + \frac{RT}{2F} \ln \left(\frac{p_{H_2} \cdot \sqrt{p_{O_2}}}{p_{H_2O}} \right) \right]$$

$$V_{\text{ohmic}} = (i + i_n) \cdot R_{FC} = I_{\text{dc}} \cdot R_{FC}$$

$$V_{\text{activation}} = N_0 \cdot \frac{RT}{2\alpha F} \cdot \ln \left(\frac{I_{\text{dc}}}{I_0} \right)$$

$$V_{\text{concentration}} = -c \cdot \ln \left(1 - \frac{I_{\text{dc}}}{I_{\text{Lim}}} \right)$$

FC System Reliability Modeling

- Although the basic concept of working of a fuel cell is quite simple, there are many auxiliary devices working behind the scene in order to operate the FC smoothly and efficiently.
- These devices that take part in the gas and electricity management are used in order for regulating the parameters such as reactant flow rate, total pressure, reactant partial pressure, temperature, and membrane humidity at a desired value.
- Hence, FC can run smoothly without getting the stack either flooded or drying out.
- Accordingly, any malfunctioning, performance loss and/or failure in these auxiliaries can lower the overall performance of the Fuel Cell.

FC System Reliability Modeling

- Various auxiliary components such as air compressors, pumps, humidification equipment, blower and coolers are used in the FC system that are all related to thermodynamics and flow control. Besides, the components such as power conditioning unit (DC/DC converter plus DC/AC inverter), control electronics, energy storage and transformer take part in power conversion and overall system control.

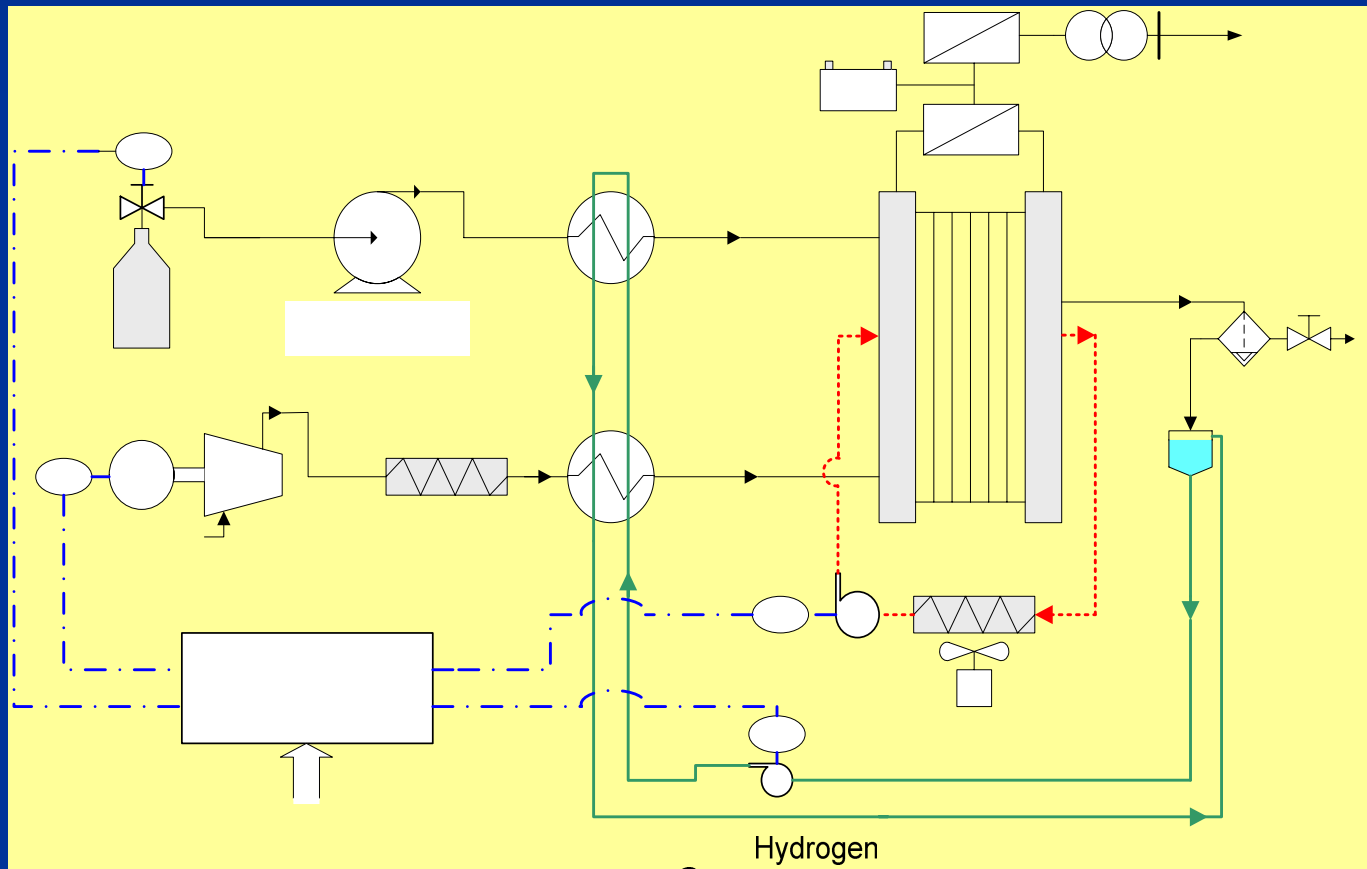

PEM fuel cell system block diagram that shows the auxiliary components along with input and output signals.

FC System Reliability Modeling

- In this project, a FC reliability assessment model has been developed, which is based on the possible results of auxiliary failures. The model calculates the effects of performance reduction in FC sub-systems on overall FC performances.
- The model can be summarized as below, where λ is failure rate and μ is repair rate.

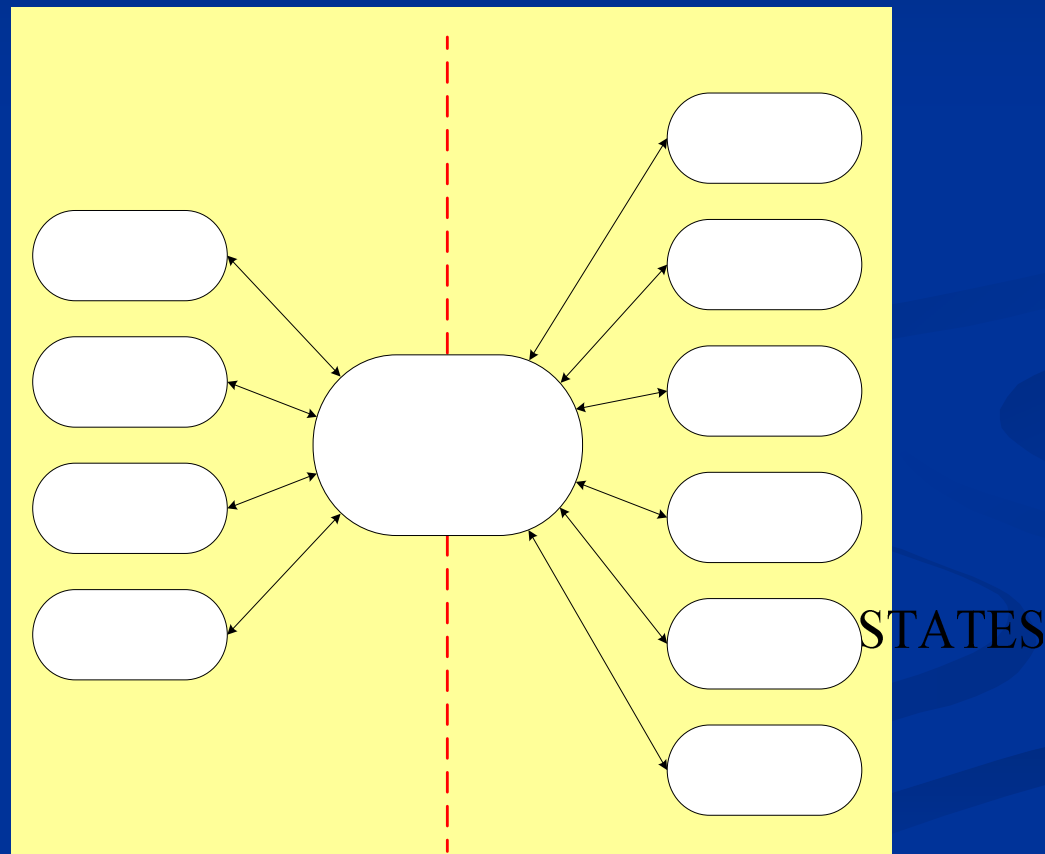

The state-space model of the FC generating unit.

FC System Reliability Modeling

- Table summarizes the effects of inadequacies/failures of FC sub-systems on the system output power with their state-space models.

FC Sub-Systems	Failure Severity	FC System	State-Space Representation	Possible Inadequacy Effects on System Output
Cooling System	Inadequacy Down	Derated Down		Output power will be derated by RP_C % due to increase in temperature and internal resistance
Humidification System	Inadequacy Down	Derated Derated		Output power will be derated by RP_H % due to increase in internal resistance and decrease in partial pressure of the reactants
Fueling System	Inadequacy Down	Derated Down		Output power will be derated by RP_a % due to decrease in hydrogen supply and/or degeneration of pure hydrogen
Air Supply System	Inadequacy Down	Down Down		Relative inadequacy of air supply will not lead reduction in output power, but may result in complete system failure if it is so severe.
Energy Storage System	Inadequacy Down	Derated Derated		Output power will be derated by RP_{ES} % due to FC stack and battery degradation.

- The state-space based reliability calculation is performed using Markov models. The system equation of Fig. 9 can be written in the form of state-space as

$$d\mathbf{P}(t)/dt = \mathbf{A} \cdot \mathbf{P}(t) \quad \text{where, } \mathbf{P}(t) \text{ is the probability vector of all states}$$

and, \mathbf{A} is the transition matrix.

Reliability Calculation

- Normally, Markov Model based system reliability is calculated by summing up all the operating state probabilities as shown below:

$$R = \sum_{i=1}^n P_i$$

- where P_i is a row vector and shows operating state probabilities. However, our concern is related to both up and derated states. If these state probabilities are grouped in the vector, then $P_i = [P_1^u \quad P_2^u \quad \cdots \quad P_m^u \mid P_{m+1}^d \quad P_{m+2}^d \quad \cdots \quad P_n^d]_{1 \times n}$

where “ u ” represent the up states and “ d ” represent the derated states.

- Thus the derated state probabilities must be reduced by a reduction factor appropriate to the deratings. To take this effect into calculation, consider a correction vector, C_i defined as $C_i = [1 \quad 1 \quad \cdots \quad 1 \mid c_1 \quad c_2 \quad \cdots \quad c_n]_{1 \times n}^T$

where, $c_i = 1 - RP_i^{\%}$ and $RP_i^{\%}$ is the percent power reduction corresponding to each derated state.

- Hence, the individual reliability of the system elements can be calculated as

$$R = [P_i]_{1 \times n} \cdot [C_i]_{n \times 1}$$

Reliability Calculation

- Afterward, individual FCPP and grid reliabilities are combined to obtain the whole system reliability using network representation technique. Since this project deals with grid connected PEM FCPP that supplies a typical residential house through a transformer, the reliability model of the system can be depicted as below:

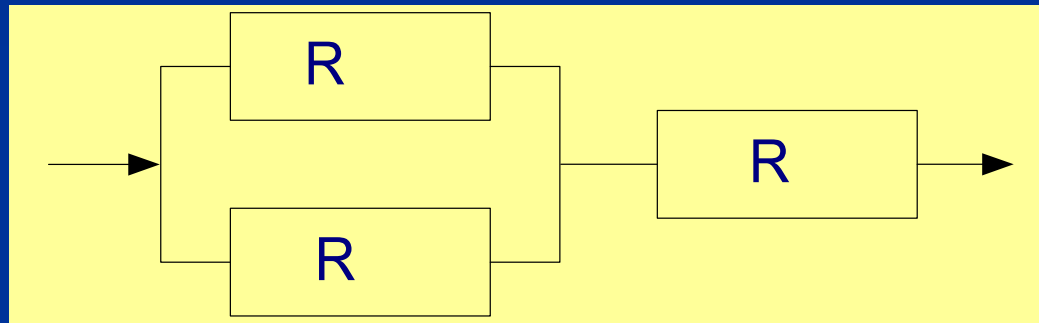

- Combining the series and parallel connections, the system reliability can be calculated as

$$R_{sys} = [1 - (1 - R_{Grid}) \cdot (1 - R_{FC})] \cdot R_{Tr}$$

Proposed Micro-Grid System Reliability Model

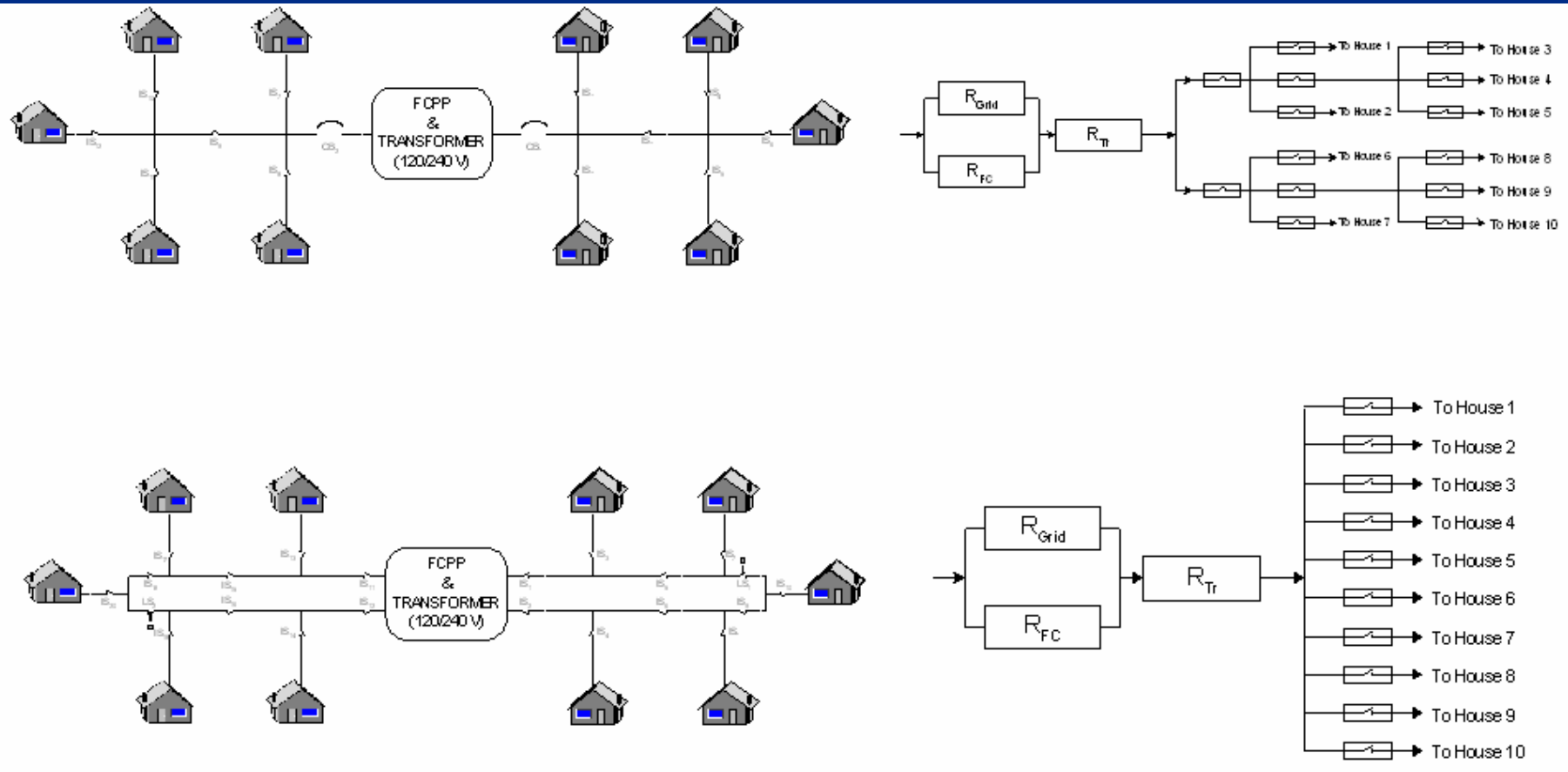

Reliability Analysis of Fuel Cell Power Plant

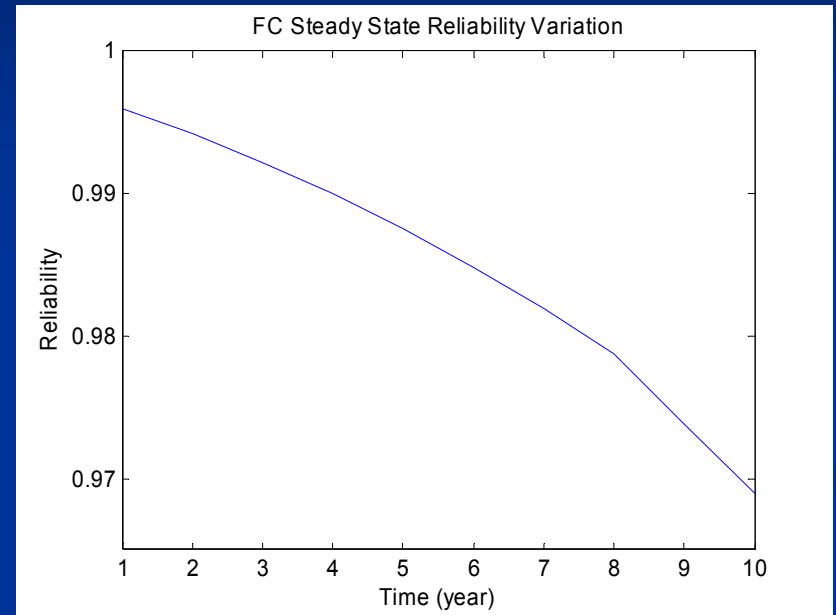
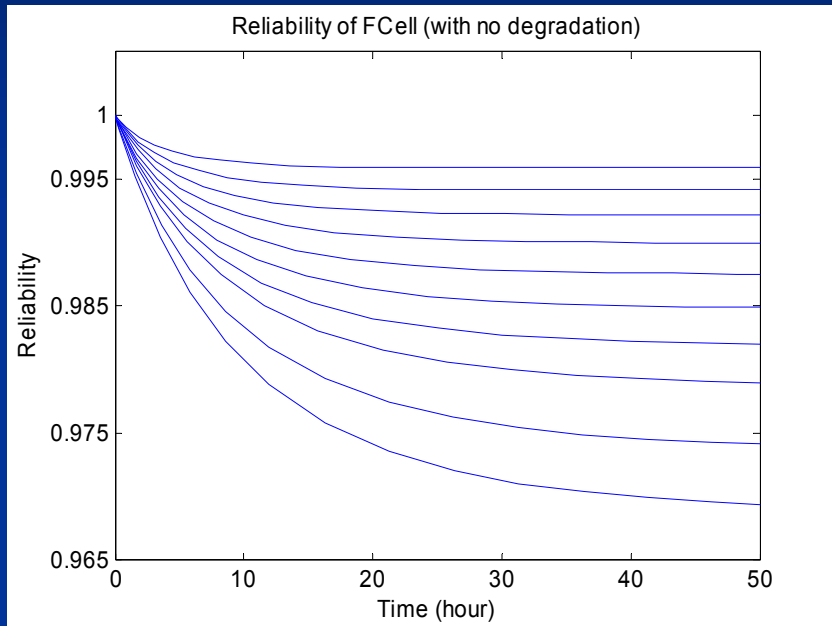

Reliability variation of FC, (a) instantaneous FC reliability for 1,2, ... , 10 years (from upper to lower lines respectively) (b) reliability variation of the FC versus year.

Energy Management Algorithms

- Implemented microgrid simulation in SEMaC software
 - Allows different Load Profiles to be simulated in rapid succession
 - Models typical occupancies in US Homes
- Implemented Historical Load Profile Database
 - Allows historical analysis and predictive algorithms
- Implemented Fuzzy Logic Management Algorithm
 - Prevents “Tail Chasing” at management thresholds

Power Control At The Appliance Level

Objective

To control power consumption at the appliance level resulting in total power management in a house.

Approach

- Range is chosen as the appliance.
- Four top heating elements, and two oven heating elements to control individually.
- Power level delivered to each element is controlled between 0% and 100% in a continuous manner using phase control method.

Accomplishments/Progress

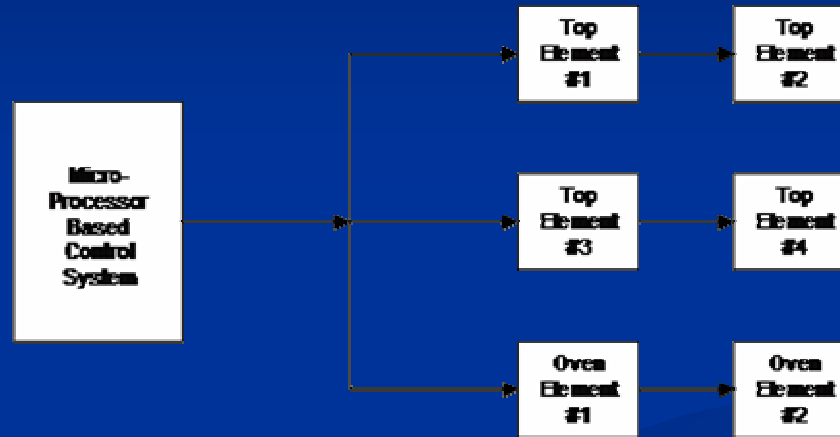

Block diagram of the range power control system

Accomplishments / Progress

- A high-power phase control device will be used to regulate amount of current delivered to each element.
- Each device is controlled on its low-voltage side through the microprocessor-based control system.
- The microprocessor-based control system will receive input requests from the user to adjust power delivered to any element, and will instruct the corresponding phase control device to deliver the requested power level.

Accomplishments/Progress

- Power level information for all elements will be communicated to the PC running LEMSYS (Local Energy Management SYStem) through an Ethernet link.
- LEMSYS may decide to keep the current power consumption, or may decide to reduce it.
- If it decides to reduce power delivered to a particular element, it will communicate a command to the microprocessor-based control system to do so.
- The microprocessor-based control system will execute that command, and report adjusted power level information back to LEMSYS.

Publications

- M. Y. El-Sharkh, A. Rahman, M. S. Alam, A. A. Sakla, P. C. Byrne and T. Thomas, “Analysis of Active and Reactive Power Control of a Stand-alone PEM Fuel Cell Power Plant,” *IEEE Transactions on Power Systems*, vol. 19, no.4, pp. 2022-2028, November 2004.
- P. C. Byrne, A. Rahman, A. A. Sakla, M. S. Alam, T. G. Thomas, M. Y. El-shark and K. Avadhanam, “Proton Exchange Membrane (PEM) Fuel Cell Steady-State Model for Residential Use,” under review.
- M. Y. El-Sharkh, A. Rahman, M. S. Alam, P. C. Byrne, A. A. Sakla, and T. Thomas, “A dynamic model for a stand-alone PEM fuel cell power plant for residential applications,” *Journal of Power Sources*, 138(2004), 199-204.