



Chapter 5

Hydrogen Battery Technology for Portable Applications

Richard Mohring, Millennium Cell, Inc.

Millennium Cell
The Hydrogen Battery Technology Company

Hydrogen Battery Technology for Portable Applications

Small Fuel Cells for Portable Applications Conference 2006
Washington, D.C.
3-Apr-2006

Richard M. Mohring, Ph.D.
Director – Technology Development and Engineering

Millennium Cell Inc.
One Industrial Way West
Eatontown, NJ 07724
mohring@millenniumcell.com
732-542-4000

1

Figure 1. Title Slide

Good afternoon. I'd like to step through an outline of the talk that I'll give (Figure 1 & 2). First I'll start out with some background information about Millennium Cell as our company has gone through a number of changes in the past few years, just to give everyone an idea of our strategy and our target markets. And then I'll get to the heart of the talk, which is regarding what we call Hydrogen Battery technology.



Figure 2. Outline

That's our approach of coupling sodium borohydride fuel systems with PEM fuel cells, particularly something we call the Hydrogen on Demand reaction. Then I'll step into a little bit of what we are doing now, our solid borohydride fuel blends, primarily. I'll talk about why and how we're doing that in the technology implementation section. Finally, I'll touch on passive PEM fuel cells, which is an area that we're starting to work a little more closely with some companies in development of those types of systems.

We call ourselves at Millennium Cell the "Hydrogen Battery Technology Company" (**Figure 3**). We were formed in 1998, and went public in 2000 on the NASDAQ. We consider ourselves experts in chemical hydrides - that's our business. We're not explicitly on the fuel cell side of it at the moment; we work with a number of partners, as you'll see. We have a wealth of patents and intellectual property in the area of chemical hydrides and have spent, someone calculated, 165 man-years of time working on that. Our focus is really in the 500 watt application scale and lower, though; so that's why we're here at Small Fuel Cells.

Our target markets are basically broken into four areas into which we focus our hydrogen battery platforms: military, medical, industrial and consumer systems (**Figure 4**). A lot of our initial work is in the military sector as the barriers to entry are a little bit easier to clear. But we do have efforts in all of those markets right now. The system on the left is the Protonex system that Paul Osenar showed earlier. And the system on the right is a passive PEM fuel cell system that we're working on for laptop computers.



Who is Millennium Cell?



- **The Hydrogen Battery Technology Company**
 - ▶ Formed in 1998 and went public in 2000
 - ▶ Ticker symbol "MCEL", NASDAQ market
- Hydrogen storage and delivery system technologies
 - ▶ **Chemical hydride expertise**
 - ▶ Over 25 patents granted and 40 pending
 - ▶ > 165 man-years working on NaBH₄
- Focused on portable applications under 500 watts



1

Figure 3. Who is Millennium Cell?

Target Markets



Millennium Cell and our fuel cell partners are developing distinct hydrogen battery platforms

Active PEM FC	Passive PEM FC
	

Arrows from both units point to four target markets: Military, Medical, Industrial, and Consumer.

1

Figure 4. Target Markets

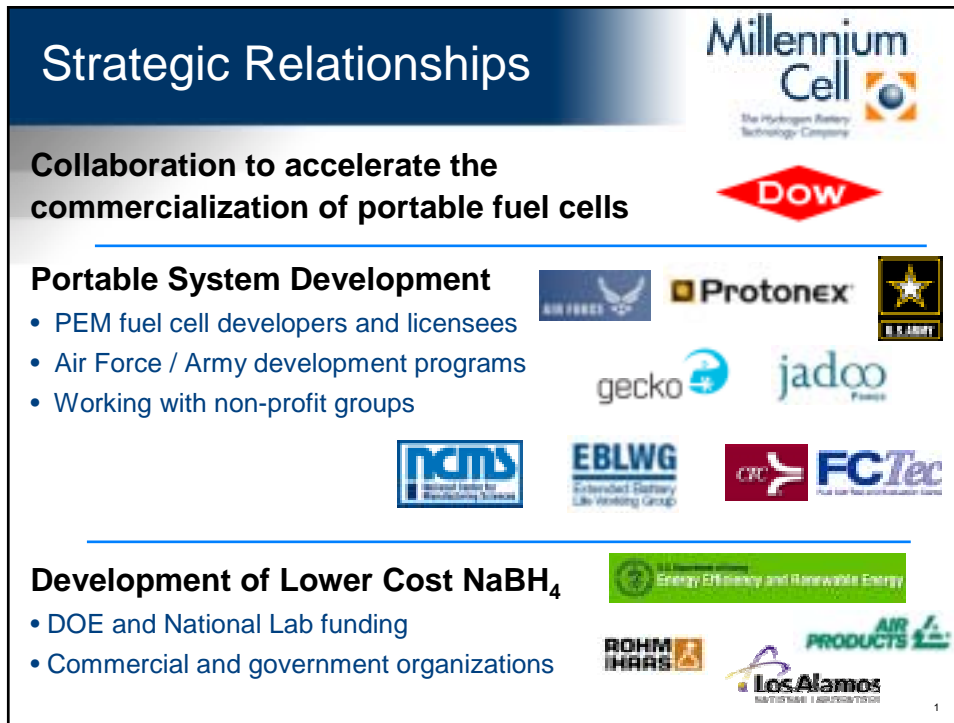

Figure 5. Strategic Relationships

We are an intellectual property company with a licensing business model, so relationships with other companies are very important to us (Figure 5). One of our biggest and most important relationships is a three year joint development agreement with the Dow Chemical Company. That relationship is structured to help us accelerate commercializing fuel cells out into the market.

Next, we have a number of relationships that are focused particularly on portable systems. In the top row, we are working jointly with the Air Force, the Army, and Protonex to develop the military power system that you saw earlier. We're also working with a company called Gecko Energy on passive PEM fuel cells. We've recently signed an agreement with Jadoo Power who is a PEM fuel cell company that has industrial products out in the market. On the other side, we're working with non-profit groups as well. NCMS is the National Center for Manufacturing Sciences. We have a DOE sponsored grant working there to accelerate our understanding of how to make fuel cartridges on larger scales. The Extended Battery Life Working Group is an organization sponsored by Intel, which is examining how people would like to use fuel cells in a laptop type of applications. The Fuel Cell Test & Evaluation Center at CTC is a laboratory in Johnstown, Pennsylvania with whom we're doing some DOD work.

Finally, we have research efforts that are sponsored primarily by the DOE on development of lower cost sodium borohydride. For the smaller systems, the cost of the fuel is not as relevant a driver, but when you start talking about getting chemical hydrides into automotive scale systems, it does become a lot more important as the targets are ultimately set by gasoline prices. So we're working in conjunction with the DOE, Rohm & Haas, Air Products, and Los Alamos National Lab to bring in the chemistry such that the cost of the fuel goes down.

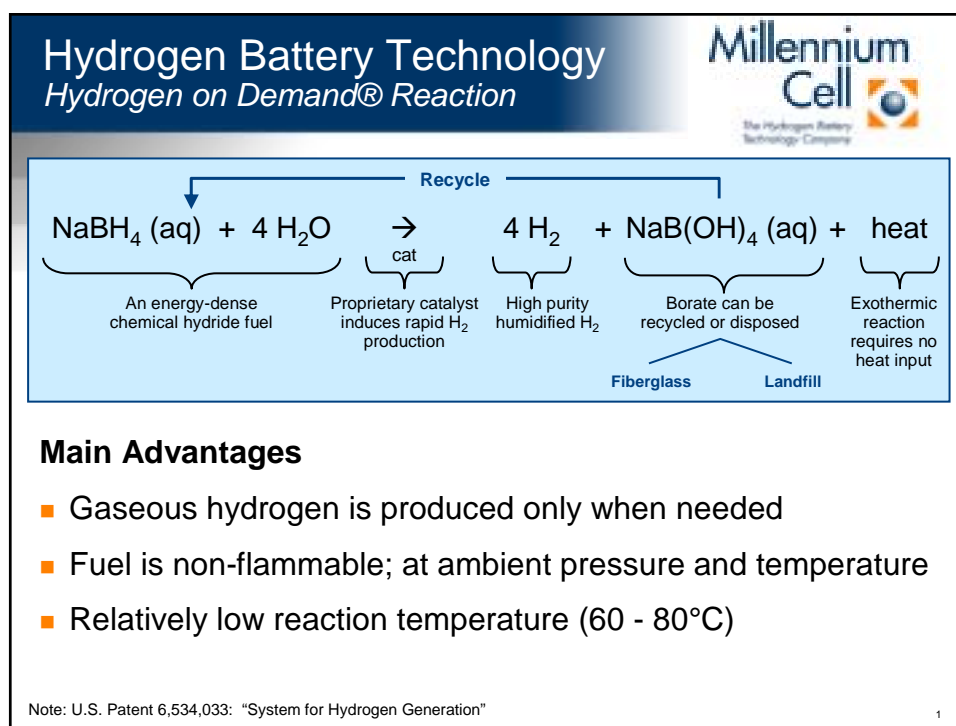

Figure 6. Hydrogen Battery Technology

The technology that we're talking about concerns the hydrolysis of sodium borohydride (**Figure 6**). It's a catalyzed hydrolysis process. The borohydride is combined with water and is reacted over a catalyst that we've developed to generate pure hydrogen and sodium metaborate - the $\text{NaB}(\text{OH})_4$ object on the right. A primary feature of this, and why we call it "Hydrogen on Demand®", is that you can control the hydrogen generation as you need it by pumping fuel over this catalyst, or by stopping the pumping of the fuel. The fuel itself is non-flammable. It's stored at ambient pressure and temperature, so it's an easy substance to deal with. And the reaction that generates the hydrogen is low temperature, 60-80°C, which is compared to in the 200-300°C range for methanol reformer technology, for example.

For the bulk of the talk I'll focus on solid borohydride fuel systems, and our motivation for focusing a lot of energy there (**Figure 7**). Liquid sodium borohydride fuels, in the aqueous form, are very energy dense. They do exhibit a slow self-discharge, however, and as you can see on the graph on the right, over the course of about a month the strength of the fuel decays by about 5%. So for long term storage say on shelf in a warehouse that kind of degradation is not going to be acceptable by the time you get the product out in the market. But I'll explain how we work around that in a moment. Solid sodium borohydride fuels have zero self-discharge. They're actually very air-stable. You can let them sit out on the table. You don't have to worry about them losing any potency in that kind of an environment. They will essentially be completely inactive at that point. Very high energy density obviously, because they're solid, you're not carrying the water with you. And there's also an advantage we have regarding the shipping class, that these now with our formulations can be declared a Class 8 material, as was discussed in the regulatory talk this morning.

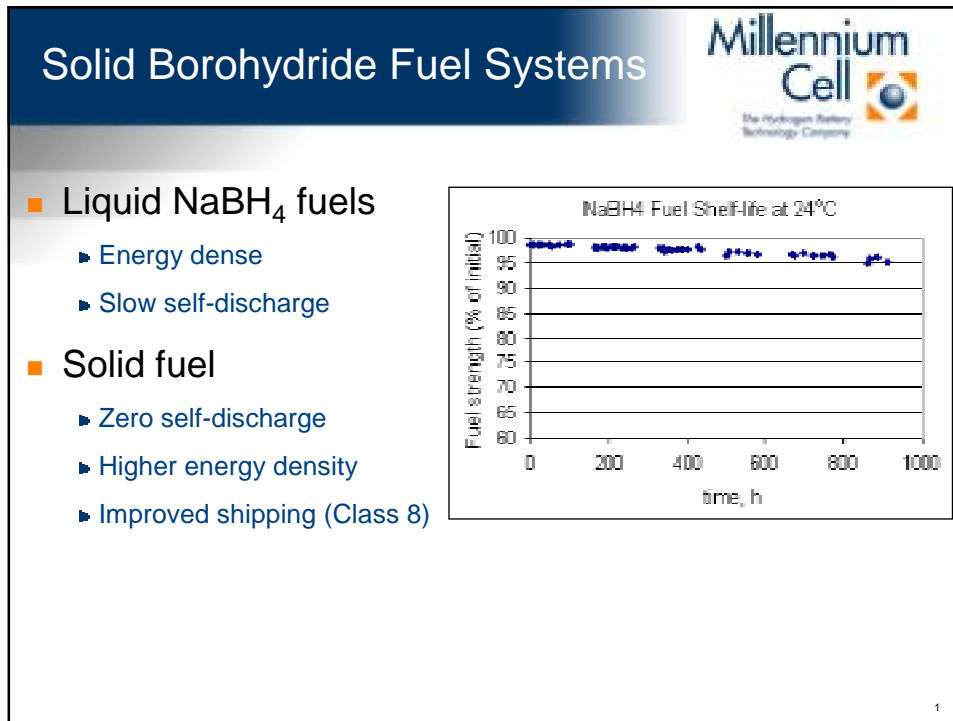

Figure 7. Solid Borohydride Fuel Systems

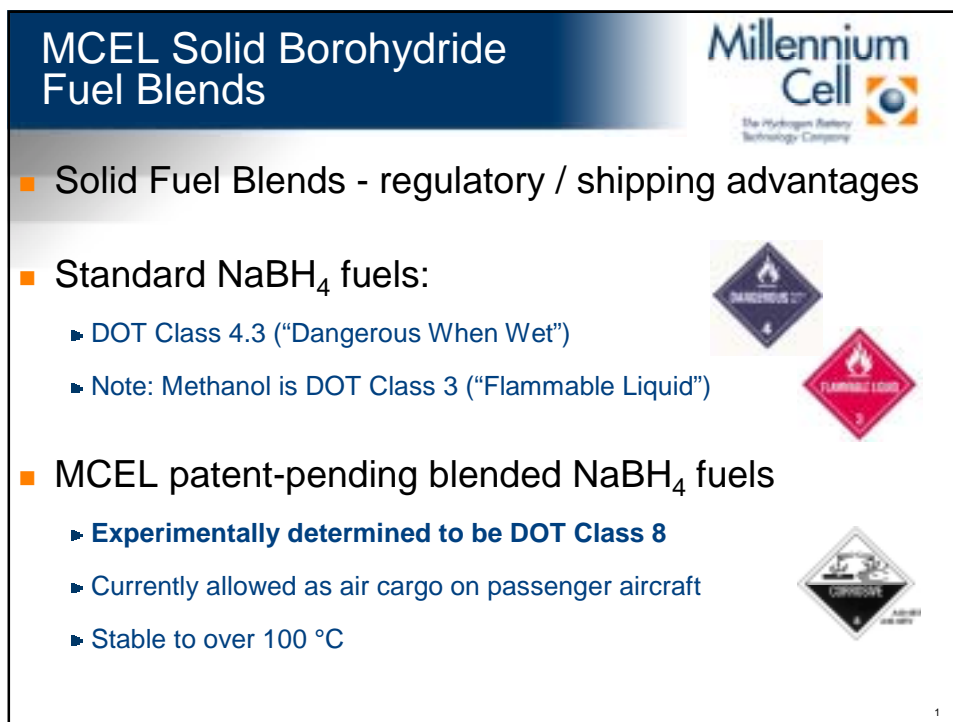

Figure 8. MCEL Solid Borohydride Fuel Blends



Our solid fuels have regulatory and shipping advantages (**Figure 8**). Standard sodium borohydride fuels are classified as something called “DOT Class 4.3”. They’re termed “dangerous when wet materials”. Simply put, if you add water to them they generate hydrogen rapidly enough that you can’t ship them without putting a “4.3” label on it. Based on the earlier talk, for example, the SiGNa material also would likely fall into that category. Methanol is, just for reference, DOT Class 3 because it’s a flammable liquid. For our part, we’ve spent a lot of time working to blend a stabilizing agent in with the fuel so as to avoid having a Class 4.3 classification. We have patents pending on a material that we’ve experimentally determined would be a Class 8 corrosive material. These materials are currently allowed as air cargo on passenger aircraft, which is a distinct advantage. These materials themselves are also stable to high temperatures.

Approaches to Solid Borohydride Fuel Systems

Millennium Cell
The Hydrogen Battery Technology Company

- Fixed-bed Catalysis HOD Technology
 - ▶ Solid and water kept separately
 - ▶ User activation
 - ▶ Field mixing
- Liquid Catalyzed HOD Technology
 - ▶ Solid and liquid reagent kept separately
 - ▶ Real-time addition of liquid reagent to solid fuel

1

Figure 9. Approaches to Solid Borohydride Fuel Systems

There are two approaches that I’ll discuss in the talk for how to get the hydrogen out of the sodium borohydride (**Figure 9**). First, what we call fixed bed catalysis HOD, Hydrogen on Demand® technology. That’s the same approach that you saw earlier in Paul Osenar’s talk, where the solid fuel and the water are kept separately. The user, in one way or another, brings the fuel and the water together and mixes them to make an aqueous solution. These systems are typically used within a month or so of them being activated. So the fact that you have this small loss in hydrogen isn’t as big of a deal for those systems.

For systems that need longer shelf stability, we’ve developed something we call liquid catalyzed HOD technology. In these systems, the solid and liquid reagent are kept separately within the same fuel cartridge. We do a real time addition of liquid reagent to the solid fuel to generate the hydrogen.

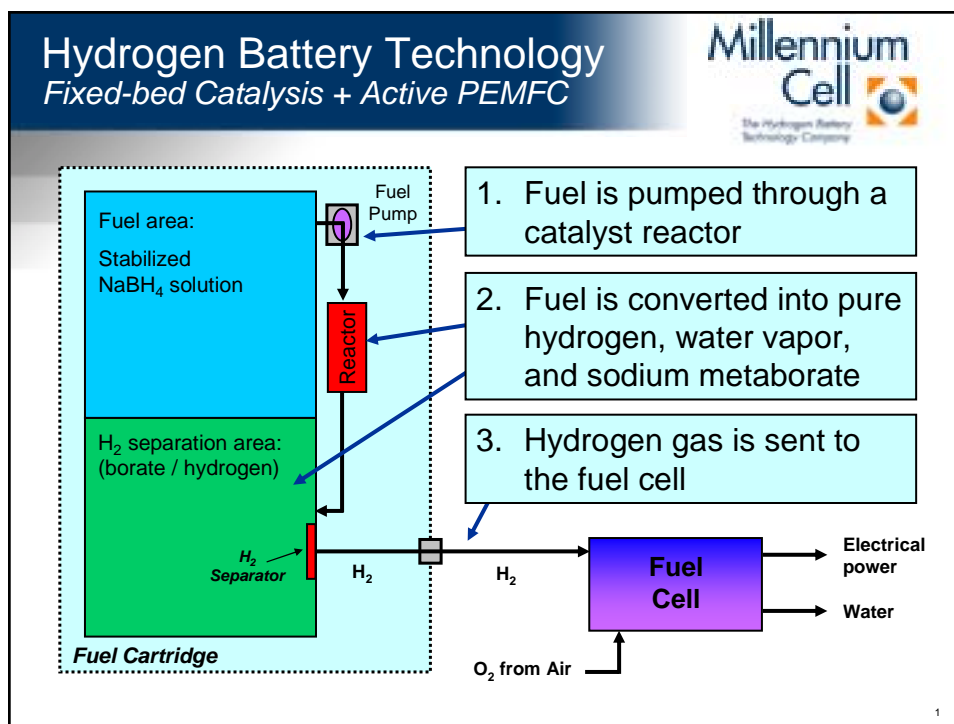

Figure 10. Hydrogen Battery Technology

I'll now talk a little bit about the fixed-bed catalysis approach first (**Figure 10**). Typically, as you can see on the top left, we have a cartridge that has an area that contains liquid fuel – a stabilized sodium borohydride solution. There's a fuel pump that pumps that fuel through a catalyst reactor, which is also located on the cartridge. As it passes through the catalyst reactor, the fuel is converted into hydrogen, water vapor and sodium metaborate. It's an exothermic reaction, so it doesn't require any additional energy to be put into it. Those materials will collect in a hydrogen separation area, shown as the green area at the bottom on this slide. Hydrogen then will pass out of that area through a separator membrane to be delivered to the fuel cell. Now typically when we make one of these systems it will start out such that the entire cartridge is “blue”, that is, it would be entirely filled with fuel. Over the course of operation, the green area will fill up, so that we exchange the volume that was initially held up by fuel with where the borate goes. There's no reason to put it in two separate canisters. That allows us to get much higher volumetric energy densities.

One of the things that we pride ourselves on, and a lot of this comes out of our experience with the Air Force contracts with Protonex, is our ability to integrate these systems tightly with a PEM fuel cell, particularly an active PEM fuel cell (**Figure 11**). Three aspects of that that I'd just like to touch on here: first of all, capturing the fuel cell water. The PEM fuel cell, in addition to putting out electricity and heat, is also putting out some amount of water. For our system, we can take that water and recirculate it back into the fuel cartridge to be used for energy generation, or at a minimum we can at least store it in the fuel cartridge so it's not output from the system, all over the warfighter. Better than that, though, is that we can store a high concentration of sodium borohydride solution in the cartridge in the first place, and dilute that with the captured fuel cell water in a real time to a concentration that's processable by the reactor. Those concentrations are in the range of 20-30 wt% borohydride.

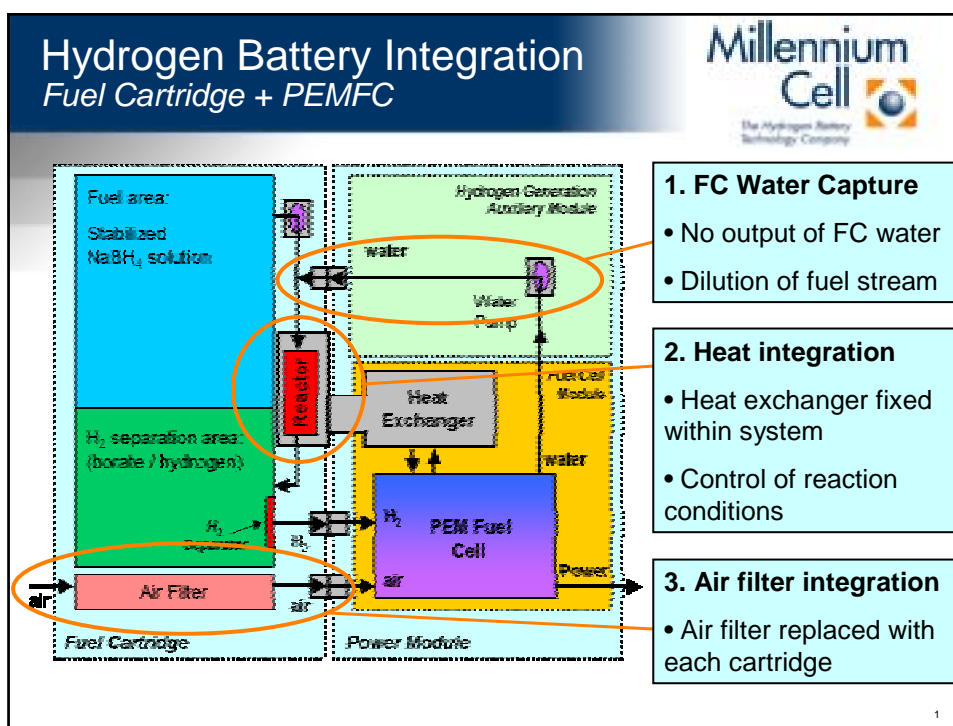

Figure 11. Hydrogen Battery Integration

Second, heat integration. There's a heat exchanger that's fixed within the active PEM fuel cell. We bring that into intimate contact with the catalyst reactor in the cartridge. That allows us to control the reaction conditions, to optimize the efficiency of the system, depending on the ambient conditions. It also allows us to not have any of the expensive components that are associated with heat exchangers on board the cartridge. Instead, we have a small, metallic heat fin that's sitting on the cartridge. I should also point out that the reactor itself for these systems does carry the catalyst within it, and we expect it to be disposable. There is on the order of about a dime's worth of active material in the catalyst chamber.

Last, and Paul touched on this, an air filter is integrated into the cartridge. This helps protect the fuel cell's long term operation by filtering out volatile organics, for example. That way you can throw it out with every cartridge; you don't need to have a larger scale filter in the system.

As I said, Millennium Cell is primarily an intellectual property development company, but we do quite a bit of prototyping to develop our intellectual property (**Figure 12**). Without actually doing a lot of the technical work, we wouldn't have things to patent. One particular apparatus that we've set up is a 24/7 four system operation bench. We'll typically run cartridges on flow controllers to simulate fuel cells, we can fairly accurately model the load profiles that you'd see from actual fuel cells. This allows my team to do very rapid testing of control algorithms, cartridge design, and components. For example, I mentioned that there's a flexible barrier within the cartridge that allows the fuel and the byproduct to exchange space. In designing that system, we made a number of revisions to that structure and we were able to test options very quickly over long term testing here. We've put about 1500 hours of testing on this bench already.

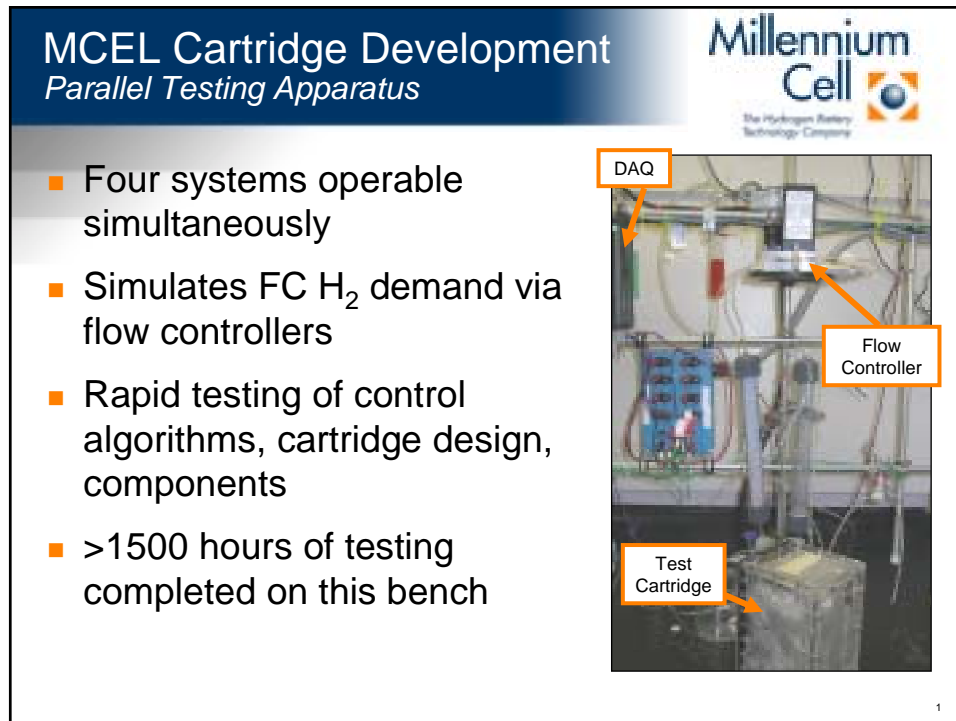

Figure 12. MCEL Cartridge Development

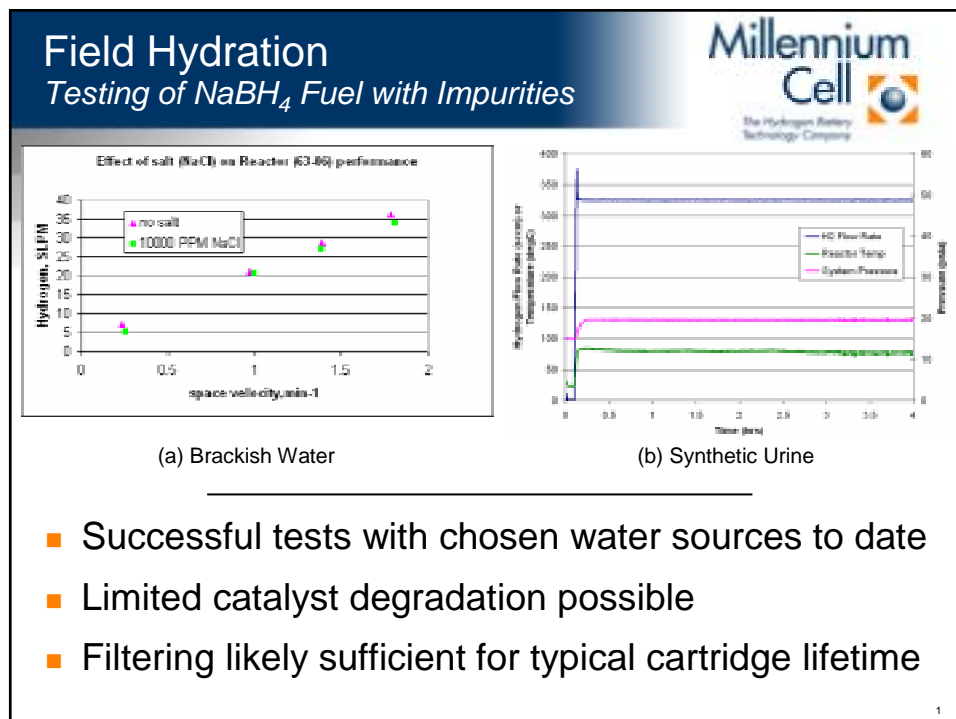

Figure 13. Field Hydration



The kind of data that we take on that bench is represented on the next slide (**Figure 13**). As I said, the idea of using solid sodium borohydride in a catalyzed system requires the user to mix the solid sodium borohydride with water at the time of use to make a fuel solution. Now that gives us a lot of advantage in terms of weight of shipment, because you're not shipping the water around. But then the question on the other side of it is what kind of water do you need to actually make the fuel? If you get there and you need Perrier to make the fuel, you really haven't saved yourself very much. So we've looked at impure waters in our studies here. The first one is salt water, technically "brackish water", which has a salinity between sea water and fresh water. You can see in this graph, on the horizontal axis is a measure of how fast we're pushing the gas pedal on the reactor.

So as you move to the right on this axis, we're pushing the catalyst chamber harder and harder, trying to get more hydrogen out of a given reactor volume. The vertical axis is showing you how much hydrogen is coming off as you vary that. We expect this to essentially be a linear relationship, that if you double the amount of fuel that you push through the chamber, you get twice as much hydrogen. And you can see in this graph two sets of curves, one is done with a pure DI water fuel, and the other one is done with fuel made with a one percent sodium chloride solution. We don't see any difference between those two fuels.

But that's not nearly as hard to deal with as another fuel which is, to use my earlier analogy, quite the opposite of Perrier. For the soldier applications, one of the things that's really most attractive is if they can use things like bodily fluids to make fuel. You can imagine a special operations force would really find this to be a very important addition to their arsenal if they're out somewhere without a lot of options. So believe it or not, you can actually purchase synthetic urine to do these experiments. This is a product that is intended to be used for calibrating drug testing equipment. We have a new market for them - testing Hydrogen on Demand® generators.

What you can see in this graph is "boring" data. In our context, boring data is good data because you have flat lines, and it shows that nothing funny is happening. The top line on the graph is the hydrogen flow rate that we're generating with the cartridge made with fuel made from synthetic urine. It is operating at about the right rate to be generating 30 watts net power. So you can see that operates just fine. It also shows you the reactor temperature and system pressure on the other two curves, completely consistent with what we would see with normal water. In addition to these tests, we've also done lake water from a local reservoir and we've also looked at synthetic hard water, which has more calcium salts for example.

We've had successful hydrogen generation with all those waters to date, although we do see in the systems that have the organic contaminants, like the urine and the lake water, the potential for a limited amount of catalyst degradation over the course of time.

One of the things that is nice about our approach though is that even if the catalyst does degrade, we're expecting to be throwing the catalyst bed out at the end of the cartridge life. So we feel based on our initial experiments that simple filtering would take enough impurity out of the water such that you can make it through a cartridge lifetime.

Additionally you can make the catalyst a little bit larger, for example, to extend the lifetime of the reactor. So, in summary, this is the approach that we've taken on standard catalyzed HOD technology.

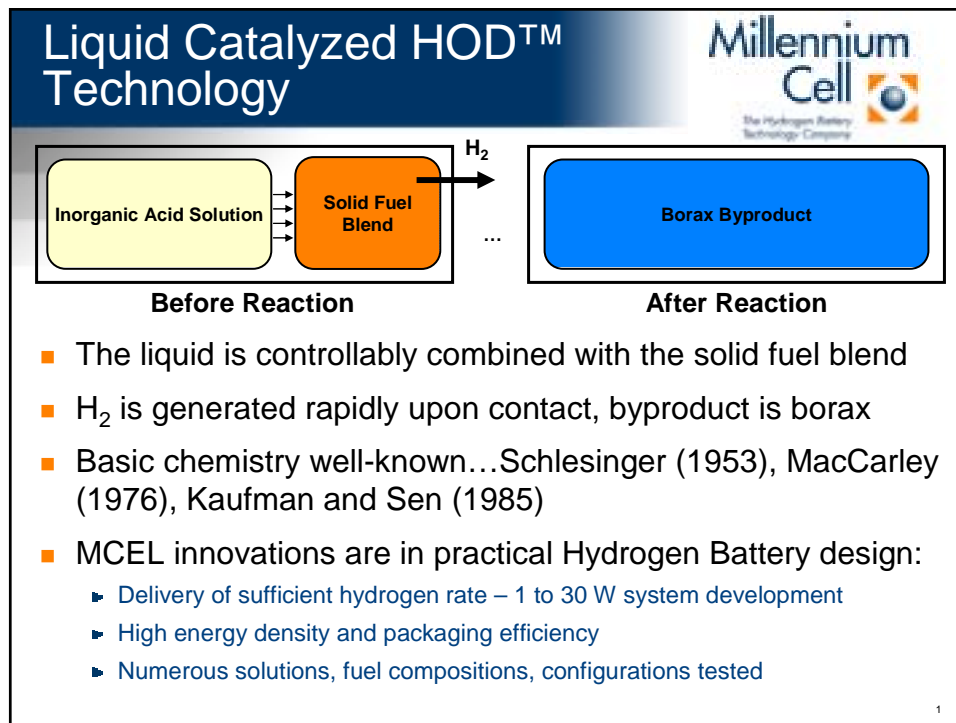

Figure 14. Liquid Catalyzed HOD™ Technology

The other approach I'd like to discuss is what we call "liquid catalyzed HOD technology", where the liquid, in this case an inorganic acid solution, is controllably combined with a solid fuel blend that's in a cartridge (Figure 14). It generates hydrogen very rapidly and the byproduct is borax. The basic chemistry of this is very well known since at least 1953 - one of the earliest references I can find on that. What we at Millennium Cell bring to the table there, though, are innovations on making these practical systems. We've spent a lot of time on this over the past five years, driving to achieve sufficient hydrogen rates at high conversion and packaging these systems.

Some of the features: these systems give you zero loss in the hydrogen capacity, as it's a solid fuel stored with a reagent (Figure 15). They also exhibit a very rapid startup. We see fuel-only energy densities on these materials on the order of 1800 to 2200 Wh/kg on a lower heating value basis of the fuel itself. You can also see that 2400 Wh/L is the top end of the estimated volumetric energy density as well. We do have a platform in development right now that we target as exceeding 600 Wh/kg for the 72 hour, 30 watt mission. We also expect this approach to preserve our Class 8 hazard category that we've been working on.

On this data graph, the line with the bump in the middle is our hydrogen flow rate (Figure 16). You can see that this system is capable of generating variable rates of hydrogen, around about a 15 watt equivalent for a fuel cell. Hydrogen temperatures and reactor wall temperatures are cool in this system, so you can see they're in the 20 to 30°C range. The system is generating hydrogen for the fuel cell at essentially ambient pressure.

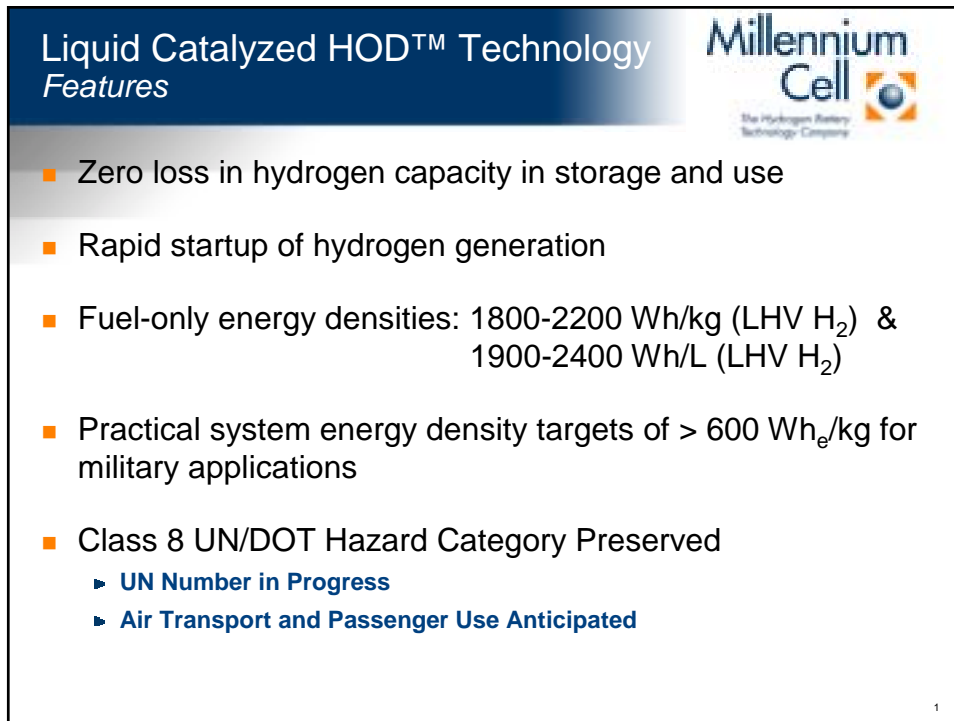

Figure 15. Liquid Catalyzed HOD™ Technology

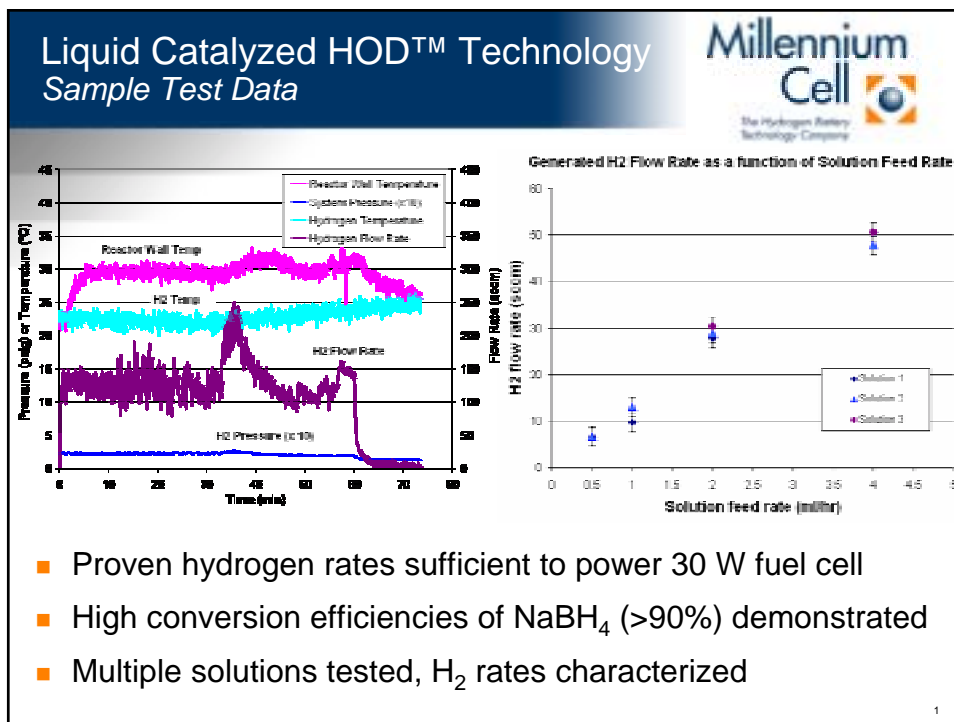



Figure 16. Liquid Catalyzed HOD™ Technology



Some of the testing that we've done is looking at how different reagent solutions function as you increase the rate at which you feed the solution to the solid. One detail we'd like to measure is where the generation rate turns over and you start to overwhelm the system with too much solution. You can see in the graph that we've pushed it up over some limit and can say where you don't want to be operating, on the top right hand of that graph. In that condition, you're wasting some of your reagent because you're not getting as much hydrogen out of it as you would like to. So we've optimized those systems quite a bit. In our experiments we've proven that we can generate 30 watts this way. We have consistently demonstrated over 90% conversion of borohydride into hydrogen.

Passive PEM Fuel Cells



- MCEL partnering with PEMFC companies to develop low power passive systems
- Target applications < 20 W
- Advantages of passive PEM
 - ▶ High power density → fits in device
 - ▶ High efficiency → lower waste heat
 - ▶ Simple architecture with minimal BOP
 - ▶ Low cost → \$1 to \$5 per watt
 - ▶ Thin, flat form factor → no lumps

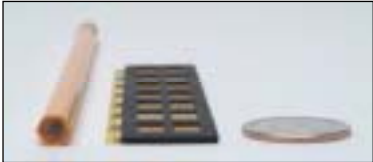

1

Figure 17. Passive PEM Fuel Cells

On the last two content slides, I'd like to give an update on passive PEM fuel cells for these types of systems (**Figure 17**). We've been partnering with PEM fuel cell companies to look at low power passive systems, typically targeted at sub-20 watt applications, mainly because of heat dissipation issues with those cells. We want to start there and then we'll work on getting more power out of them later. Some advantages are: They're very high power density devices. They operate at high efficiency; they don't have a lot of waste heat, particularly in comparison to other types of fuel cell technologies. They have a very simple, straightforward architecture so there's not a lot of balance of plant involved. And we do expect them to be low cost, on the order of one to five dollars per watt.

The thin form factor allows us put these fuel cells into a system as shown here, where it would be implemented on the back of a screen of a laptop (**Figure 18**). Some of the work we did with the Extended Battery Life Working Group shows that users typically prefer an integrated fuel cell approach for a laptop, rather than an independent charger box that's sitting next to it. We feel that the planar PEM technology could be located on the back of the screen, which is an advantage over, for example, DMFC systems. DMFC power levels have tended to be lower when they've been integrated into systems.



Passive PEM Fuel Cells

Laptop PC Application



- EBLWG → Users prefer integrated FC vs. independent charger
- Planar PEM technology → fuel cell on back of screen
- Low power density of DMFC → difficult to integrate
- High energy density of HOD + PEMFC → fully integrated solution

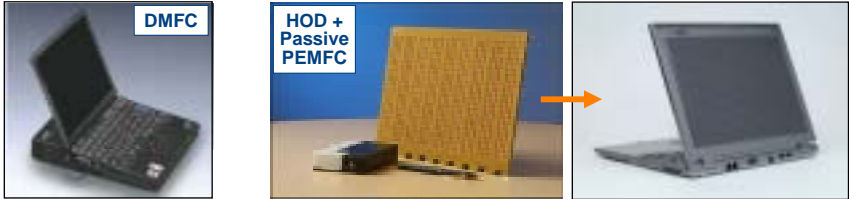

- ▶ Architecture demonstration system (2005) → 3.3 hr @ 10 W
- ▶ Integrated prototype development (2006-07) → 6 - 9 hr
- ▶ Alpha Product (2007-08) → 12 - 18 hr

1

Figure 18. Passive PEM Fuel Cells

Summary



- Millennium Cell is developing Hydrogen Battery technology
 - ▶ Sodium borohydride (NaBH_4) expertise
 - ▶ Solid NaBH_4 fuel blends
 - ▶ Successfully demonstrated in multiple applications
- Benefits of NaBH_4 systems:
 - ▶ High energy density
 - ▶ Long shelf-life
 - ▶ Hydrate cartridges at point of use
 - ▶ Regulatory and logistics chain advantages

Thank you!

1

Figure 19. Summary



We expect that the higher energy density of the chemical hydride, combined with the flat panel fuel cell, should allow for a fully integrated solution that would be something that people would be interested in buying. We performed a technology demonstration last year, and are working on a new system that would be a six to nine hour cartridge that would operate the laptop. Ultimately, we're looking at an alpha product in the 2007-08 area, somewhere in the 12 to 18 hour run time.

So in summary, at Millennium Cell we're developing what we call "Hydrogen Battery Technology" (**Figure 19**). We see ourselves as being experts in sodium borohydride. We've done a lot of work on solid sodium borohydride fuel blends for the reasons that I talked about earlier. We've demonstrated our technology in a number of applications and have prototype systems in the hands of customers. Benefits of the systems are: high energy density. When you're working a solid form, you have very long shelf life of the fuel. Finally, the ability to hydrate the cartridges at the point of use is an advantage from the logistics chain and the regulatory standpoint. Thank you. I'll take any questions.

Question & Answer:

Audience Member: What applications do you see for the acid based system that you described, the second one?

RM: We're starting out looking at the military, the same kind of military applications to begin with, primarily because we understand the targets for those applications very well and we see being able to do research and development on those kinds of contracts. But that type of system has promise for the high energy densities that we see being needed for sensor applications, for example, on a small scale or potentially this laptop application.

Audience Member: You're describing the applications that my company does, so let me follow up a little bit. How do you distinguish the applications that the acid based would meet better than the first source of fuel?

RM: Primarily because the first approach requires a user activation of some sort. So there are certain applications where we at least anticipate that it would be less attractive for someone to activate a cartridge before it goes into a system. Now that's our anticipation – I wouldn't say that we have hard market data that shows that we shouldn't try that approach. But I think for systems that we expect to need to be shelf stable and operable for very long periods of time, for example, a sensor that's going to operate for a year in a situation, we'd see the acid approach being more relevant.

Audience Member: So what you're describing, then, are automated or autonomous systems, or ones that need a long shelf life, or a long functional period.

RM: That's correct.

Audience Member: Could you comment on the status for recycle, what efficiencies you can get, recycle the oxide?

RM: You mean overall well to wheel efficiencies and things like that? I'd first start with "that's not my department", but that's not quite fair. That said, I would be remiss to try to throw efficiencies out off the top of my head because it technically isn't my focus area. I'd be happy to talk with you about



that later, but certainly in the DOE programs that we talked about, one of the main drivers is the energy efficiency of the processes. We have been focusing on an electrolytic process for regenerating sodium borohydride from the borate materials. We see that the efficiency of that process is a lot higher than the current processes that exist out there. So we do think there's significant promise. But if you want to know the actual numbers on the well to wheel, we should probably wait until I look it up.

Audience Member: On the synthetic urine chart, it looked like it took about a tenth of an hour, or let's say 6 minutes, for the hydrogen pressure to finally develop. And my question was, is that what's happening there? So it looks like it takes some time for the hydrogen pressure to develop and how is this affected with temperature, especially low temperature.

RM: That's a good question; I didn't actually mention this. The startup time of these systems is typically on the order of 30 seconds or less. Actually what you can see here, the delay is just that the data acquisition system was running a little bit earlier than when we started the pump. We're operating them at room temperature and it gets progressively faster as you're a little warmer. When we're at -20°C or so, we expect that the startup time is going to be on the order of minutes at that stage, from its own heat. It really comes down to a question of how you design the reactor and the thermal mass in the system. If there's a lot of metal around, for example, it takes longer because it has to heat up the environment as well. But the reaction itself, the catalysts for these systems are very active. As part of our research program with the Army right now, one of the things we're looking at is how the cold start behavior is. We haven't quantified it yet. We've done qualitative tests to show that the reaction starts up at those low temperatures, but the anticipation is it's still going to be less than minutes, plenty of time for the hybridization battery in these systems to ride out.

Audience Member: And a follow on question, with the heat exchanger, what kind of temperatures are we talking, in terms of what the user might see?

RM: The heat exchanger normally operates at around 60°C or so.

Audience Member: Even at high temperature? Because your ambient, in a vehicle, could approach 60°C.

RM: I guess I don't understand, what was your question again?

Audience Member: When you said it could be 60°C, that's if you're running at ambient.

RM: Sure, it's anywhere from 60 to 80°C. We're currently doing testing on the high temperature side on the environmental chamber where we're operating at 50°C and higher. So the heat exchanger can get up into the 80° area at that point, but it has enough fan power to keep it there.

Audience Member: Cost of the chemical per kilowatt and the cost of the cartridge for a notebook?

RM: It's estimated to be on the order of \$5 or so for the cartridge. The chemical itself is, right now if you bought it at retail, anywhere from \$20 to \$40 a kilogram for that material. Now what that translates into is you're talking about a dollar or two worth of fuel in a cartridge of this scale.